

DATA MINING 2

Anomaly & Outliers Detection

Riccardo Guidotti

a.a. 2019/2020

Slides edited from Tan, Steinbach, Kumar, Introduction to Data Mining and from Kriegel, Kröger, Zimek Tutorial on Outlier Detection Techniques



What is an Outlier?

Definition of Hawkins [Hawkins 1980]:

- “An outlier is an observation which deviates so much from the other observations as to arouse suspicions that it was generated by a different mechanism”

Statistics-based intuition

- Normal data objects follow a “generating mechanism”, e.g. some given statistical process
- Abnormal objects deviate from this generating mechanism

Anomaly/Outlier Detection

- What are anomalies/outliers?
 - The set of data points that are considerably different than the remainder of the data
- Natural implication is that anomalies are relatively rare
 - One in a thousand occurs often if you have lots of data
 - Context is important, e.g., freezing temps in July
- Can be important or a nuisance
 - 10 foot tall 2 year old
 - Unusually high blood pressure

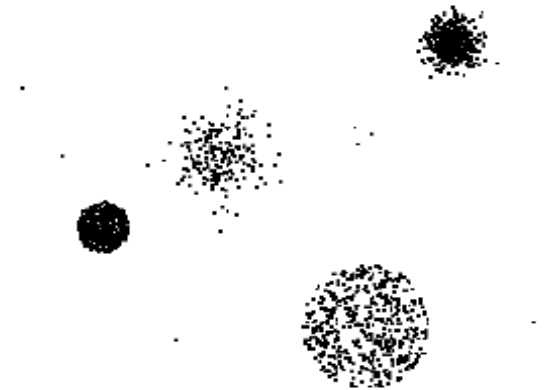

Applications of Outlier Detection

- Fraud detection
 - Purchasing behavior of a credit card owner usually changes when the card is stolen
 - Abnormal buying patterns can characterize credit card abuse
- Medicine
 - Unusual symptoms or test results may indicate potential health problems of a patient
 - Whether a particular test result is abnormal may depend on other characteristics of the patients (e.g. gender, age, ...)
- Public health
 - The occurrence of a particular disease, e.g. tetanus, scattered across various hospitals of a city indicate problems with the corresponding vaccination program in that city
 - Whether an occurrence is abnormal depends

Importance of Anomaly Detection

Ozone Depletion History

- In 1985 three researchers (Farman, Gardinar and Shanklin) were puzzled by data gathered by the British Antarctic Survey showing that ozone levels for Antarctica had dropped 10% below normal levels
- Why did the Nimbus 7 satellite, which had instruments aboard for recording ozone levels, not record similarly low ozone concentrations?
- The ozone concentrations recorded by the satellite were so low they were being treated as outliers by a computer program and discarded!

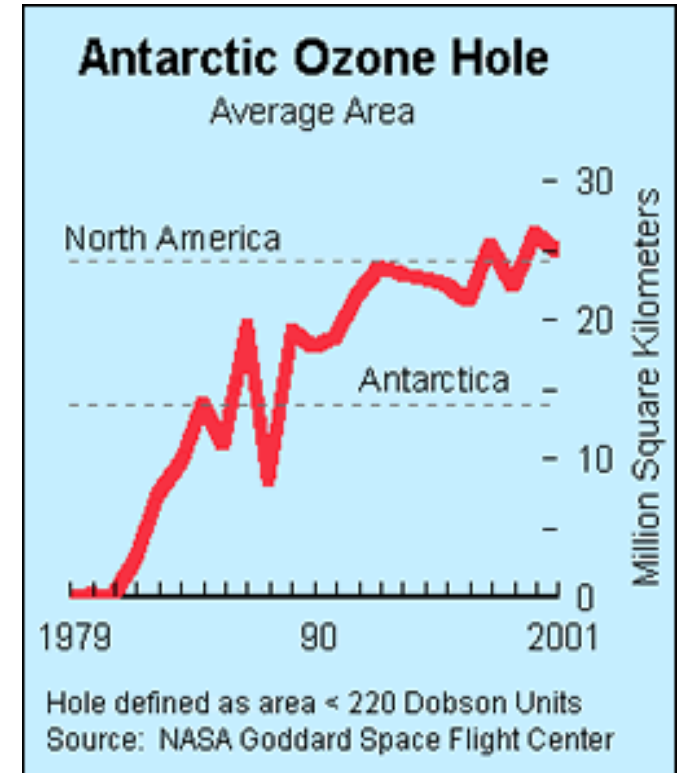

Causes of Anomalies

- Data from different classes
 - Measuring the weights of oranges, but a few grapefruit are mixed in
- Natural variation
 - Unusually tall people
- Data errors
 - 200 pound 2 year old

Distinction Between Noise and Anomalies

- Noise is erroneous, perhaps random, values or contaminating objects
 - Weight recorded incorrectly
 - Grapefruit mixed in with the oranges
- Noise doesn't necessarily produce unusual values or objects
- Noise is not interesting
- Anomalies may be interesting if they are not a result of noise
- Noise and anomalies are related but distinct concepts

General Issues: Number of Attributes

- Many anomalies are defined in terms of a single attribute
 - Height
 - Shape
 - Color
- Can be hard to find an anomaly using all attributes
 - Noisy or irrelevant attributes
 - Object is only anomalous with respect to some attributes
- However, an object may not be anomalous in any one attribute

General Issues: Anomaly Scoring

- Many anomaly detection techniques provide only a binary categorization
 - An object is an anomaly or it isn't
 - This is especially true of classification-based approaches
- Other approaches assign a score to all points
 - This score measures the degree to which an object is an anomaly
 - This allows objects to be ranked
- In the end, you often need a binary decision
 - Should this credit card transaction be flagged?
 - Still useful to have a score
- How many anomalies are there?

Other Issues for Anomaly Detection

- Find all anomalies at once or one at a time
 - Swamping
 - Masking
- Evaluation
 - How do you measure performance?
 - Supervised vs. unsupervised situations
- Efficiency
- Context
 - Professional basketball team

Variants of Anomaly Detection Problems

- Given a data set D , find all data points $\mathbf{x} \in D$ with anomaly scores greater than some threshold t
- Given a data set D , find all data points $\mathbf{x} \in D$ having the top- n largest anomaly scores
- Given a data set D , containing mostly normal (but unlabeled) data points, and a test point \mathbf{x} , compute the anomaly score of \mathbf{x} with respect to D

Model-Based Anomaly Detection

Build a model for the data and see

- Unsupervised
 - Anomalies are those points that don't fit well
 - Anomalies are those points that distort the model
 - Examples:
 - Statistical distribution
 - Clusters
 - Regression
 - Geometric
 - Graph
- Supervised
 - Anomalies are regarded as a rare class
 - Need to have training data

Machine Learning for Outlier Detection

- If the ground truth of anomalies is available we can prepare a classification problem to unveil outliers.
- As classifiers we can use all the available machine learning approaches: Ensembles, SVM, DNN.
- The problem is that the dataset would be very unbalanced
- Thus, ad-hoc formulations/implementation should be adopted.

Additional Anomaly Detection Techniques

- **Proximity-based**
 - Anomalies are points far away from other points
 - Can detect this graphically in some cases
- **Density-based**
 - Low density points are outliers
- **Pattern matching**
 - Create profiles or templates of atypical but important events or objects
 - Algorithms to detect these patterns are usually simple and efficient

Outliers Detection Approaches Classification

- **Global vs local** outlier detection
 - Considers the set of reference objects relative to which each point's "outlierness" is judged
- **Labeling vs scoring** outliers
 - Considers the output of an algorithm
- **Modeling properties**
 - Considers the concepts based on which "outlierness" is modeled

Global versus Local Approaches

- Considers the resolution of the reference set w.r.t. which the “outlierness” of a particular data object is determined
- **Global approaches**
 - The reference set contains all other data objects
 - Basic assumption: there is only one normal mechanism
 - Basic problem: other outliers are also in the reference set and may falsify the results
- **Local approaches**
 - The reference contains a (small) subset of data objects
 - No assumption on the number of normal mechanisms
 - Basic problem: how to choose a proper reference set
- Notes
 - Some approaches are somewhat in between
 - The resolution of the reference set is varied e.g. from only a single object (local) to the entire database (global) automatically or by a user-defined input parameter

Labeling versus Scoring

- Considers the output of an outlier detection algorithm
- **Labeling approaches**
 - Binary output
 - Data objects are labeled either as normal or outlier
- **Scoring approaches**
 - Continuous output
 - For each object an outlier score is computed (e.g. the probability for being an outlier)
 - Data objects can be sorted according to their scores
- **Notes**
 - Many scoring approaches focus on determining the top-n outliers (parameter n is usually given by the user)
 - Scoring approaches can usually also produce binary output if necessary (e.g. by defining a suitable threshold on the scoring values)

Model-based Approaches

Approaches classified by the properties of the underlying modeling

- Rational
 - Apply a model to represent normal data points
 - Outliers are points that do not fit to that model
- Sample approaches
 - Probabilistic tests based on statistical models
 - Depth-based approaches
 - Deviation-based approaches
 - Some subspace outlier detection approaches

Model-based Approaches

Proximity-based Approaches

- Rational
 - Examine the spatial proximity of each object in the data space
 - If the proximity of an object considerably deviates from the proximity of other objects it is considered an outlier
- Sample approaches
 - Distance-based approaches
 - Density-based approaches
 - Some subspace outlier detection approaches

Model-based Approaches

Angle-based approaches

- Rational
 - Examine the spectrum of pairwise angles between a given point and all other points
 - Outliers are points that have a spectrum featuring high fluctuation

Visual Approaches

- Boxplots or Scatter plots
- Limitations
 - Not automatic
 - Subjective

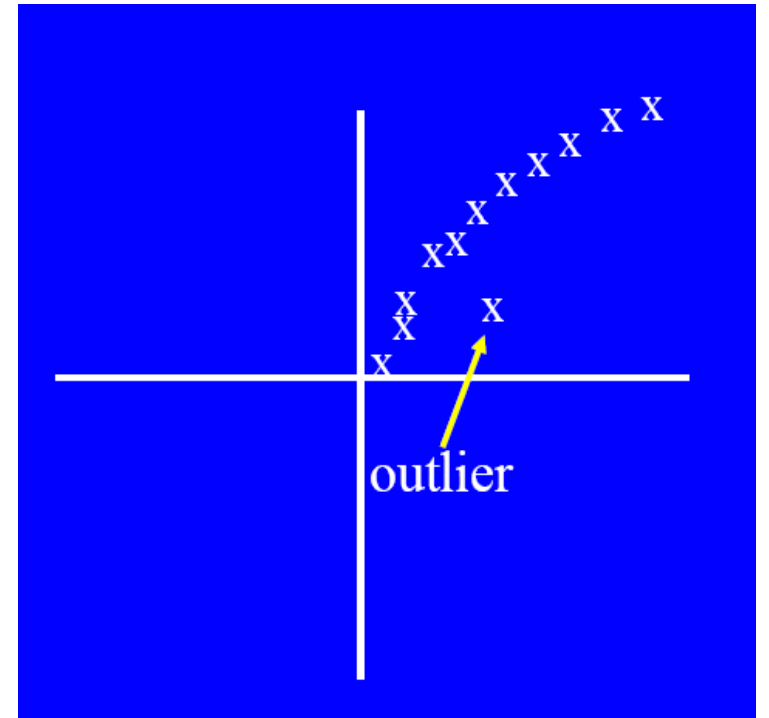
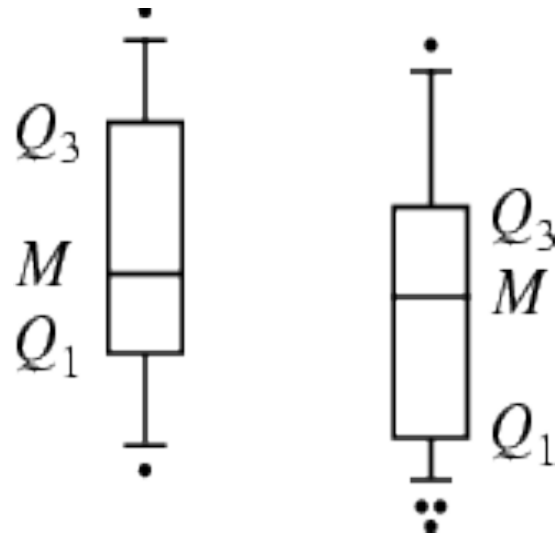

Statistical Approaches

Statistical Approaches

Probabilistic definition of an outlier: An outlier is an object that has a low probability with respect to a probability distribution model of the data.

- Usually assume a parametric model describing the distribution of the data (e.g., normal distribution)
- Apply a statistical test that depends on
 - Data distribution
 - Parameters of distribution (e.g., mean, variance)
 - Number of expected outliers (confidence limit)
- Issues
 - Identifying the distribution of a data set
 - Heavy tailed distribution
 - Number of attributes
 - Is the data a mixture of distributions?

Normal Distributions

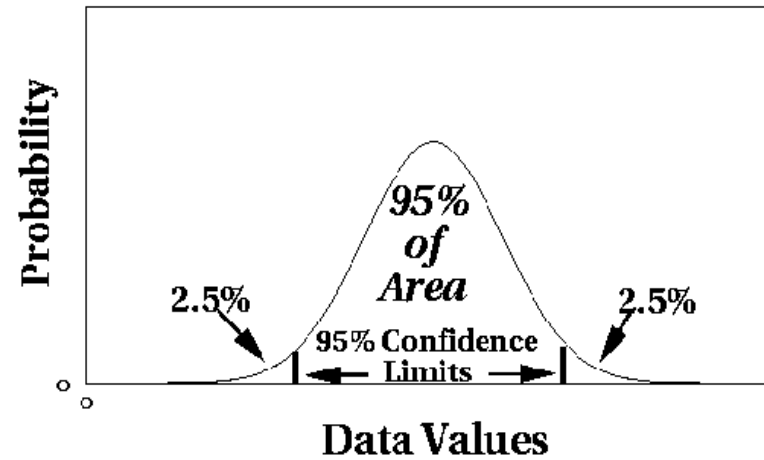

**One-dimensional
Gaussian**

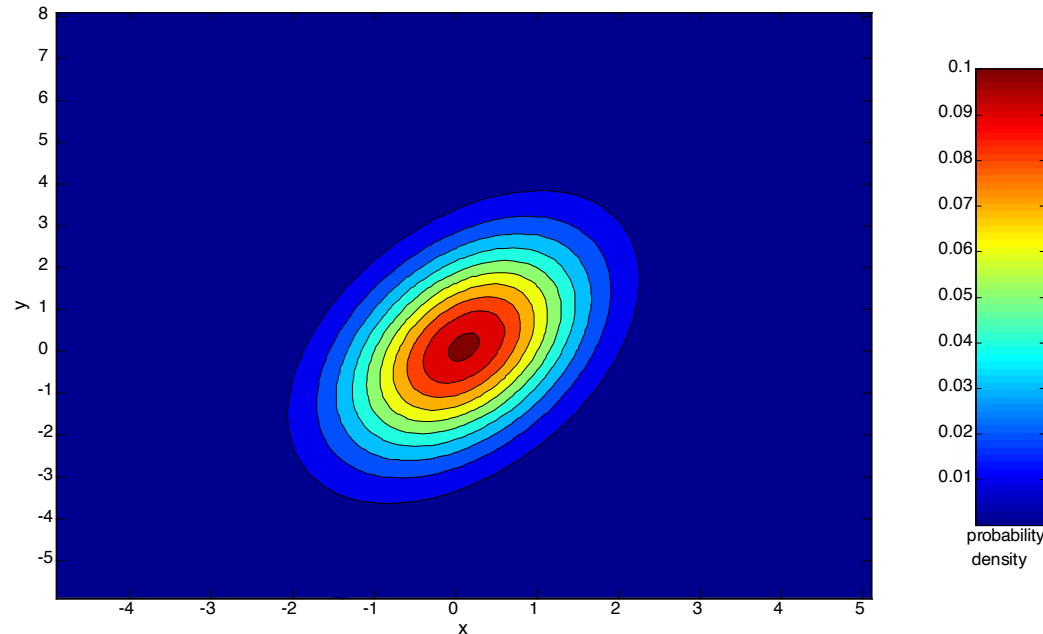

**Two-dimensional
Gaussian**

Statistical-based – Grubbs' Test

- Detect outliers in univariate data
- Assume data comes from normal distribution
- Detects one outlier at a time, remove the outlier, and repeat
 - H_0 : There is no outlier in data
 - H_A : There is at least one outlier

- Grubbs' test statistic:
$$G = \frac{\max |X - \bar{X}|}{s}$$

- Reject H_0 if:
$$G > \frac{(N-1)}{\sqrt{N}} \sqrt{\frac{t^2_{(\alpha/N, N-2)}}{N-2 + t^2_{(\alpha/N, N-2)}}}$$

Statistical-based – Likelihood Approach

- Assume the data set D contains samples from a mixture of two probability distributions:
 - M (majority distribution)
 - A (anomalous distribution)
- General Approach:
 - Initially, assume all the data points belong to M
 - Let $L_t(D)$ be the log likelihood of D at time t
 - For each point x_t that belongs to M , move it to A
 - Let $L_{t+1}(D)$ be the new log likelihood.
 - Compute the difference, $\Delta = L_t(D) - L_{t+1}(D)$
 - If $\Delta > c$ (some threshold), then x_t is declared as an anomaly and moved permanently from M to A

Statistical-based – Likelihood Approach

- Data distribution, $D = (1 - \lambda) M + \lambda A$
- M is a probability distribution estimated from data
 - Can be based on any modeling method (naïve Bayes, maximum entropy, etc.)
- A is initially assumed to be uniform distribution
- Likelihood at time t :

$$L_t(D) = \prod_{i=1}^N P_D(x_i) = \left((1 - \lambda)^{|M_t|} \prod_{x_i \in M_t} P_{M_t}(x_i) \right) \left(\lambda^{|A_t|} \prod_{x_i \in A_t} P_{A_t}(x_i) \right)$$

$$LL_t(D) = |M_t| \log(1 - \lambda) + \sum_{x_i \in M_t} \log P_{M_t}(x_i) + |A_t| \log \lambda + \sum_{x_i \in A_t} \log P_{A_t}(x_i)$$

Strengths/Weaknesses of Statistical Approaches

Pros

- Firm mathematical foundation
- Can be very efficient
- Good results if distribution is known

Cons

- In many cases, data distribution may not be known
- For high dimensional data, it may be difficult to estimate the true distribution
- Anomalies can distort the parameters of the distribution
 - Mean and standard deviation are very sensitive to outliers

Depth-based Approaches

Depth-based Approaches

- General idea
 - Search for outliers at the border of the data space but independent of statistical distributions
 - Organize data objects in convex hull layers
 - Outliers are objects on outer layers
- Basic assumption
 - Outliers are located at the border of the data space
 - Normal objects are in the center of the data space

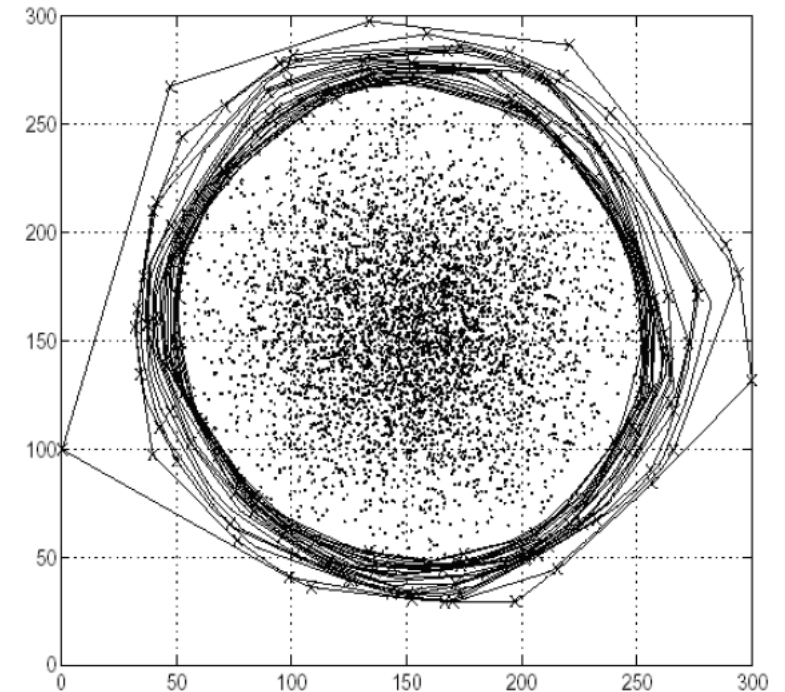

Depth-based Approaches

Model [Tukey 1977]

- Points on the convex hull of the full data space have depth = 1
- Points on the convex hull of the data set after removing all points with depth = 1 have depth = 2
- — ...
- Points having a depth $\leq k$ are reported as outliers

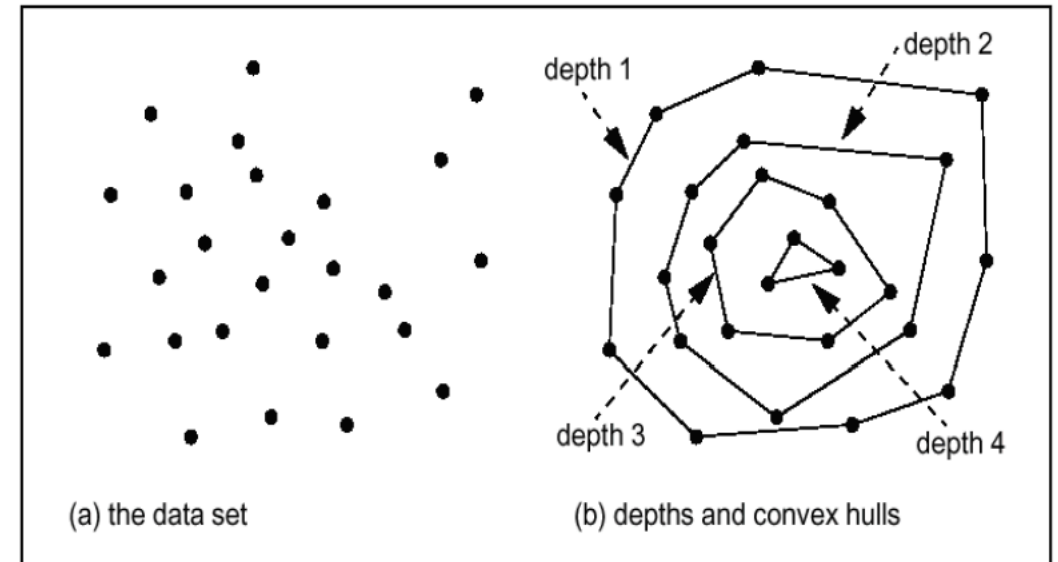

Depth-based Approaches

- Similar idea like classical statistical approaches ($k = 1$ distributions) but independent from the chosen kind of distribution
- Convex hull computation is usually only efficient in 2D / 3D spaces
- Originally outputs a label but can be extended for scoring easily (take depth as scoring value)
- Uses a global reference set for outlier detection

- Sample algorithms
 - ISODEPTH [Ruts and Rousseeuw 1996]
 - FDC [Johnson et al. 1998]

Deviation-based Approaches

Deviation-based Approaches

- General idea
 - Given a set of data points (local group or global set)
 - Outliers are points that do not fit to the general characteristics of that set, i.e., the variance of the set is minimized when removing the outliers
- Basic assumption
 - Outliers are the outermost points of the data set

Deviation-based Approaches

Model [Arning et al. 1996]

- Given a smoothing factor $SF(I)$ that computes for each $I \subseteq DB$ how much the variance of DB is decreased when I is removed from DB
- With equal decrease in variance, a smaller exception set E is better
- The outliers are the elements of $E \subseteq DB$ for which the following holds: $SF(E) \geq SF(I)$ for all $I \subseteq DB$

Discussion:

- Similar idea like classical statistical approaches ($k = 1$ distributions) but independent from the chosen kind of distribution
- Naïve solution is in $O(2^n)$ for n data objects
- Heuristics like random sampling or best first search are applied
- Applicable to any data type (depends on the definition of SF)
- Originally designed as a global method
- Outputs a labeling

Distance-based Approaches

Distance-based Approaches

- General Idea
 - Judge a point based on the distance(s) to its neighbors
 - Several variants proposed
- Basic Assumption
 - Normal data objects have a dense neighborhood
 - Outliers are far apart from their neighbors, i.e., have a less dense neighborhood

Distance-based Approaches

- Several different techniques
- An object is an outlier if a specified fraction of the objects is more than a specified distance away (Knorr, Ng 1998)
 - Some statistical definitions are special cases of this
- The outlier score of an object is the distance to its k -th nearest neighbor

One Nearest Neighbor - One Outlier

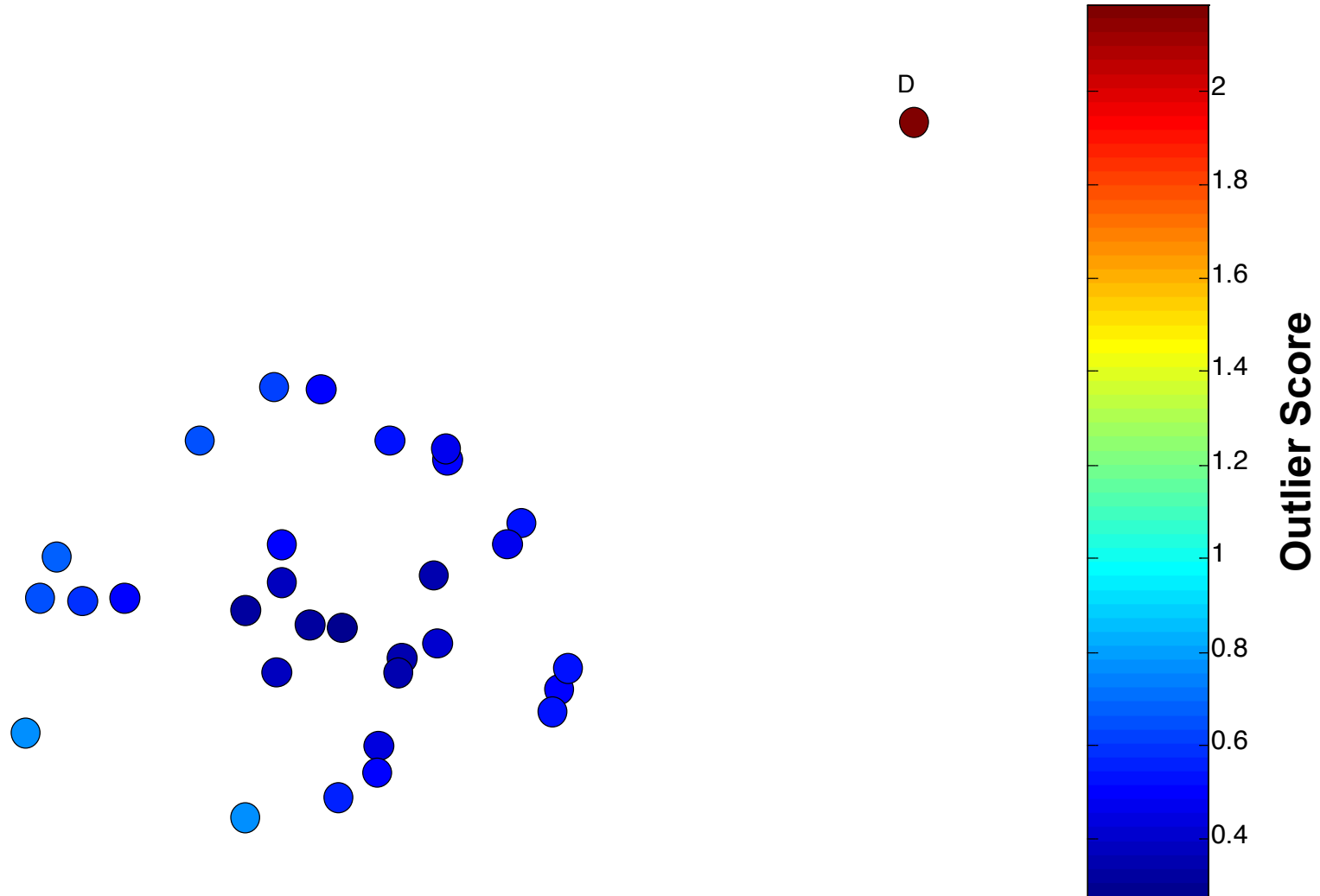

One Nearest Neighbor - Two Outliers

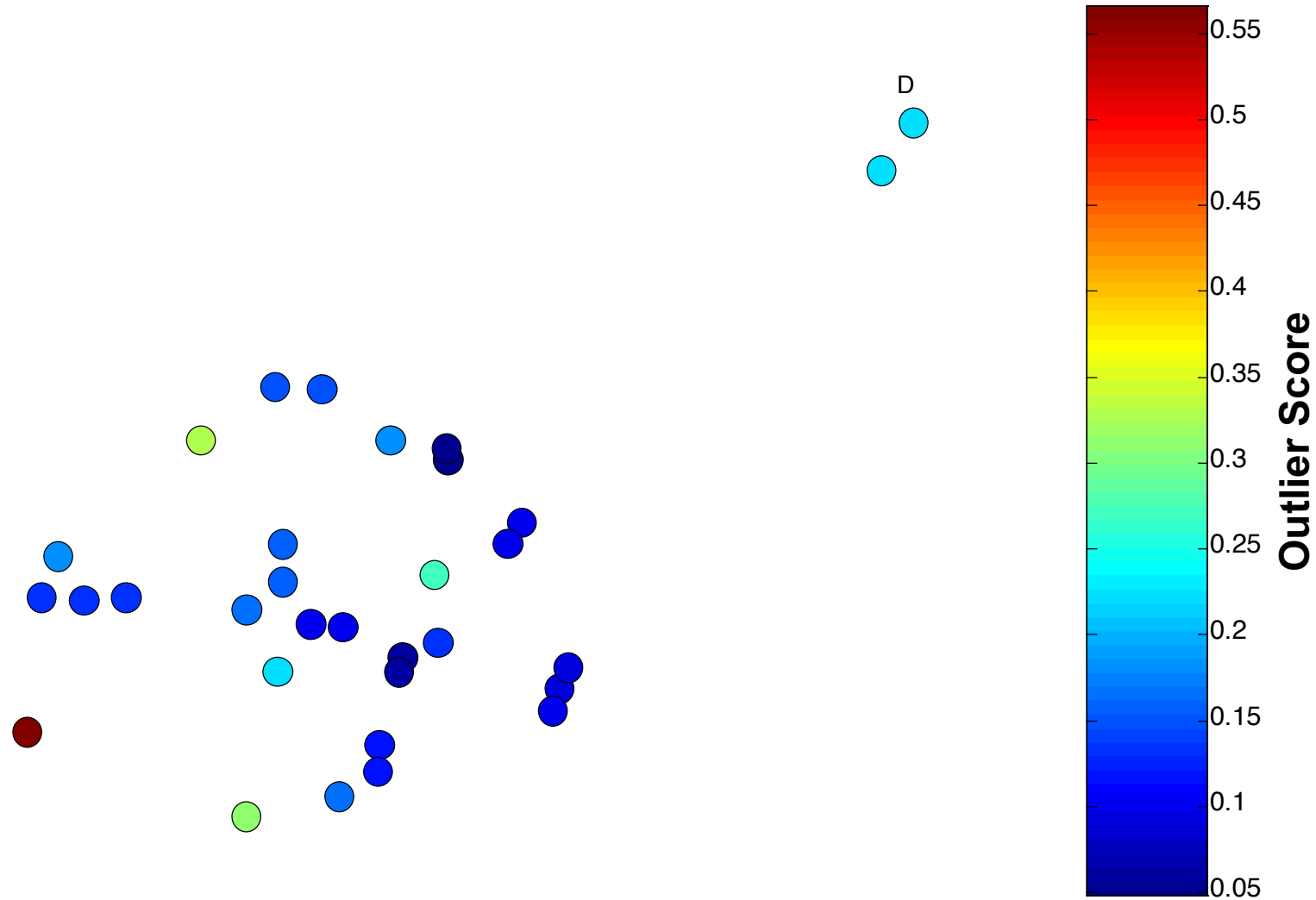

Five Nearest Neighbors - Small Cluster

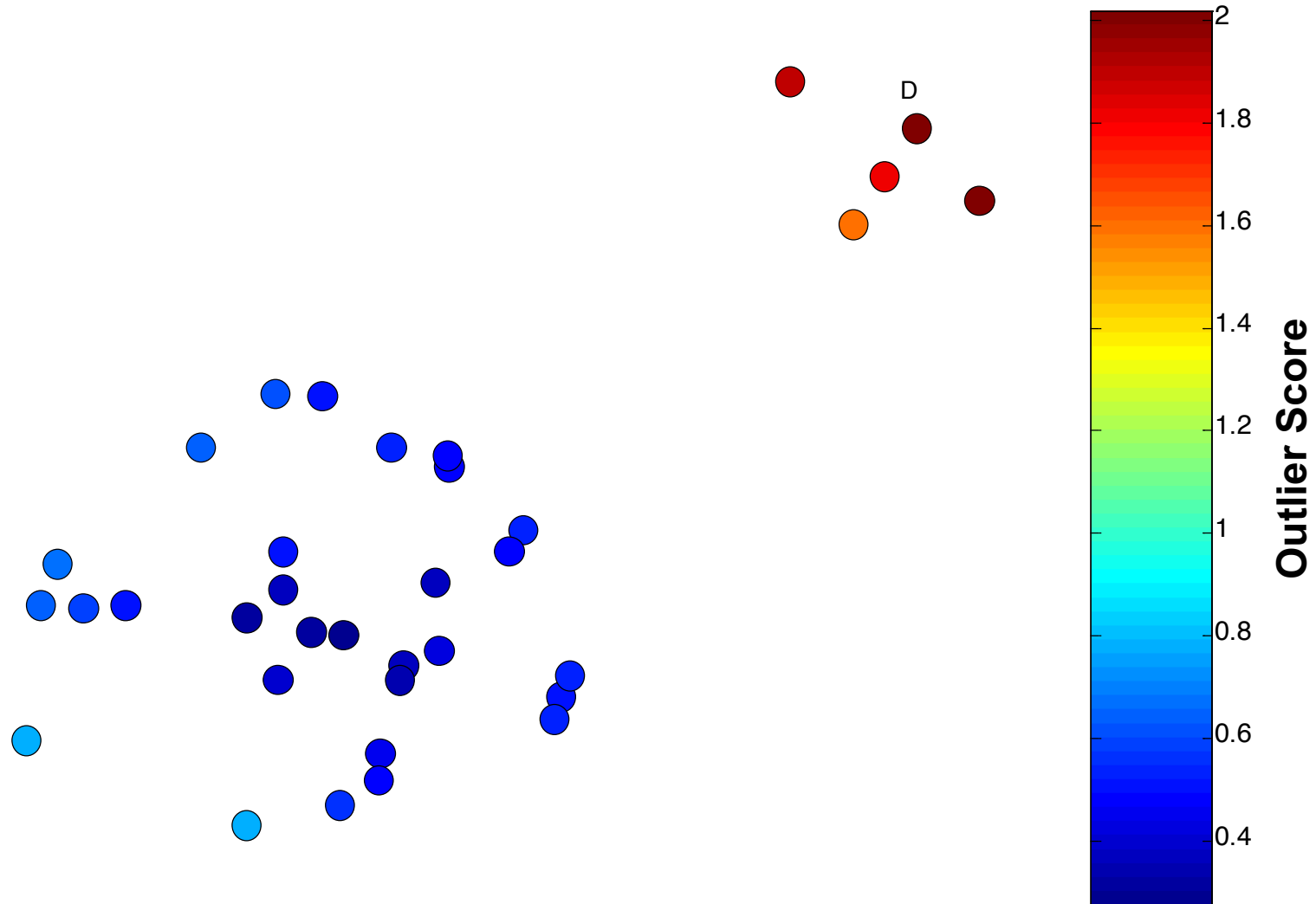

Five Nearest Neighbors - Differing Density

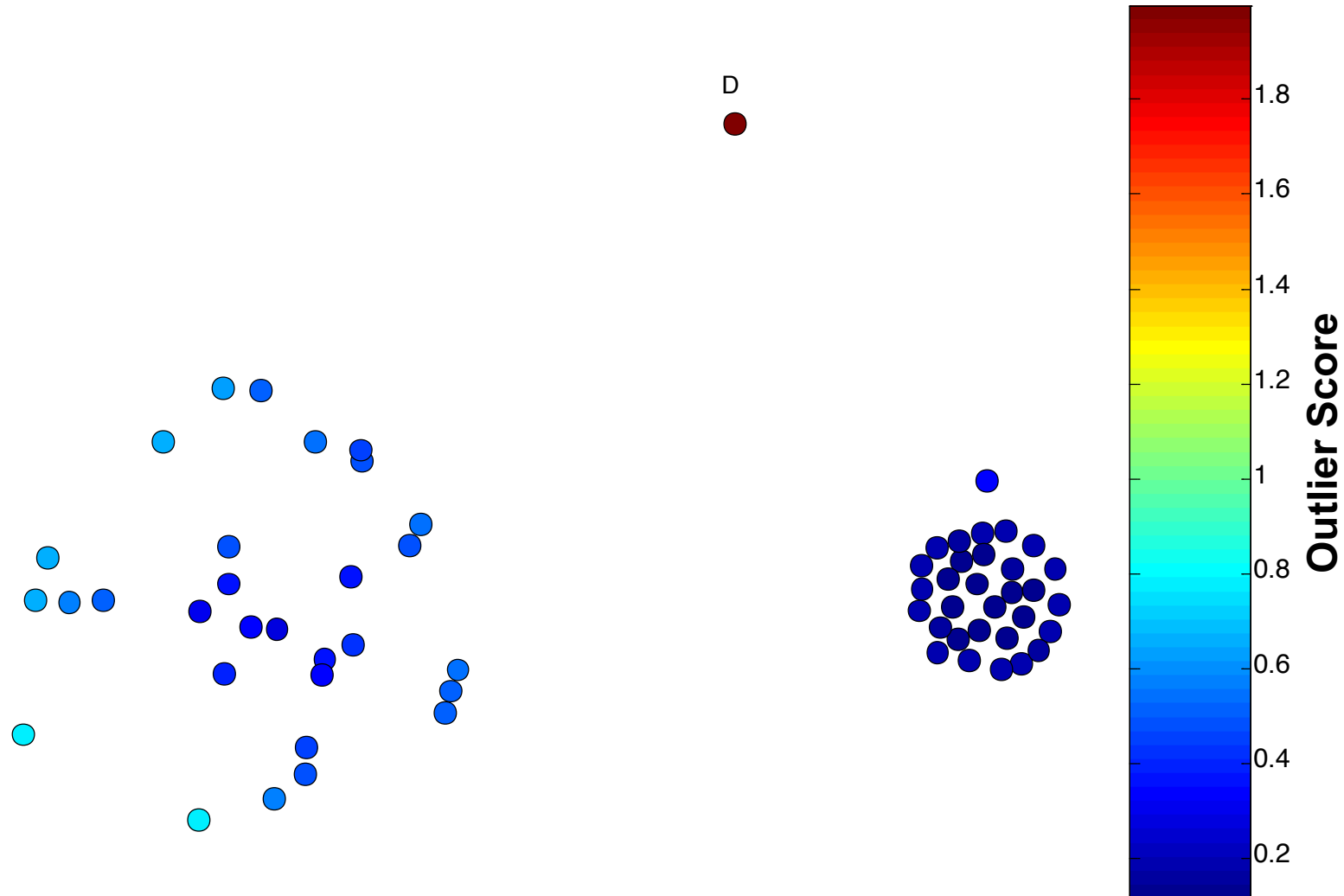

Distance-based Approaches

DB(ϵ, π)-Outliers

- Basic model [Knorr and Ng 1997]
- Given a radius ϵ and a percentage π
- A point p is considered an outlier if at most π percent of all other points have a distance to p less than ϵ , *i.e.*, *it is close to few points*

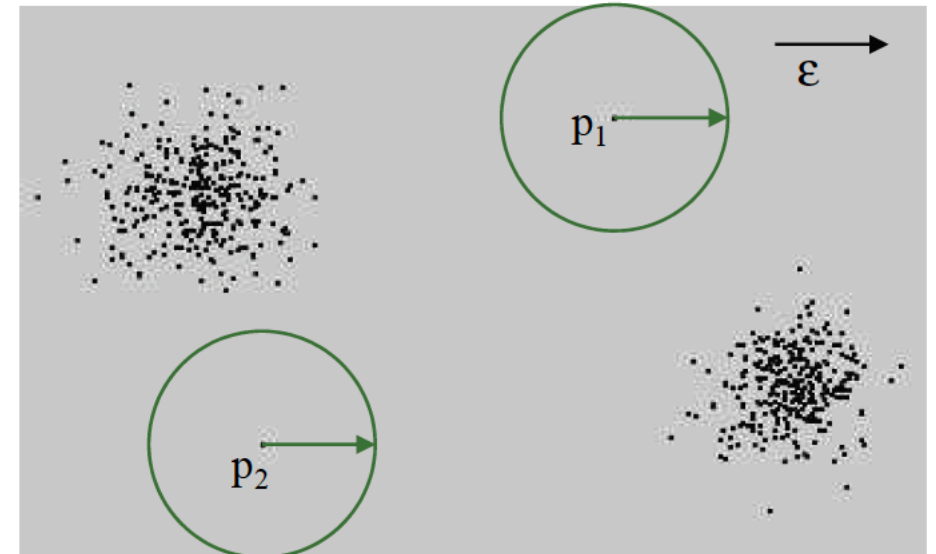

$$\text{OutlierSet}(\epsilon, \pi) = \left\{ p \mid \frac{\text{Card}(\{q \in DB \mid \text{dist}(p, q) < \epsilon\})}{\text{Card}(DB)} \leq \pi \right\}$$

range-query with radius ϵ

Distance-based Approaches - Algorithms

- Index-based [Knorr and Ng 1998]
 - Compute distance range join using spatial index structure
 - Exclude point from further consideration if its ε -neighborhood contains more than $\text{Card}(\text{DB}) \pi$ points
- Nested-loop based [Knorr and Ng 1998]
 - Divide buffer in two parts
 - Use second part to scan/compare all points with the points from the first part
- Grid-based [Knorr and Ng 1998]
 - Build grid such that any two points from the same grid cell have a distance of at most ε to each other
 - Points need only compared with points from neighboring cells

Outlier scoring based on kNN distances

General models

- Take the kNN distance of a point as its outlier score [Ramaswamy et al 2000]
- Aggregate the distances of a point to all its 1NN, 2NN, ..., kNN as an outlier score [Angiulli and Pizzuti 2002]

Algorithms - General approaches

- Nested-Loop
 - Naïve approach: For each object: compute kNNs with a sequential scan
 - Enhancement: use index structures for kNN queries
- Partition-based
 - Partition data into micro clusters
 - Aggregate information for each partition (e.g. minimum bounding rectangles)
 - Allows to prune micro clusters that cannot qualify when searching for the kNNs of a particular point

Outlier Detection using In-degree Number

- Idea: Construct the kNN graph for a data set
 - Vertices: data points
 - Edge: if $q \in kNN(p)$ then there is a directed edge from p to q
 - A vertex that has an indegree less than equal to T (user threshold) is an outlier
- Discussion
 - The indegree of a vertex in the kNN graph equals to the number of reverse kNNs (RkNN) of the corresponding point
 - The RkNNs of a point p are those data objects having p among their kNNs
 - Intuition of the model: outliers are
 - points that are among the kNNs of less than T other points
 - have less than T RkNNs
 - Outputs an outlier label
 - Is a local approach (depending on user defined parameter k)

Strengths/Weaknesses of Distance-Based Approaches

Pros

- Simple

Cons

- Expensive – $O(n^2)$
- Sensitive to parameters
- Sensitive to variations in density
- Distance becomes less meaningful in high-dimensional space

Density-based Approaches

Density-based Approaches

- General idea
 - Compare the density around a point with the density around its local neighbors
 - The relative density of a point compared to its neighbors is computed as an outlier score
 - Approaches differ in how to estimate density
- Basic assumption
 - The density around a normal data object is similar to the density around its neighbors
 - The density around an outlier is considerably different to the density around its neighbors

Density-based Approaches

- **Density-based Outlier:** The outlier score of an object is the inverse of the density around the object.
 - Can be defined in terms of the k nearest neighbors
 - One definition: Inverse of distance to k th neighbor
 - Another definition: Inverse of the average distance to k neighbors
 - DBSCAN definition
- If there are regions of different density, this approach can have problems

Relative Density Outlier Scores

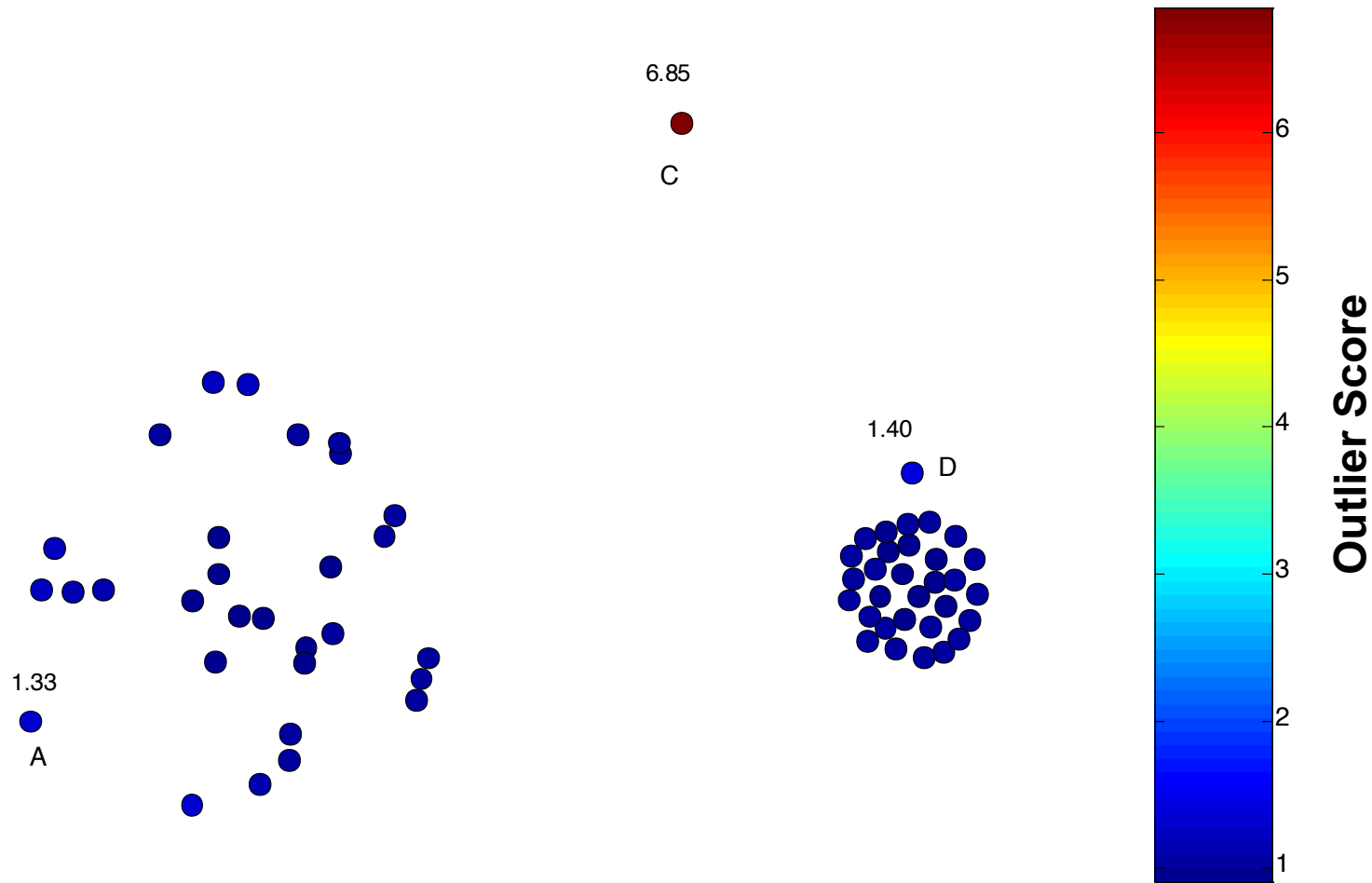

Relative Density

- Consider the density of a point relative to that of its k nearest neighbors

$$\text{average relative density}(\mathbf{x}, k) = \frac{\text{density}(\mathbf{x}, k)}{\sum_{\mathbf{y} \in N(\mathbf{x}, k)} \text{density}(\mathbf{y}, k) / |N(\mathbf{x}, k)|}. \quad (10.7)$$

Algorithm 10.2 Relative density outlier score algorithm.

- 1: $\{k$ is the number of nearest neighbors}
 - 2: **for all** objects \mathbf{x} **do**
 - 3: Determine $N(\mathbf{x}, k)$, the k -nearest neighbors of \mathbf{x} .
 - 4: Determine $\text{density}(\mathbf{x}, k)$, the density of \mathbf{x} , using its nearest neighbors, i.e., the objects in $N(\mathbf{x}, k)$.
 - 5: **end for**
 - 6: **for all** objects \mathbf{x} **do**
 - 7: Set the *outlier score* $(\mathbf{x}, k) = \text{average relative density}(\mathbf{x}, k)$ from Equation 10.7.
 - 8: **end for**
-

Local Outlier Factor (LOF) [Breunig et al. 1999], [Breunig et al. 2000]

Motivation:

- Distance-based outlier detection models have problems with different densities
- How to compare the neighborhood of points from areas of different densities?

Example

- DB(ϵ, π)-outlier model
 - Parameters ϵ and π cannot be chosen so that o_2 is an outlier but none of the points in cluster C_1 (e.g. q) is an outlier
- Outliers based on kNN-distance
 - kNN-distances of objects in C_1 (e.g. q) are larger than the kNN-distance of o_2

Solution: consider relative density

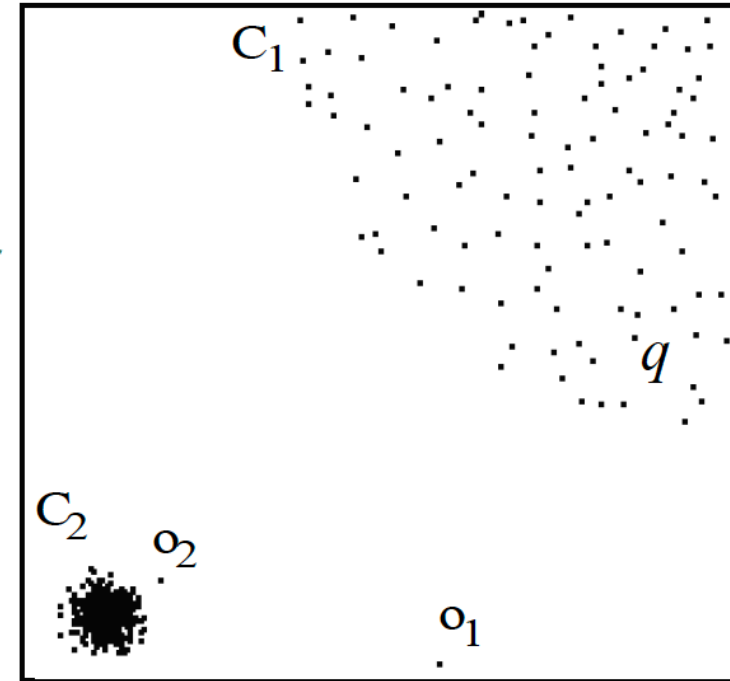

Local Outlier Factor (LOF)

- For each point, compute the density of its local neighborhood
- Compute local outlier factor (LOF) of a sample p as the average of the ratios of the density of sample p and the density of its nearest neighbors
- Outliers are points with largest LOF value

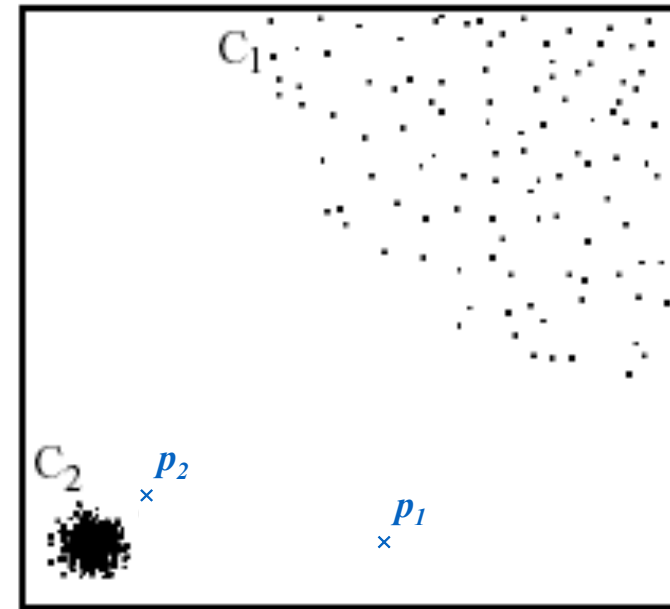

In the NN approach, p_2 is not considered as outlier, while LOF approach find both p_1 and p_2 as outliers

Local Outlier Factor (LOF)

- Reachability distance
 - Introduces a smoothing factor

$$\text{reach-dist}_k(p, o) = \max \{k\text{-distance}(o), \text{dist}(p, o)\}$$

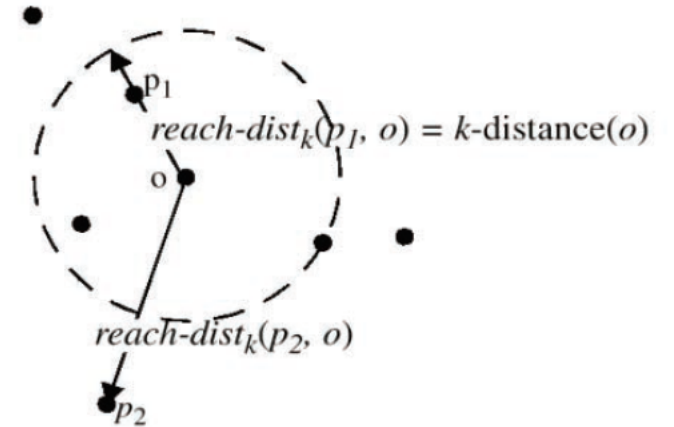

- Local reachability distance (*lrd*) of point p
 - Inverse of the average reach-dists of the kNNs of p

$$\text{lrd}_k(p) = 1 / \left(\frac{\sum_{o \in kNN(p)} \text{reach-dist}_k(p, o)}{\text{Card}(kNN(p))} \right)$$

- Local outlier factor (LOF) of point p
 - Average ratio of *lrds* of neighbors of p and *lrd* of p

$$\text{LOF}_k(p) = \frac{\sum_{o \in kNN(p)} \frac{\text{lrd}_k(o)}{\text{lrd}_k(p)}}{\text{Card}(kNN(p))}$$

Local Outlier Factor (LOF)

Properties

- $LOF \approx 1$: point is in a cluster (region with homogeneous density around the point and its neighbors)
- $LOF \gg 1$: point is an outlier

Discussion

- Choice of k (MinPts in the original paper) specifies the reference set
- Originally implements a *local* approach (resolution depends on the user's choice for k)
- Outputs a scoring (assigns an LOF value to each point)

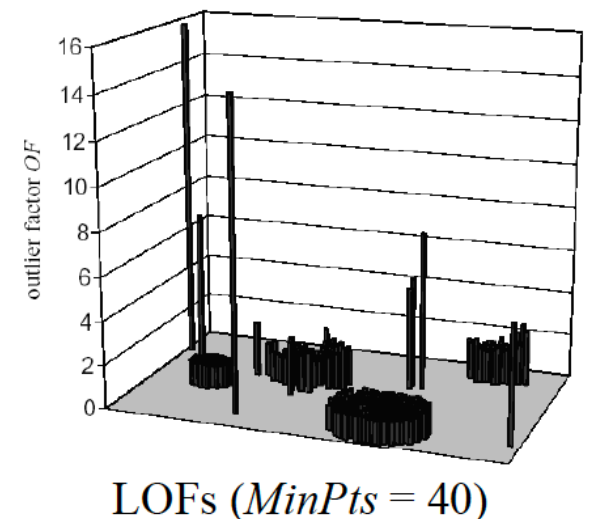
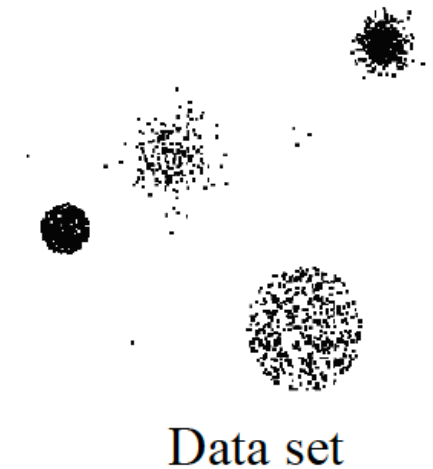

Mining Top-n Local Outliers [Jin et al. 2001]

Idea:

- Usually, a user is only interested in the **top-n** outliers
- Do not compute the LOF for all data objects => save runtime

Method

- Compress data points into micro clusters using the CFs of BIRCH [Zhang et al. 1996]
- Derive upper and lower bounds of the reachability distances, lrd-values, and LOF-values for points within a micro clusters
- Compute upper and lower bounds of LOF values for micro clusters and sort results w.r.t. ascending lower bound
- Prune micro clusters that cannot accommodate points among the top-n outliers (n highest LOF values)
- Iteratively refine remaining micro clusters and prune points accordingly

Connectivity-based outlier factor (COF) [Tang et al. 2002]

- Motivation
 - In regions of low density, it may be hard to detect outliers
 - Choose a low value for k is often not appropriate
- Solution
 - Treat “low density” and “isolation” differently
- Example

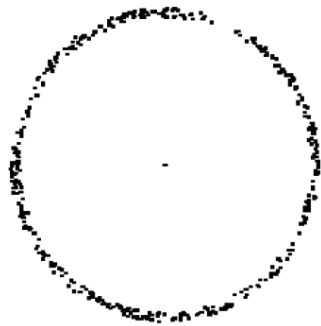

Data set

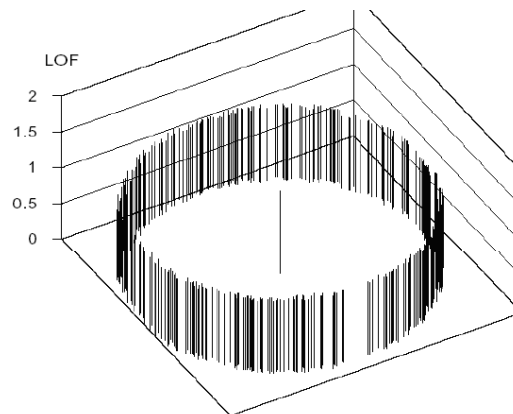

LOF

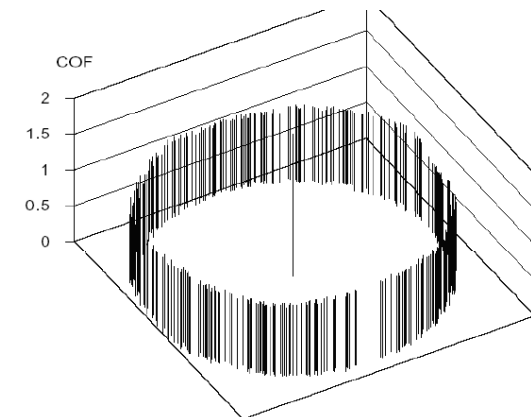

COF

Influenced Outlierness (INFLO) [Jin et al. 2006]

Motivation

- If clusters of different densities are not clearly separated, LOF will have problems

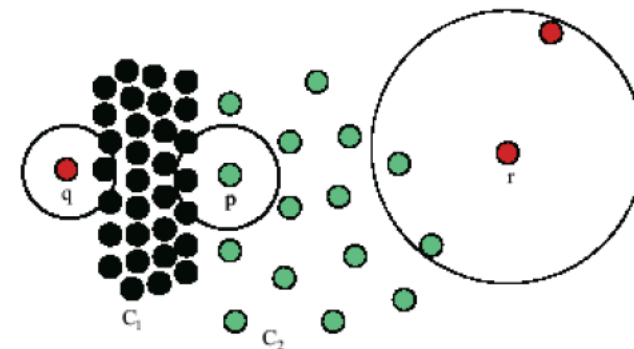

Point p will have a higher LOF than points q or r which is counter intuitive

Idea

- Take symmetric neighborhood relationship into account
- Influence space $kIS(p)$ of a point p includes its k NNs ($kNN(p)$) and its reverse k NNs ($RkNN(p)$)

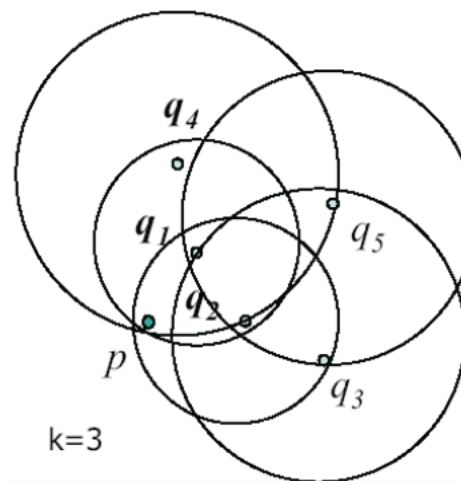

$$\begin{aligned} kIS(p) &= kNN(p) \cup RkNN(p) \\ &= \{q_1, q_2, q_4\} \end{aligned}$$

Influenced Outlierness (INFLO) [Jin et al. 2006]

Model

- Density is simply measured by the inverse of the kNN distance, i.e.,
 - $den(p) = 1/k\text{-distance}(p)$

- Influenced outlierness of a point p

$$INFLO_k(p) = \frac{\frac{\sum_{o \in kIS(p)} den(o)}{Card(kIS(p))}}{den(p)}$$

- INFLO takes the ratio of the average density of objects in the neighborhood of a point p (i.e., in $kNN(p) \cup RkNN(p)$) to p 's density

Proposed algorithms for mining top-n outliers

- Index-based
- Two-way approach
- Micro cluster based approach

Influenced Outlierness (INFLO) [Jin et al. 2006]

Properties

- Similar to LOF
- $\text{INFLO} \approx 1$: point is in a cluster
- $\text{INFLO} \gg 1$: point is an outlier

Discussion

- Outputs an outlier score
- Originally proposed as a *local* approach (resolution of the reference set kIS can be adjusted by the user setting parameter k)

Strengths/Weaknesses of Density-Based Approaches

Pros

- Simple

Cons

- Expensive – $O(n^2)$
- Sensitive to parameters
- Density becomes less meaningful in high-dimensional space

Clustering-based Approaches

Clustering and Anomaly Detection

- Are outliers just a side product of some clustering algorithms?
 - Many clustering algorithms do not assign all points to clusters but account for noise objects (e.g. DBSCAN, OPTICS)
 - Look for outliers by applying one algorithm and retrieve the noise set
- Problem:
 - Clustering algorithms are optimized to find clusters rather than outliers
 - Accuracy of outlier detection depends on how good the clustering algorithm captures the structure of clusters
 - A set of many abnormal data objects that are similar to each other would be recognized as a cluster rather than as noise/outliers

Clustering-Based Approaches

- **Clustering-based Outlier:** An object is a cluster-based outlier if it does not strongly belong to any cluster
 - For prototype-based clusters, an object is an outlier if it is not close enough to a cluster center
 - For density-based clusters, an object is an outlier if its density is too low
 - For graph-based clusters, an object is an outlier if it is not well connected
- Other issues include the impact of outliers on the clusters and the number of clusters

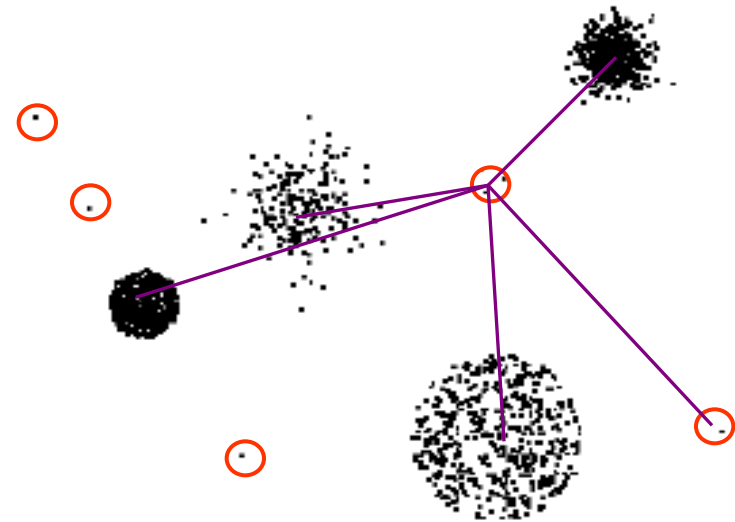

Distance of Points from Closest Centroids

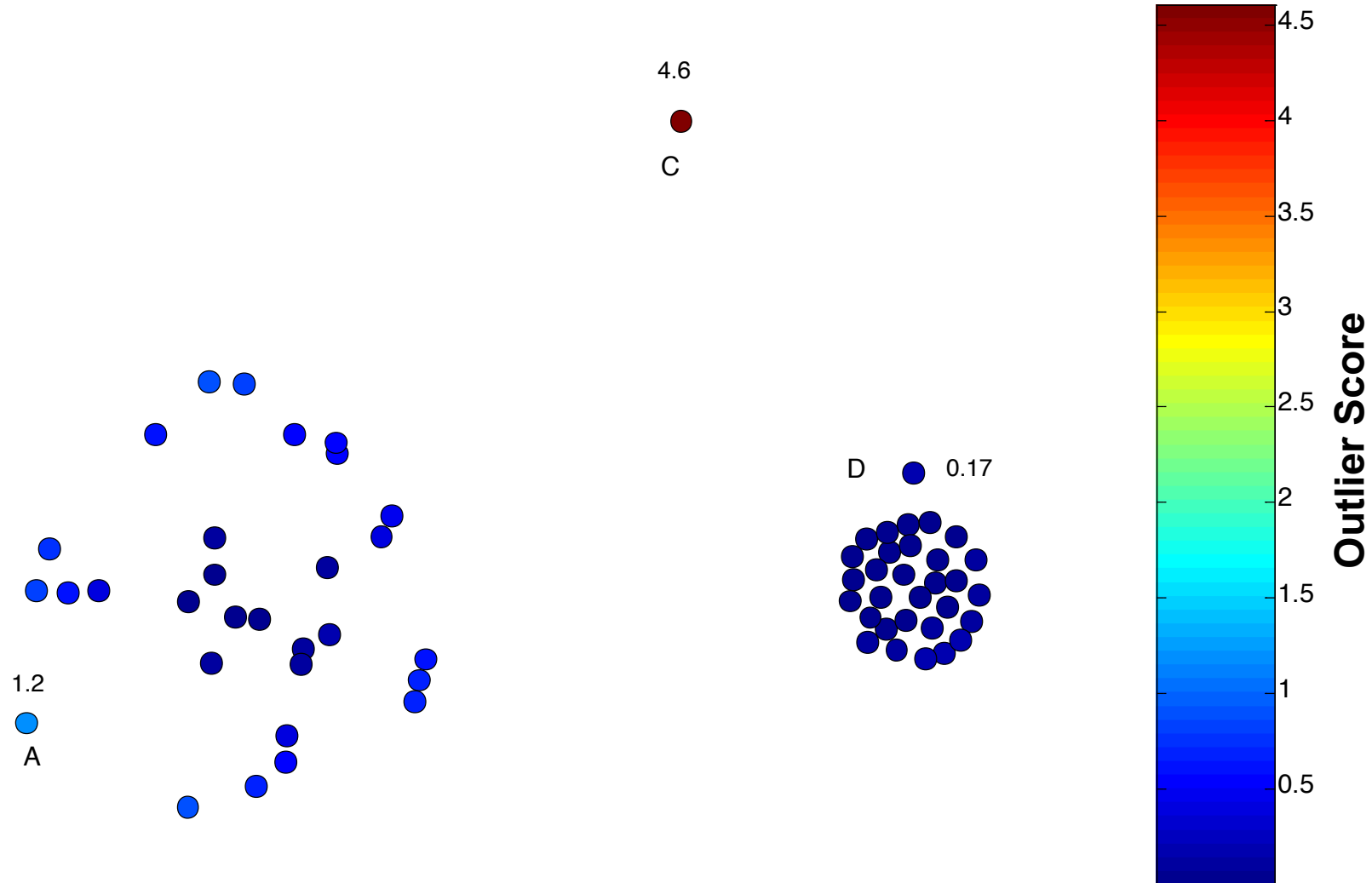

Relative Distance of Points from Closest Centroid

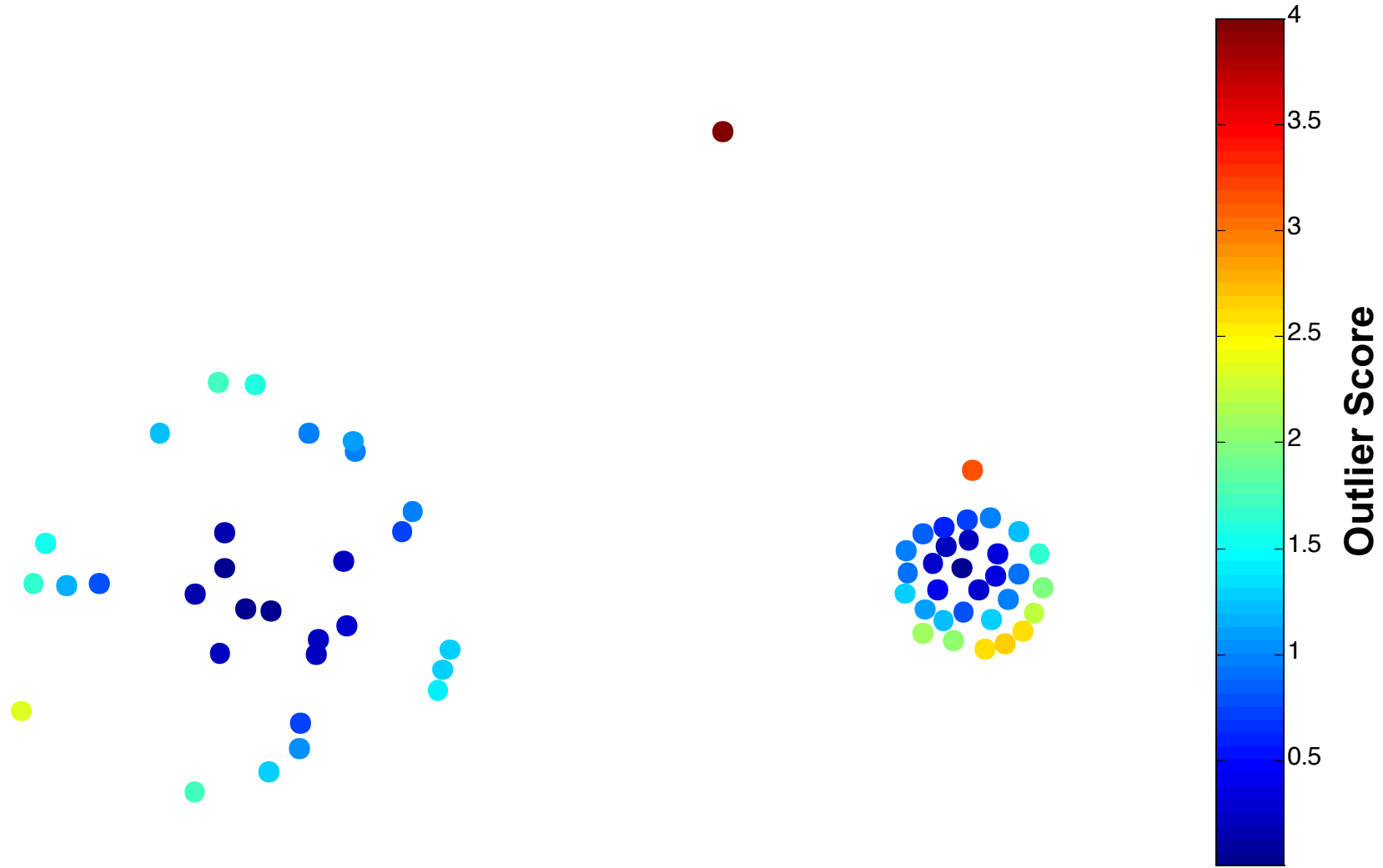

Strengths/Weaknesses of Clustering-Based Approaches

Pros

- Simple
- Many clustering techniques can be used

Cons

- Can be difficult to decide on a clustering technique
- Can be difficult to decide on number of clusters
- Outliers can distort the clusters

High-dimensional Approaches

Challenges

Curse of dimensionality

- Relative contrast between distances decreases with increasing dimensionality
- Data is very sparse, almost all points are outliers
- Concept of neighborhood becomes meaningless

Solutions

- Use more robust distance functions and find full-dimensional outliers
- Find outliers in projections (subspaces) of the original feature space

ABOD – Angle-based Outlier Degree [Kriegel et al. 2008]

- Angles are more stable than distances in high dimensional spaces (e.g. the popularity of cosine-based similarity measures for text data)
- Object o is an outlier if most other objects are located in similar directions
- Object o is no outlier if many other objects are located in varying directions

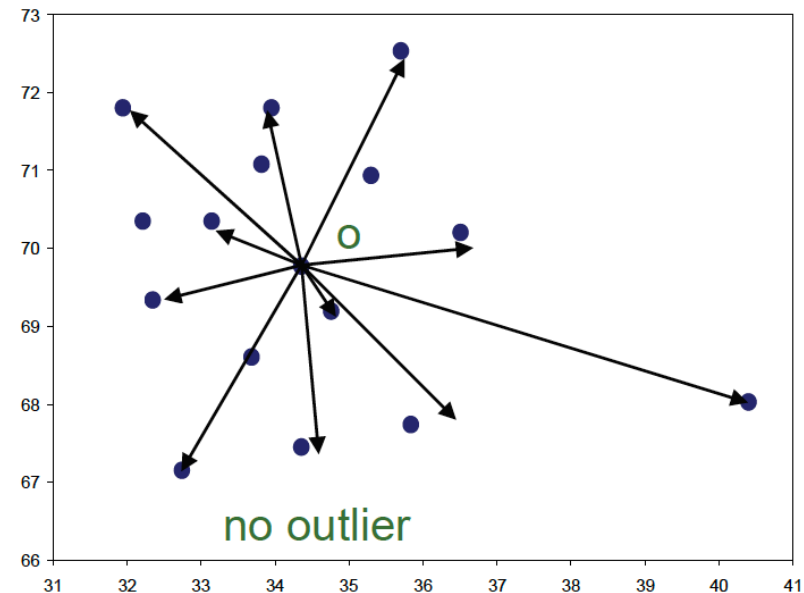
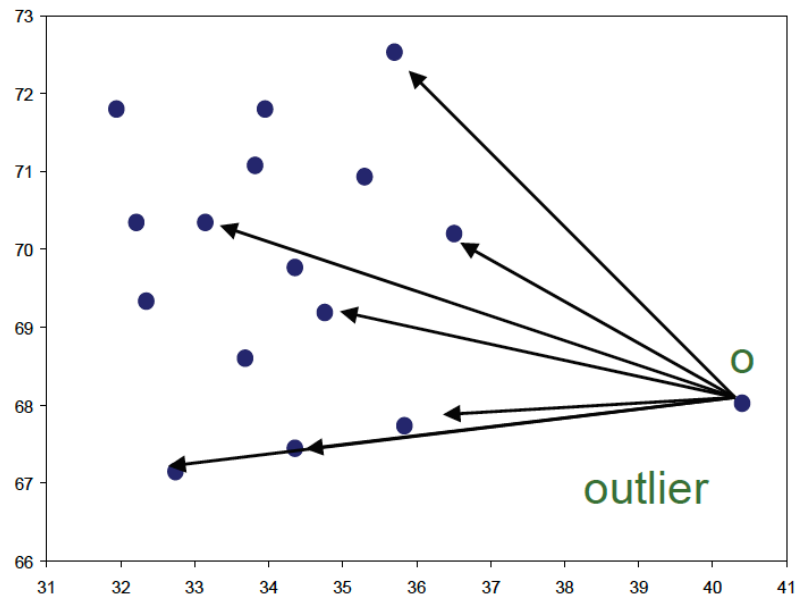

ABOD – Angle-based Outlier Degree [Kriegel et al. 2008]

- Basic assumption
 - Outliers are at the border of the data distribution
 - Normal points are in the center of the data distribution
- Model
 - Consider for a given point p the angle between any two instances x and y
 - Consider the spectrum of all these angles
 - The broadness of this spectrum is a score for the outlierness of a point

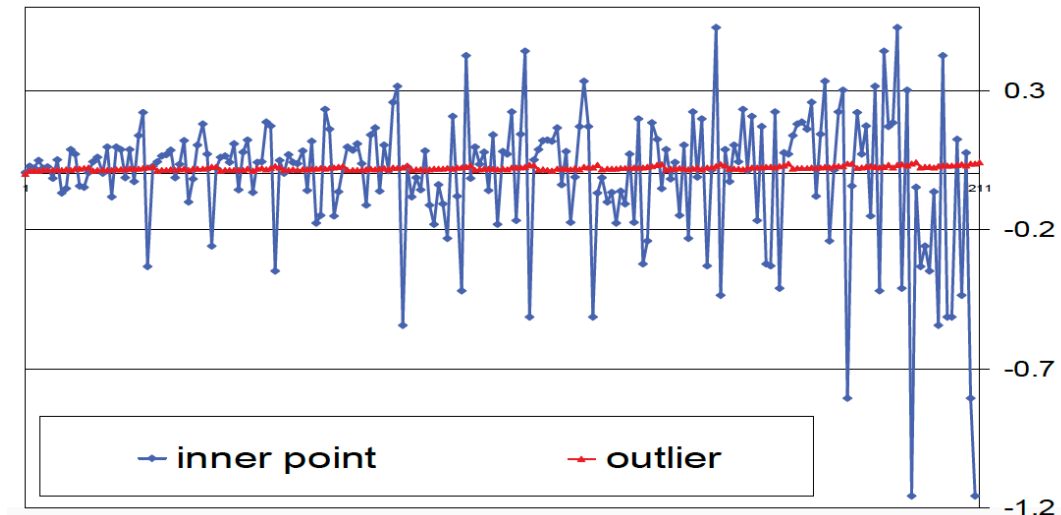
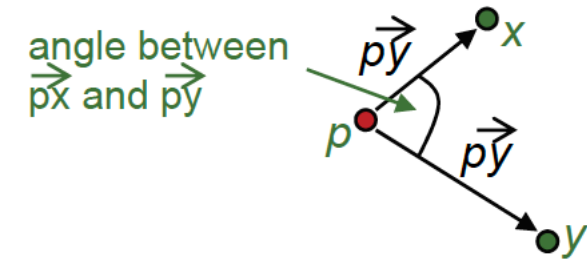

ABOD – Angle-based Outlier Degree [Kriegel et al. 2008]

- Model

- Measure the variance of the angle spectrum
- Weighted by the corresponding distances (for lower dimensional data sets where angles are less reliable)

$$ABOD(p) = VAR_{x,y \in DB} \left(\frac{\left\langle \begin{matrix} \rightarrow \\ xp, yp \end{matrix} \right\rangle}{\left\| \begin{matrix} \rightarrow \\ xp \end{matrix} \right\|^2 \cdot \left\| \begin{matrix} \rightarrow \\ yp \end{matrix} \right\|^2} \right)$$

- Properties

- Small ABOD => outlier
- High ABOD => no outlier

ABOD – Angle-based Outlier Degree [Kriegel et al. 2008]

Algorithms

- Naïve algorithm is in $O(n^3)$
- Approximate algorithm based on random sampling for mining top-n outliers
 - Do not consider all pairs of other points x, y in the database to compute the angles
 - Compute ABOD based on samples => lower bound of the real ABOD
 - Filter out points that have a high lower bound
 - Refine (compute the exact ABOD value) only for a small number of points

Discussion

- Global approach to outlier detection
- Outputs an outlier score

Grid-based Subspace Outlier Detection [Aggarwal and Yu 2000]

Model

- Partition data space by an equi-depth grid (Φ = number of cells in each dimension)
- Sparsity coefficient $S(C)$ for a k -dimensional grid cell C

$$S(C) = \frac{\text{count}(C) - n \cdot \left(\frac{1}{\Phi}\right)^k}{\sqrt{n \cdot \left(\frac{1}{\Phi}\right)^k \cdot \left(1 - \left(\frac{1}{\Phi}\right)^k\right)}}$$

- where $\text{count}(C)$ is the number of data objects in C
- $S(C) < 0 \Rightarrow \text{count}(C)$ is lower than expected
- Outliers are those objects that are located in lower-dimensional cells with negative sparsity coefficient

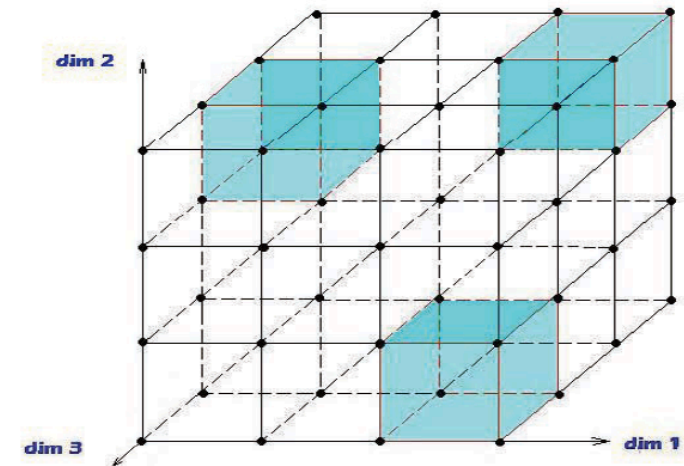

$\Phi = 3$

Grid-based Subspace Outlier Detection [Aggarwal and Yu 2000]

- Algorithm
 - Find the m grid cells (projections) with the lowest sparsity coefficients
 - Brute-force algorithm is *in* $O(\Phi d)$
 - Evolutionary algorithm (input: m and the dimensionality of the cells)
- Discussion
 - Results need not be the points from the optimal cells
 - Very coarse model (all objects that are in cell with less points than to be expected)
 - Quality depends on grid resolution and grid position
 - Outputs a labeling
 - Implements a global approach (key criterion: globally expected number of points within a cell)

Summary

- Different models are based on different assumptions
- Different models provide different types of output (labeling/scoring)
- Different models consider outlier at different resolutions (global/local)
- Thus, different models will produce different results
- A thorough and comprehensive comparison between different models and approaches is still missing

References

- Anomaly Detection. Chapter 10.
Introduction to Data Mining.

