

# DATA MINING 2

## (Deep) Neural Networks

---

Riccardo Guidotti

a.a. 2022/2023

*Slides edited from a set of slides titled “Introduction to Machine Learning and Neural Networks” by Davide Bacciu*



UNIVERSITÀ DI PISA

# Nonlinearly Separable Data

- Since  $f(w, x)$  is a linear combination of input variables, decision boundary is linear.
- For nonlinearly separable problems, the perceptron fails because no linear hyperplane can separate the data perfectly.
- An example of nonlinearly separable data is the XOR function.

XOR Data

$x_1$	$x_2$	$y$
0	0	-1
1	0	1
0	1	1
1	1	-1

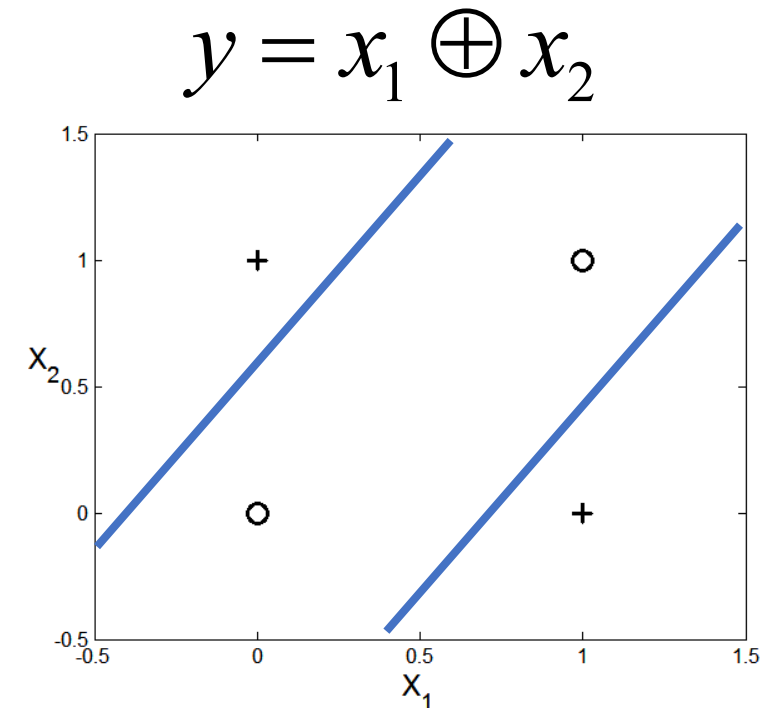

# Why Now?



(Big) Data



GPU

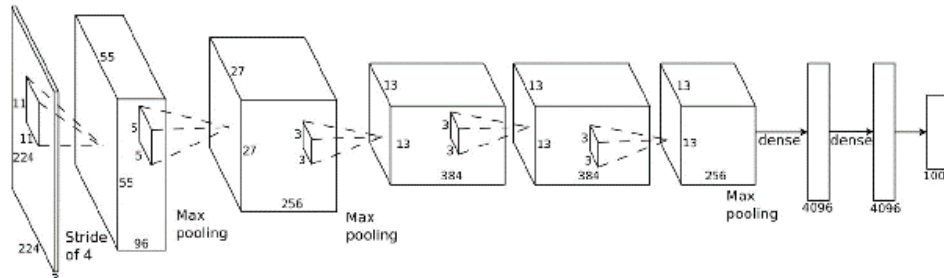

Theory

# A quick look on Deep Learning

---

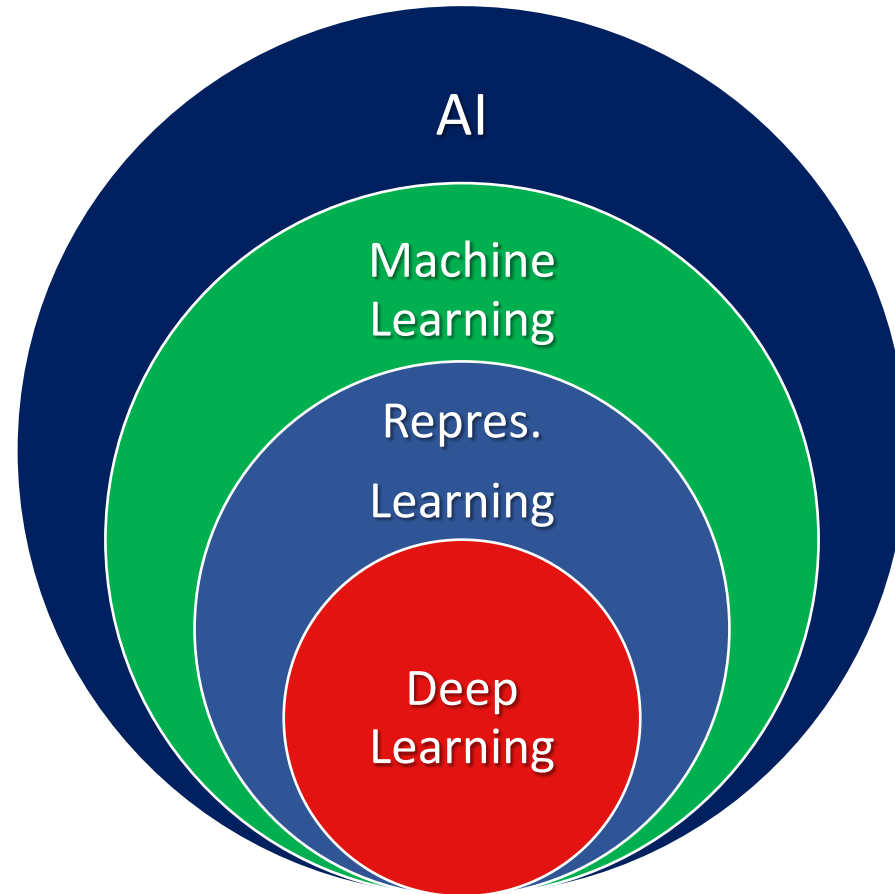

# Deep learning

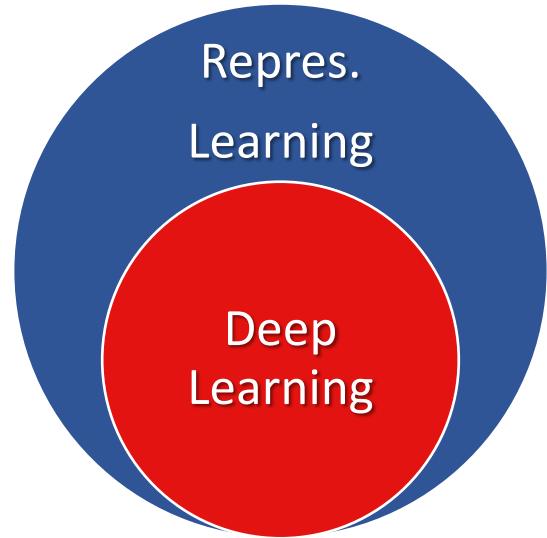

**Representation learning** methods that

- allow a machine to be fed with raw data and
- to automatically discover the representations needed for detection or classification.

## Raw representation



- Age 35
- Weight 65
- Income 23 k€
- Children 2
- Likes sport 0.3
- Likes reading 0.6
- Education high
- ...

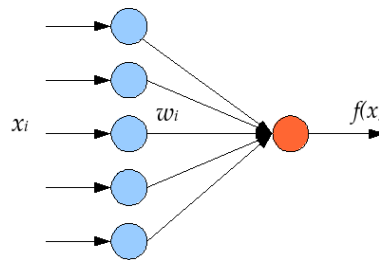

## Higher-level representation

- Young parent 0.9
- Fit sportsman 0.1
- High-educated reader 0.8
- Rich obese 0.0
- ...



# Multiple Levels Of Abstraction

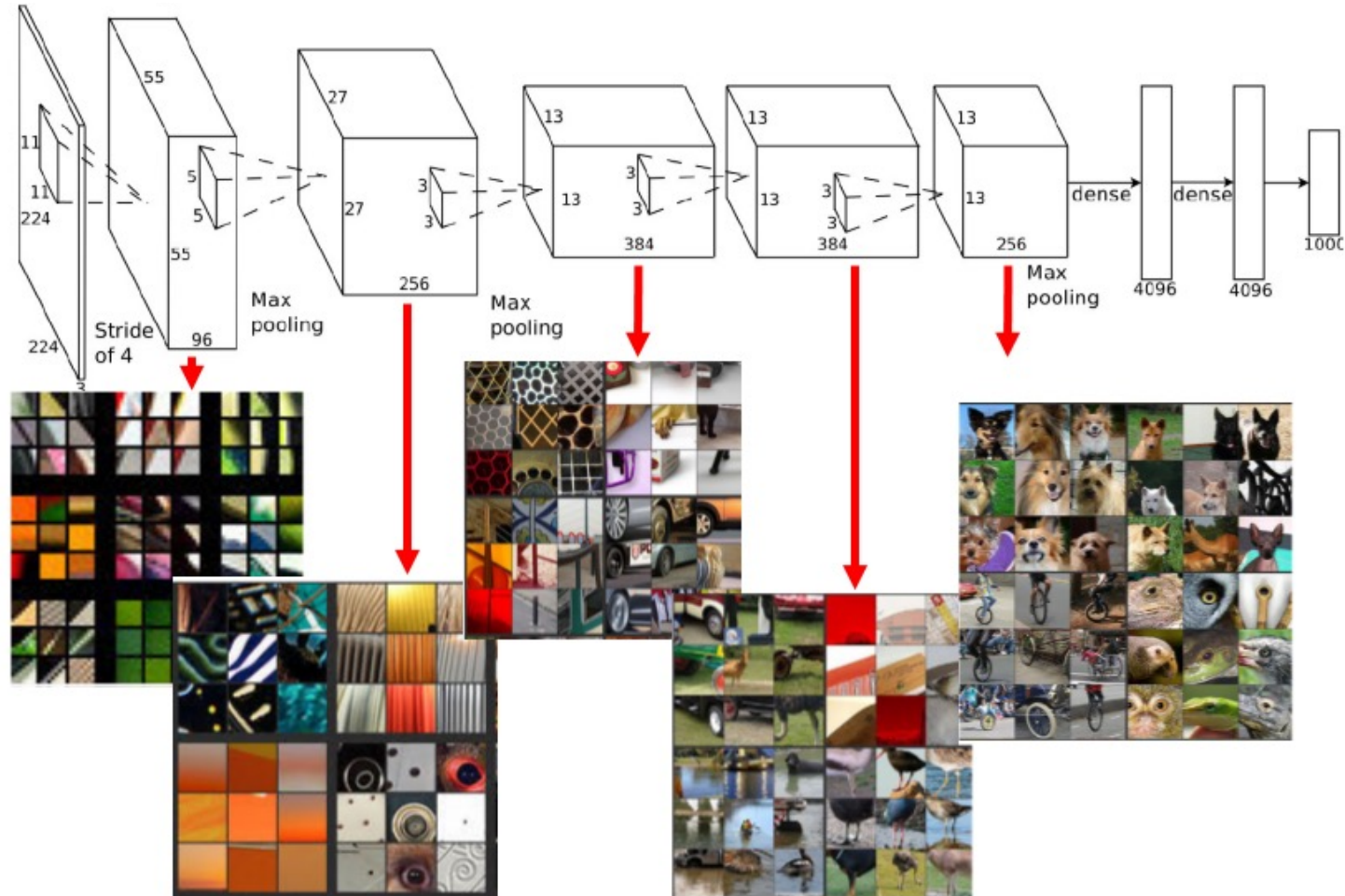

# Multilayer Neural Network

- **Hidden Layers:** intermediary layers between input and output layers.
- More general **activation functions** (sigmoid, linear, hyperbolic tangent, etc.).
- Multi-layer neural network can solve any type of classification task involving nonlinear decision surfaces.
- Perceptron is single layer.
- We can think to each hidden node as a perceptron that tries to construct one hyperplane, while the output node combines the results to return the decision boundary.

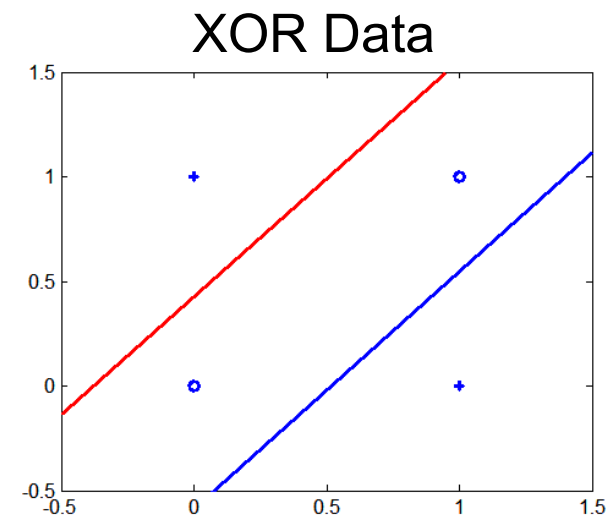
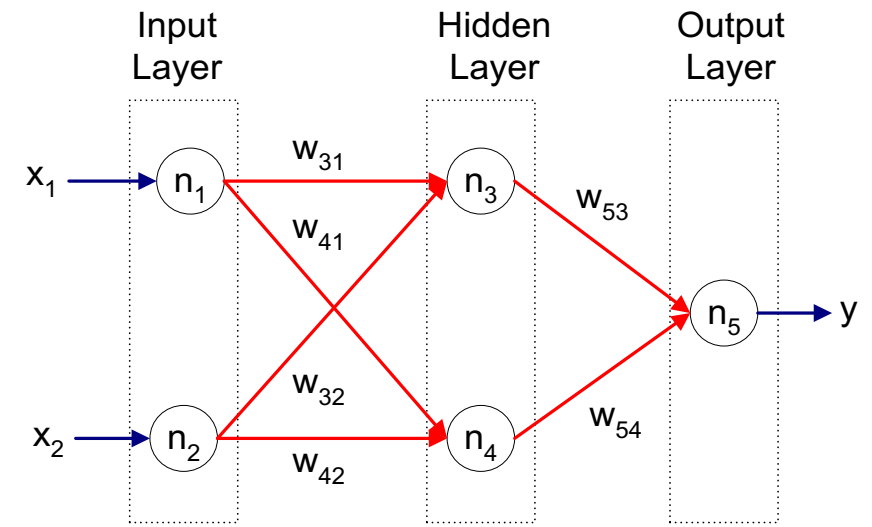

# General Structure of ANN

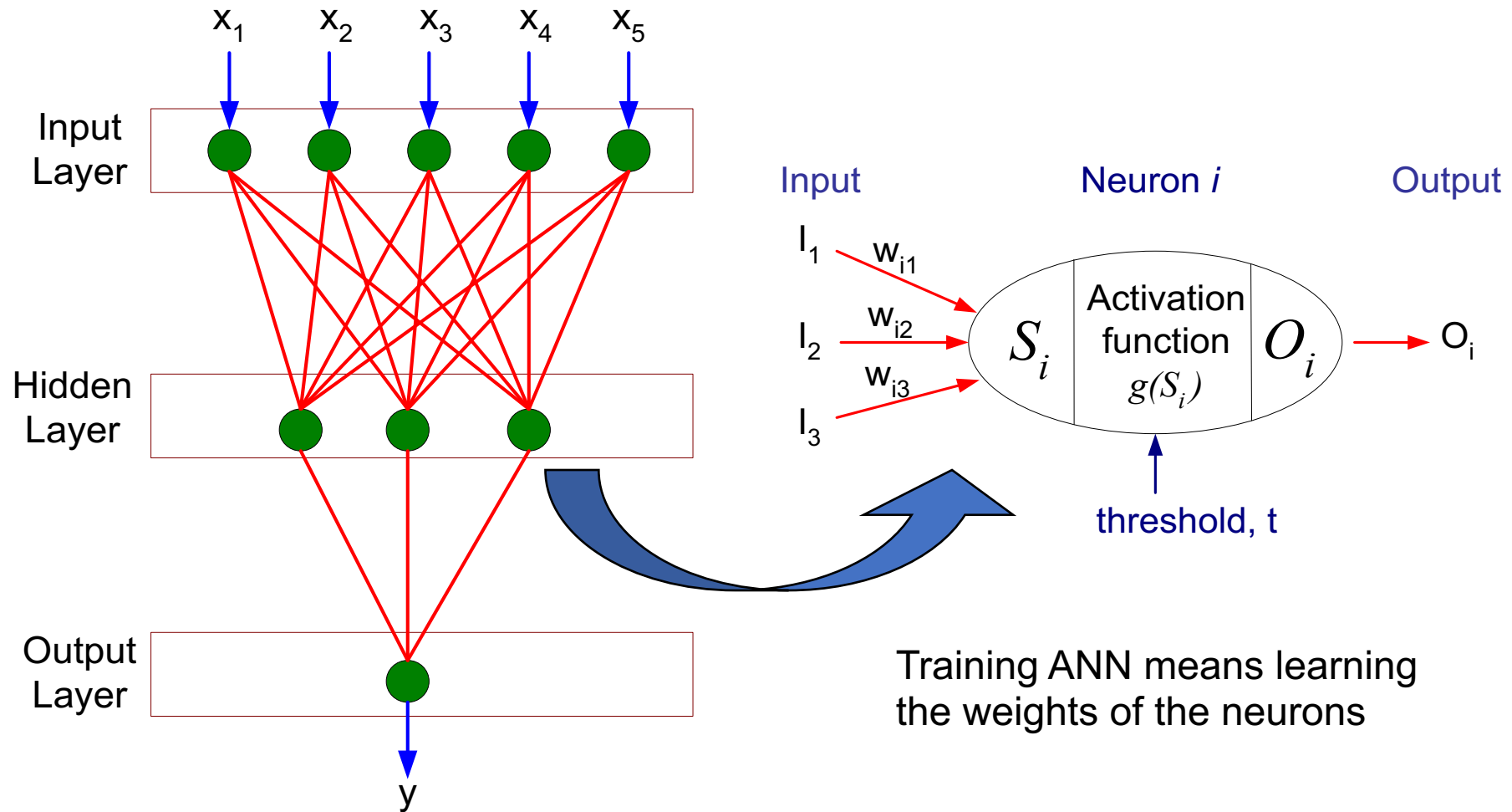



# Artificial Neural Networks (ANN)

- Various types of neural network topology
  - single-layered network (perceptron) versus multi-layered network
  - Feed-forward versus recurrent network
- Various types of activation functions (f)

$$Y = f\left(\sum_i w_i X_i\right)$$

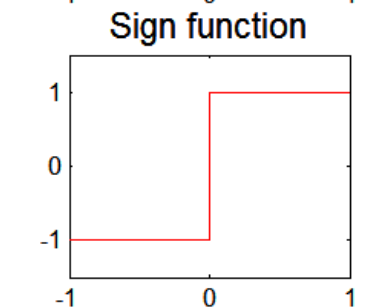
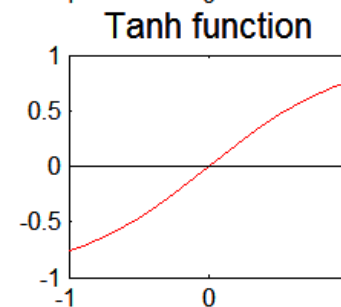
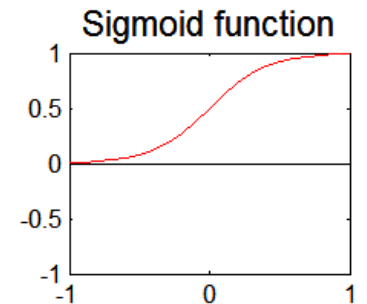
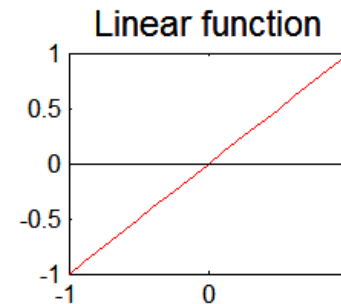

# Deep Neural Networks

---

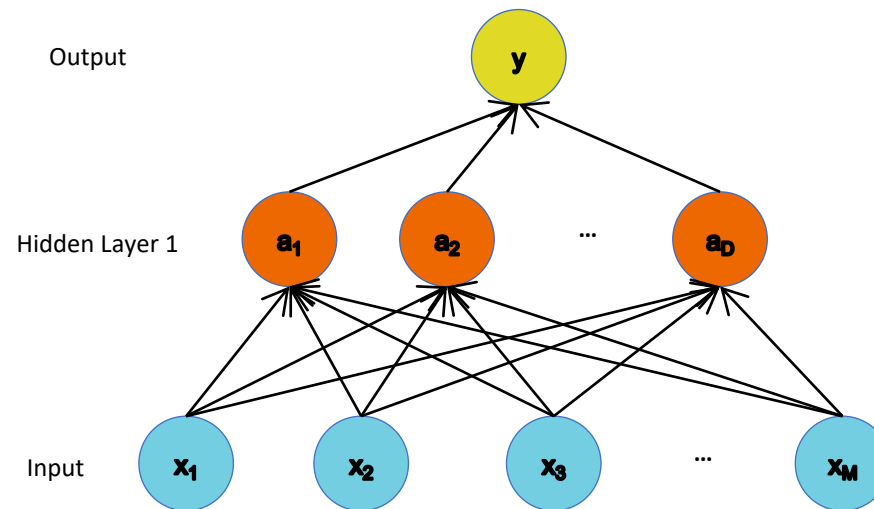

# Deep Neural Networks

---

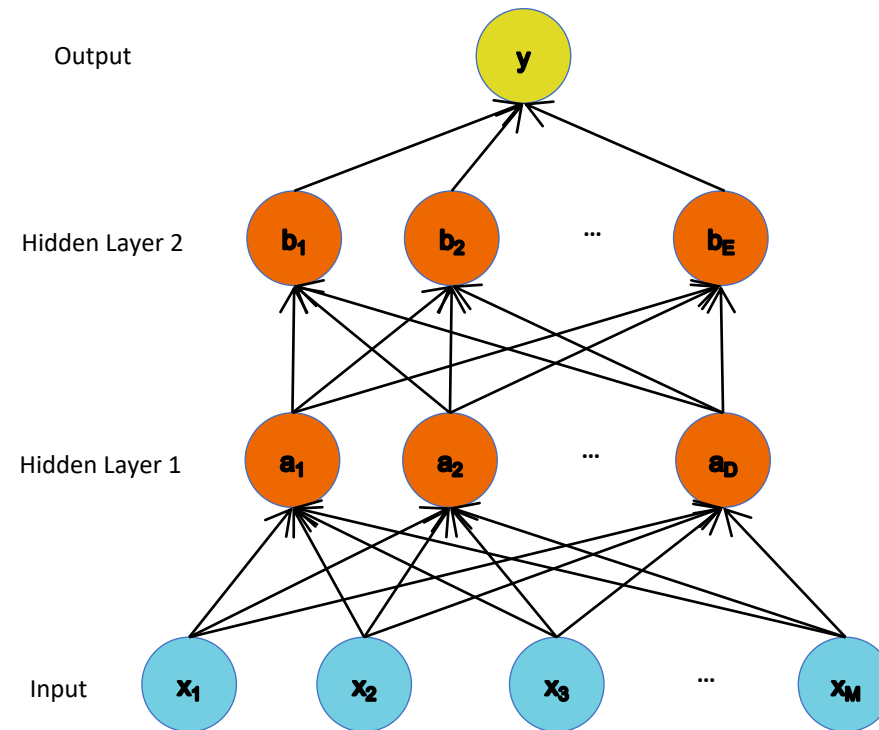

# Deep Neural Networks

Backpropagation through many layers has numerical problems that makes learning not-straightforward (Gradient Vanish/Explosion)

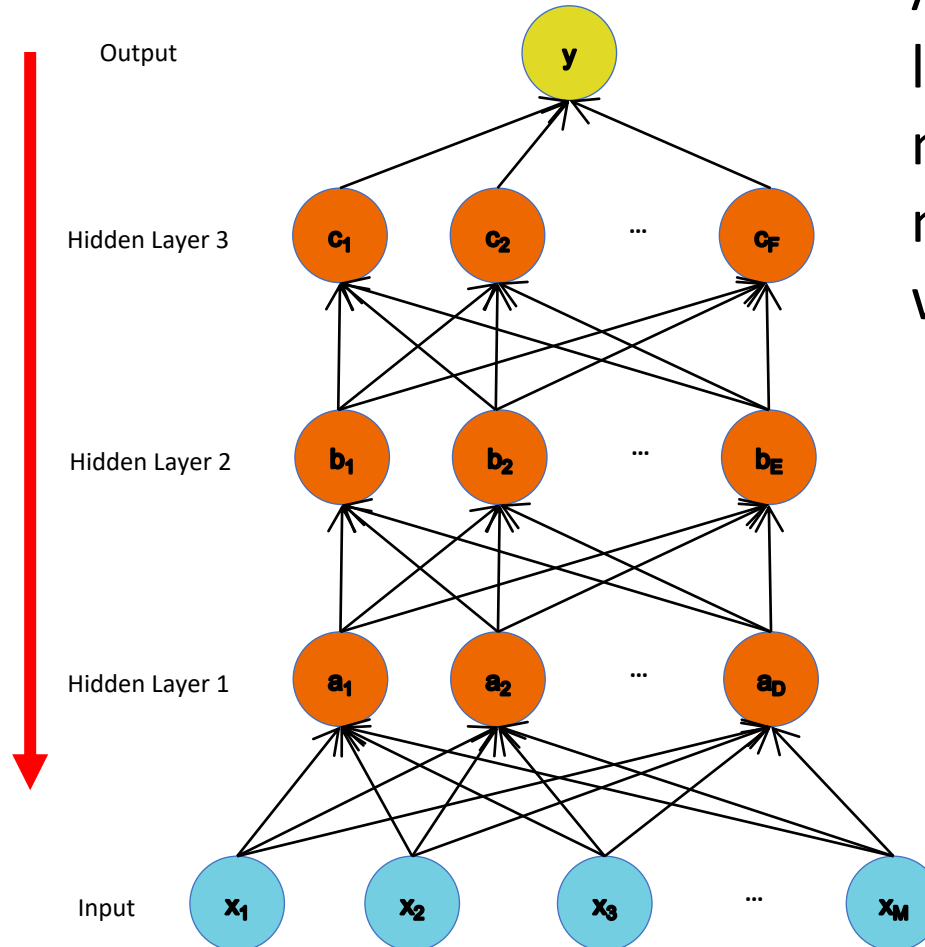

Actually deep learning is way more than having neural networks with a lot of layers

# Representation Learning

- We don't know the "right" levels of abstraction of information that is good for the machine
- So let the model figure it out!

Feature representation

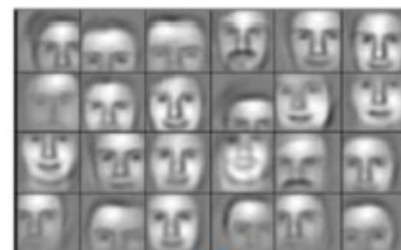

3rd layer  
"Objects"



2nd layer  
"Object parts"

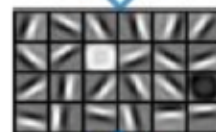

1st layer  
"Edges"



Pixels

# Representation Learning

## Face Recognition:

- Deep Network can build up increasingly higher levels of abstraction
- Lines, parts, regions

Feature representation



3rd layer  
“Objects”



2nd layer  
“Object parts”

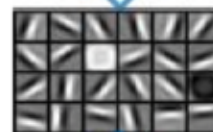

1st layer  
“Edges”



Pixels

# Representation Learning

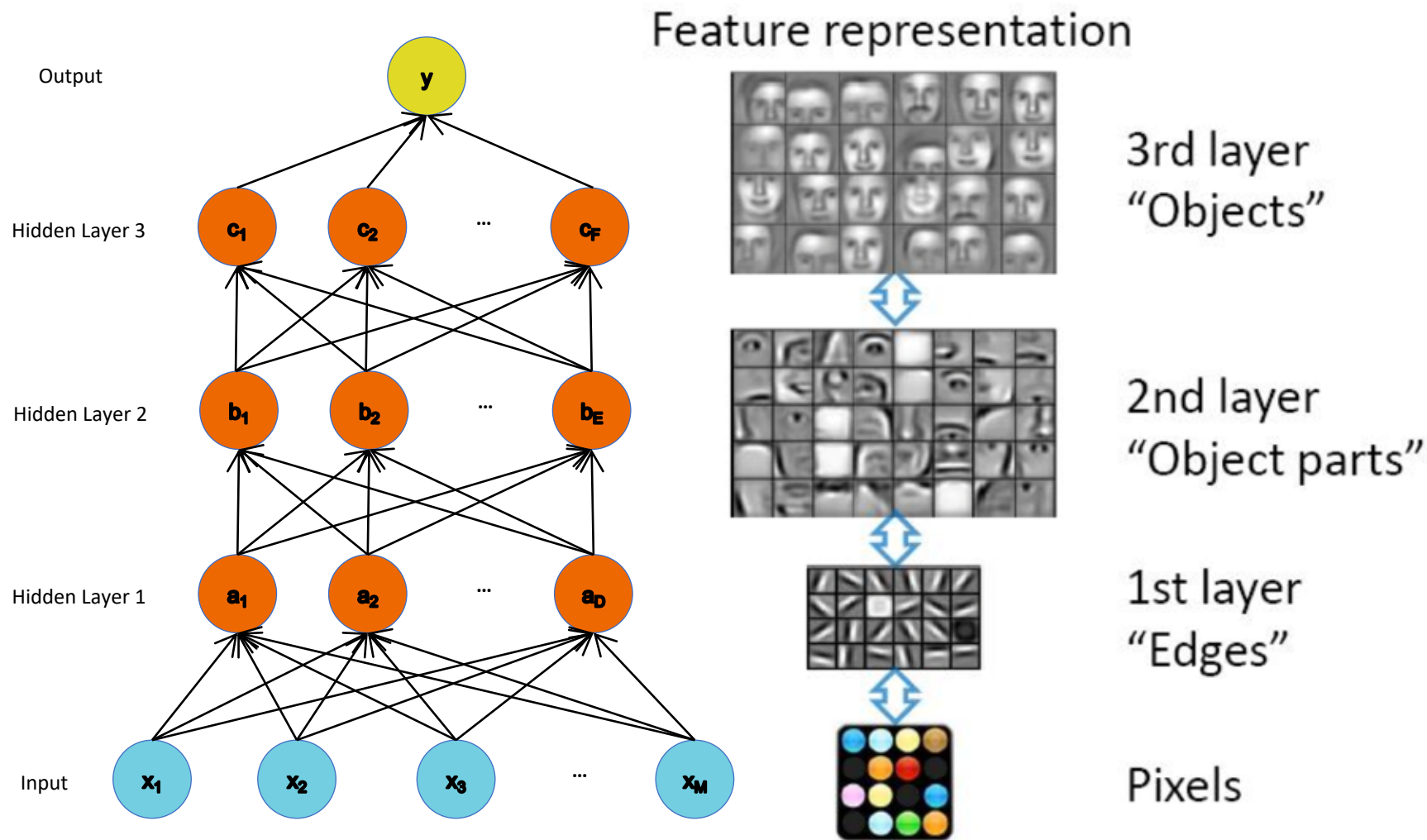

Example from Honglak Lee (NIPS 2010)

# Activation Functions

- A new change: modifying the nonlinearity
  - The logistic is not widely used in modern ANNs

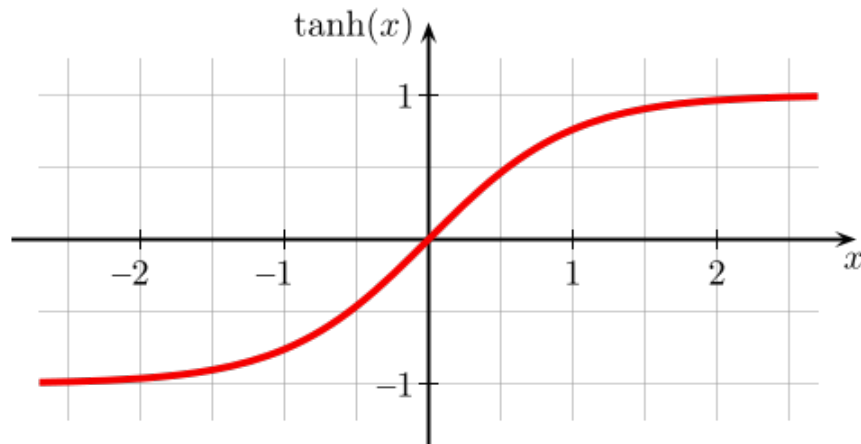

Alternative 1:  
tanh

Like logistic function but shifted  
to range  $[-1, +1]$

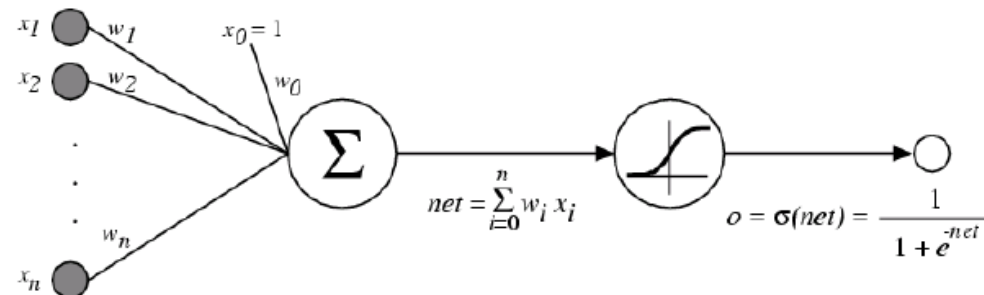



# Activation Functions

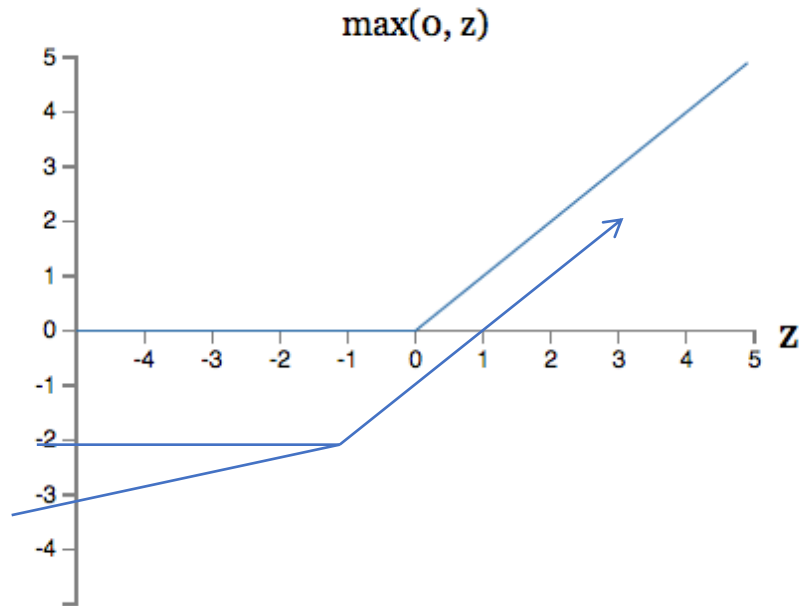

Alternative 2: rectified linear unit

Linear with a cutoff at zero

(Implementation: clip the gradient when you pass zero)

$$\max(0, w \cdot x + b).$$

# Activation Functions

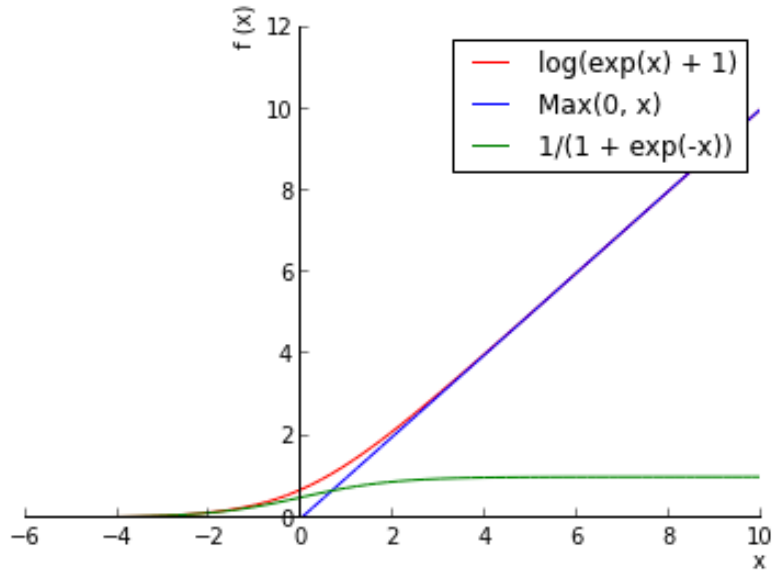

Alternative 3: soft exponential linear unit

Soft version:  $\log(\exp(x)+1)$

Doesn't saturate (at one end)

Sparsifies outputs

Helps with vanishing gradient

# Activation Functions Summary

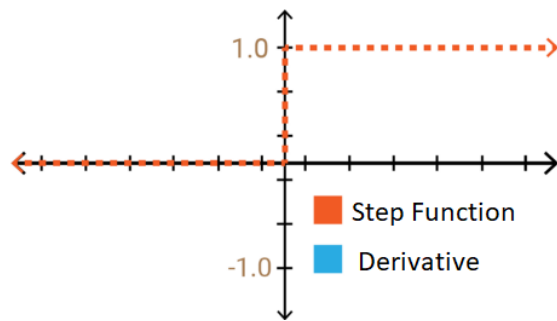

$$f(x) = \begin{cases} 0 & \text{for } x < 0 \\ 1 & \text{for } x \geq 0 \end{cases}$$

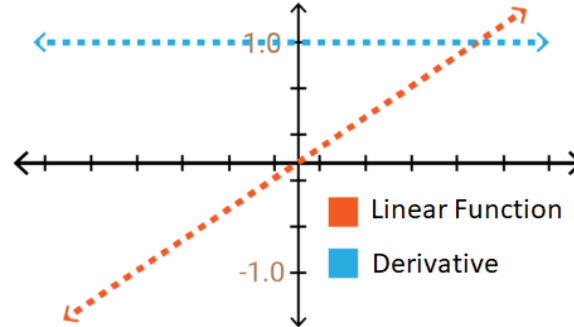

$$f(x) = x$$

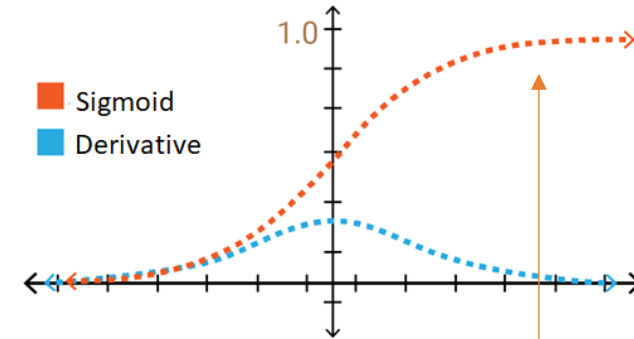

$$f(x) = \frac{1}{1 + e^{-x}}$$

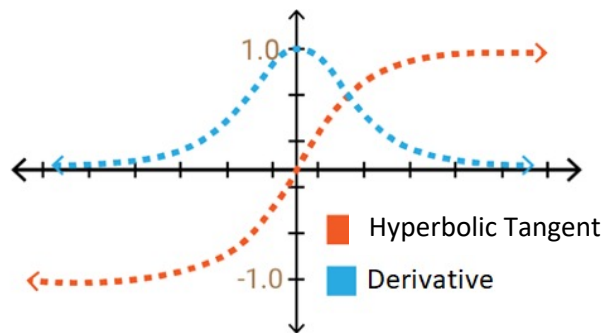

$$f(x) = \frac{e^x - e^{-x}}{e^x + e^{-x}}$$

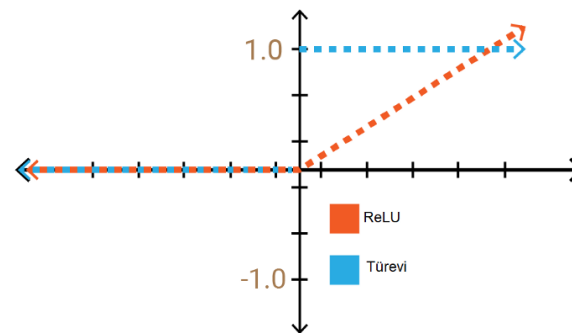

$$f(x) = \begin{cases} 0 \text{ (or } \epsilon) & \text{for } x < 0 \\ x & \text{for } x \geq 0 \end{cases}$$

$$f(x_j) = \frac{e^{x_j}}{\sum_k e^{x_k}}$$

Softmax Function

# Learning Multi-layer Neural Network

---

- Can we apply perceptron learning to each node, including hidden nodes?
- Perceptron computes error  $e = y - f(w, x)$  and updates weights accordingly
- Problem: how to determine the true value of  $y$  for hidden nodes?
- Approximate error in hidden nodes by error in the output nodes
- Problems:
  - Not clear how adjustment in the hidden nodes affect overall error
  - No guarantee of convergence to optimal solution

# Gradient Descent for Multilayer NN

Sum of Squared Residuals

- Error function to minimize:  $E = \frac{1}{2} \sum_{i=1}^N \left( y_i - f\left(\sum_j w_j x_{ij}\right) \right)^2$

Quadratic function from which we can find a global minimum solution

- Weight update:  $w_j^{(k+1)} = w_j^{(k)} - \lambda \frac{\partial E}{\partial w_j}$

Slope of the Activation Function obtained as partial derivative by the Gradient Descent

- Activation function  $f$  must be differentiable

- For sigmoid function:  $w_j^{(k+1)} = w_j^{(k)} + \lambda \sum_i (y_i - o_i) o_i (1 - o_i) x_{ij}$

Step Size

- Stochastic Gradient Descent (update the weight immediately)

# Gradient Descent for Multilayer NN

- Weights are updated in the opposite direction of the gradient of the loss function.
- Gradient direction is the direction of uphill of the error function.
- By taking the negative we are going downhill.
- Hopefully to a minimum of the error.

$$w_j^{(k+1)} = w_j^{(k)} - \lambda \frac{\partial E}{\partial w_j}$$

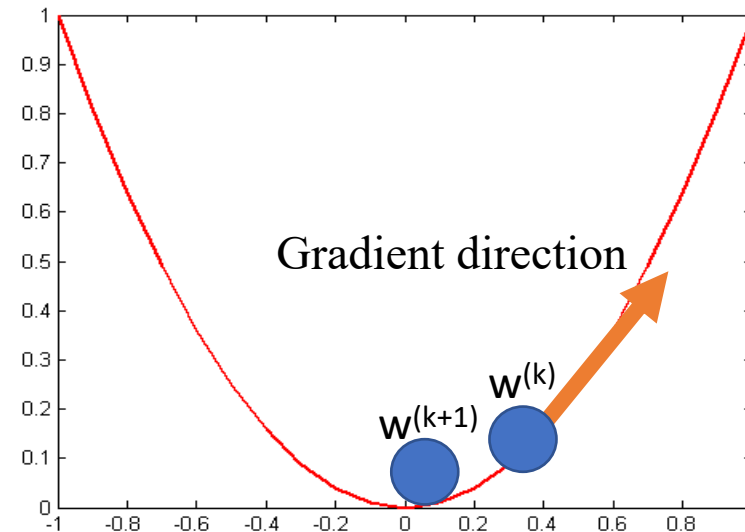

# Gradient Descent for Multilayer NN

- For output neurons, weight update formula is the same as before (gradient descent for perceptron)

- For hidden neurons:

$$w_{pi}^{(k+1)} = w_{pi}^{(k)} + \lambda o_i (1 - o_i) \sum_{j \in \Phi_i} \delta_j w_{ij} x_{pi}$$

$$\text{Output neurons : } \delta_j = o_j (1 - o_j) (t_j - o_j)$$

$$\text{Hidden neurons : } \delta_j = o_j (1 - o_j) \sum_{k \in \Phi_j} \delta_k w_{jk}$$

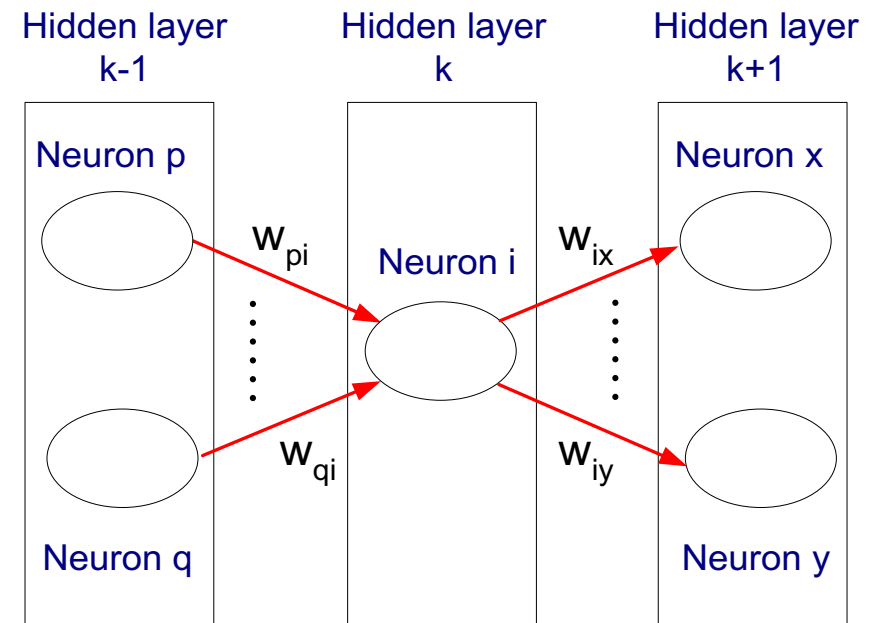

$o$ : output of the network  
 $t$ : target value (ground truth)

# Training Multilayer NN

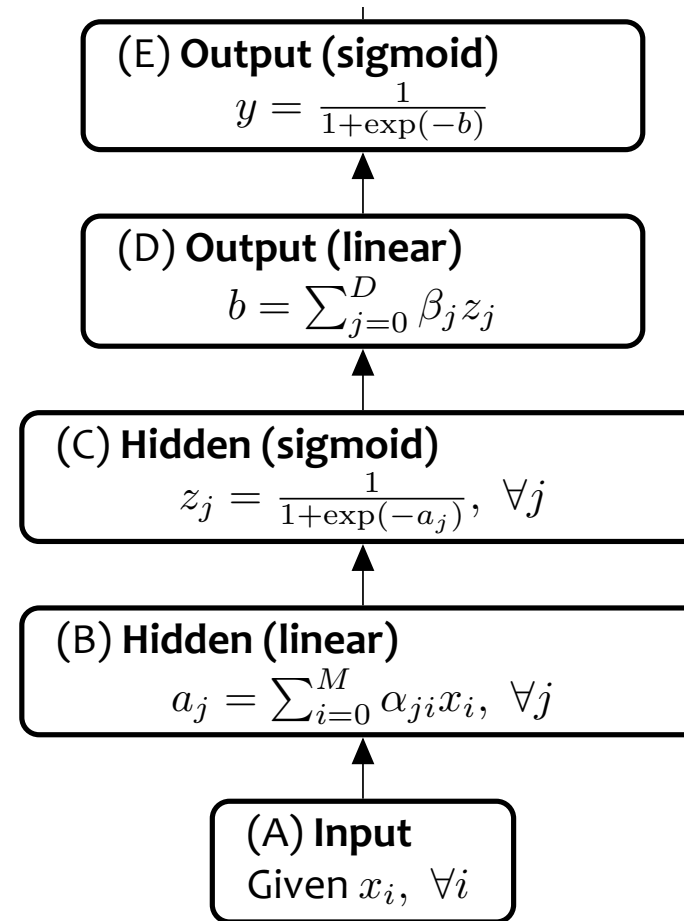
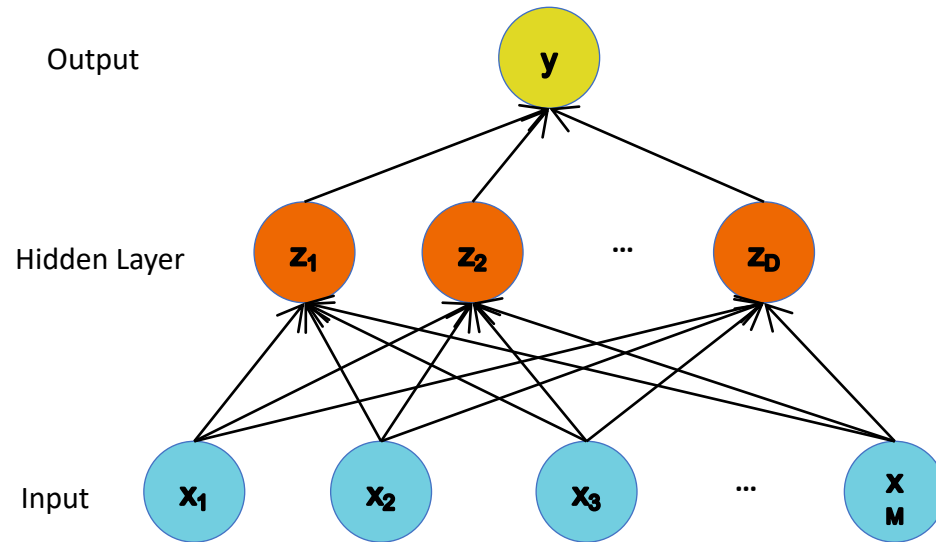



# Training Multilayer NN

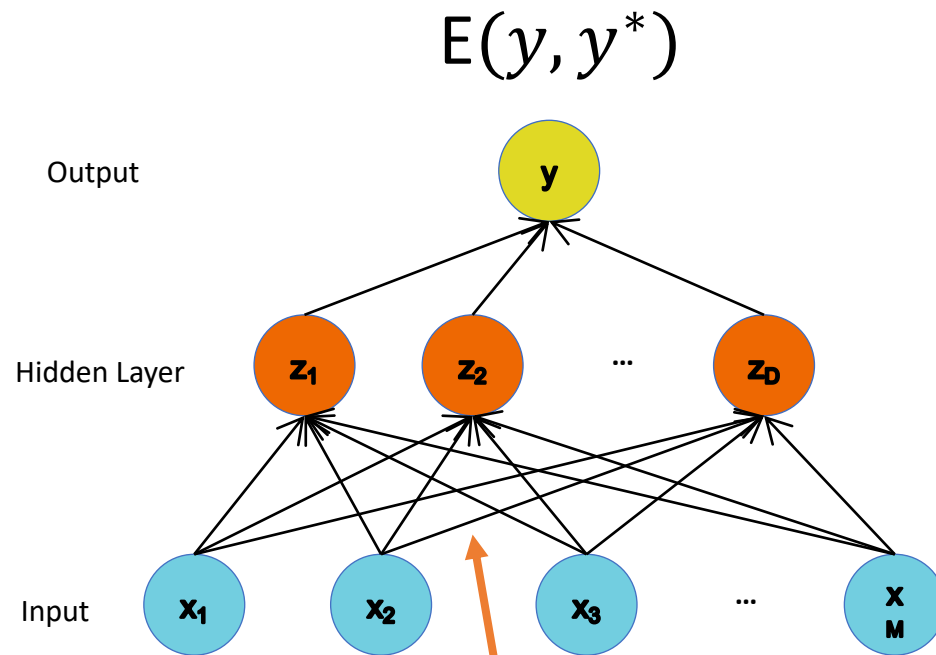

How do we update these weights given the loss is available only at the output unit?

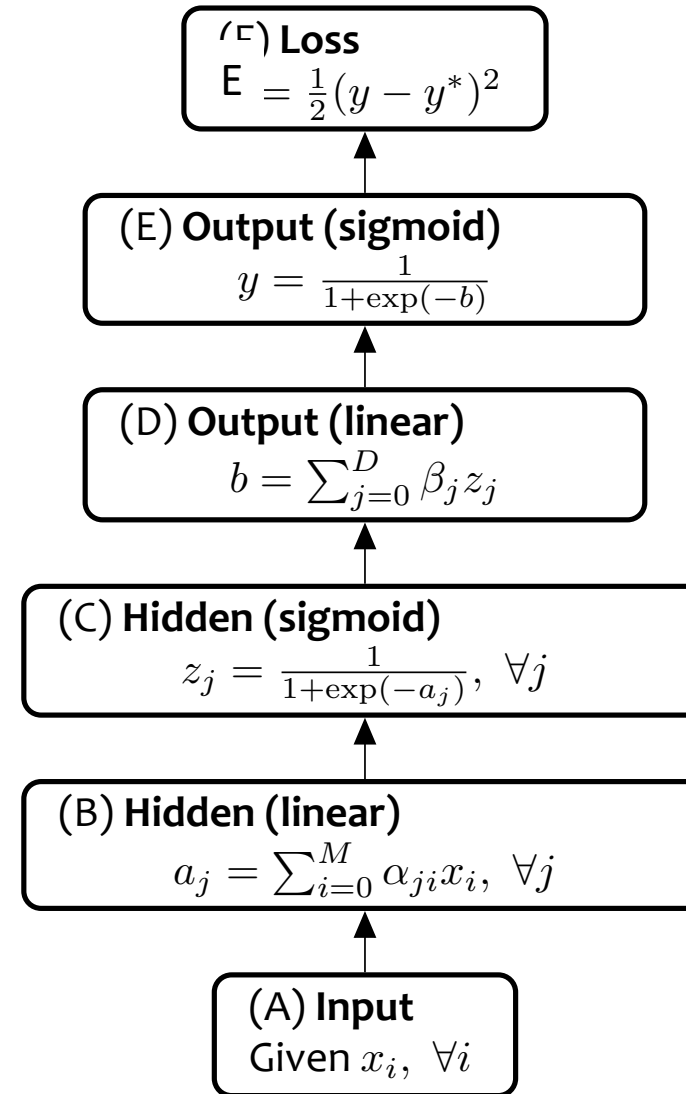

# Error Backpropagation

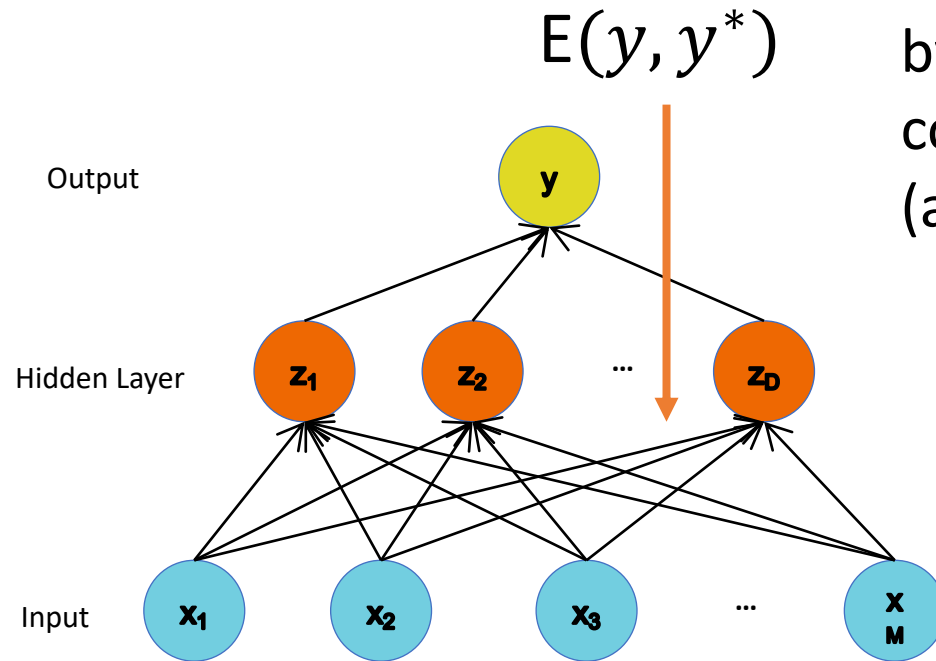

Error is computed at the output and propagated back to the input by chain rule to compute the contribution of each weight (a.k.a. derivative) to the loss

A 2-step process

1. **Forward pass** - Compute the network output
2. **Backward pass** – Compute the loss function gradients and update

# Error Backpropagation - Example

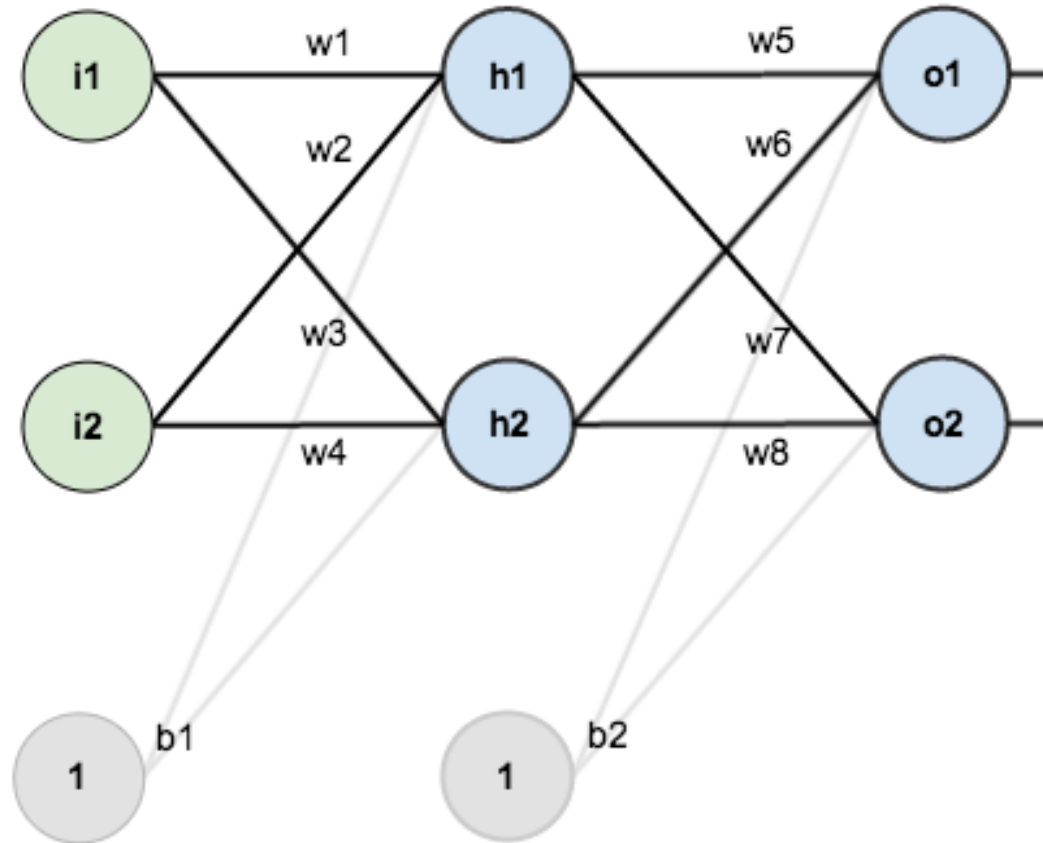

# Error Backpropagation - Example

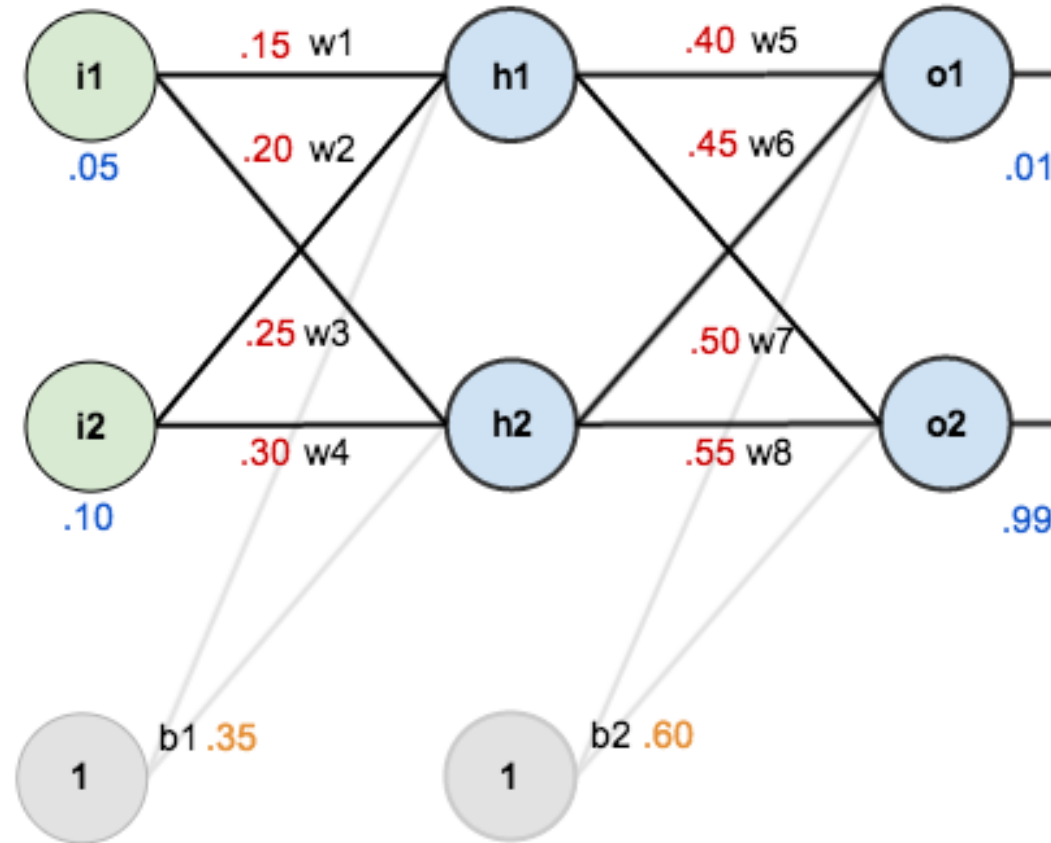

The goal of backpropagation is to optimize the weights so that the neural network can learn how to correctly map arbitrary inputs to outputs.

# Error Backpropagation - Example

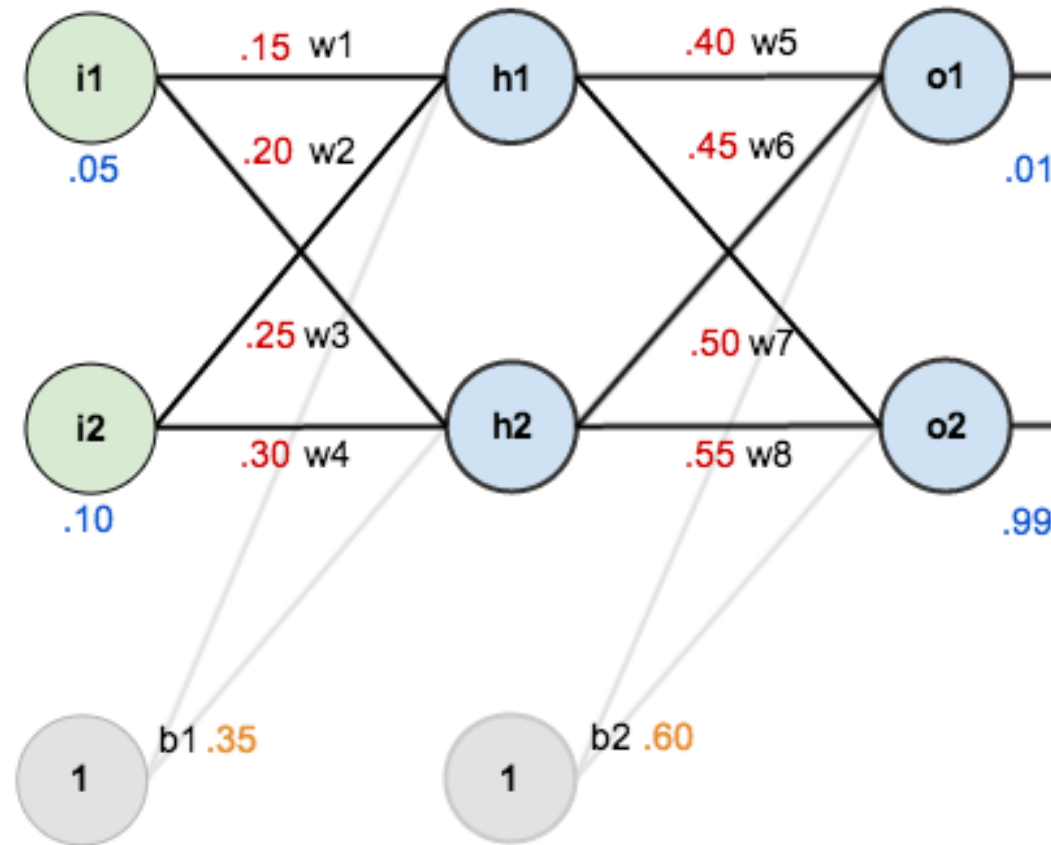

- initial weights
- biases
- training inputs/outputs
- activation: logistic

# Example - The Forward Pass →

$$net_{h1} = w_1 * i_1 + w_2 * i_2 + b_1 * 1$$

$$net_{h1} = 0.15 * 0.05 + 0.2 * 0.1 + 0.35 * 1 = 0.3775$$

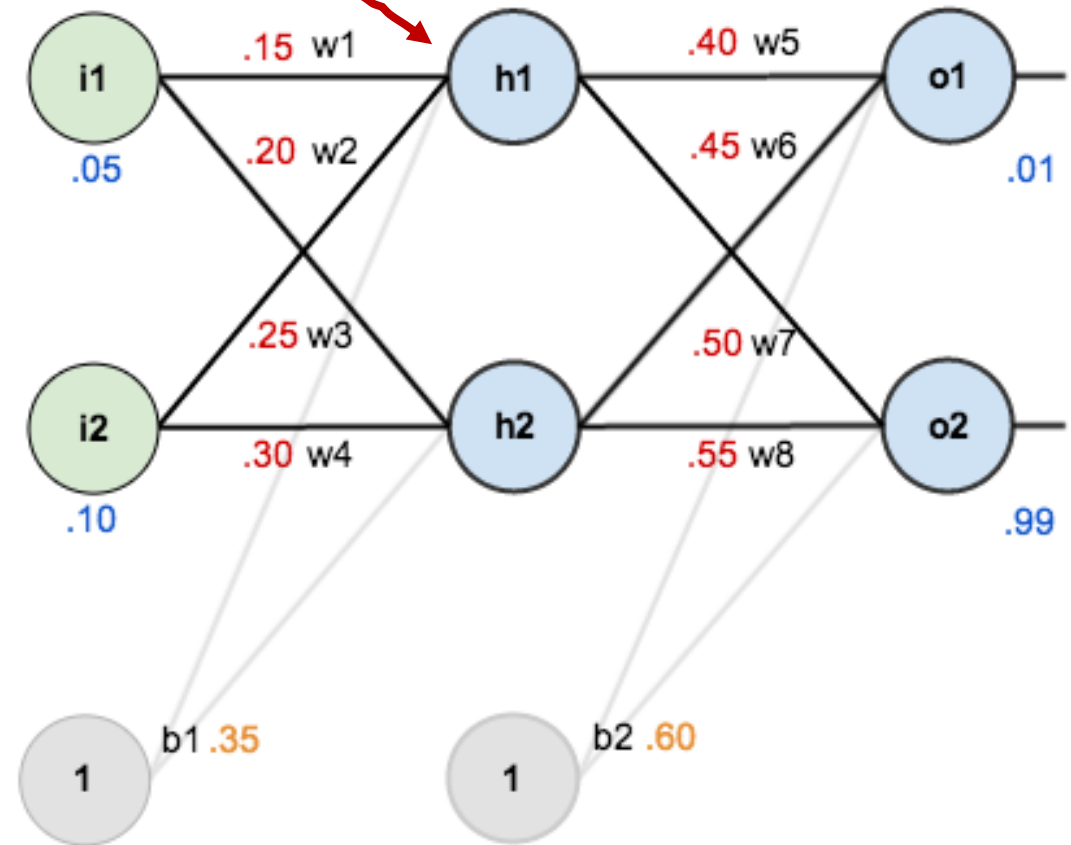

# Example - The Forward Pass →

$$net_{h1} = w_1 * i_1 + w_2 * i_2 + b_1 * 1$$

$$net_{h1} = 0.15 * 0.05 + 0.2 * 0.1 + 0.35 * 1 = 0.3775$$

$$out_{h1} = \frac{1}{1+e^{-net_{h1}}} = \frac{1}{1+e^{-0.3775}} = 0.593269992$$

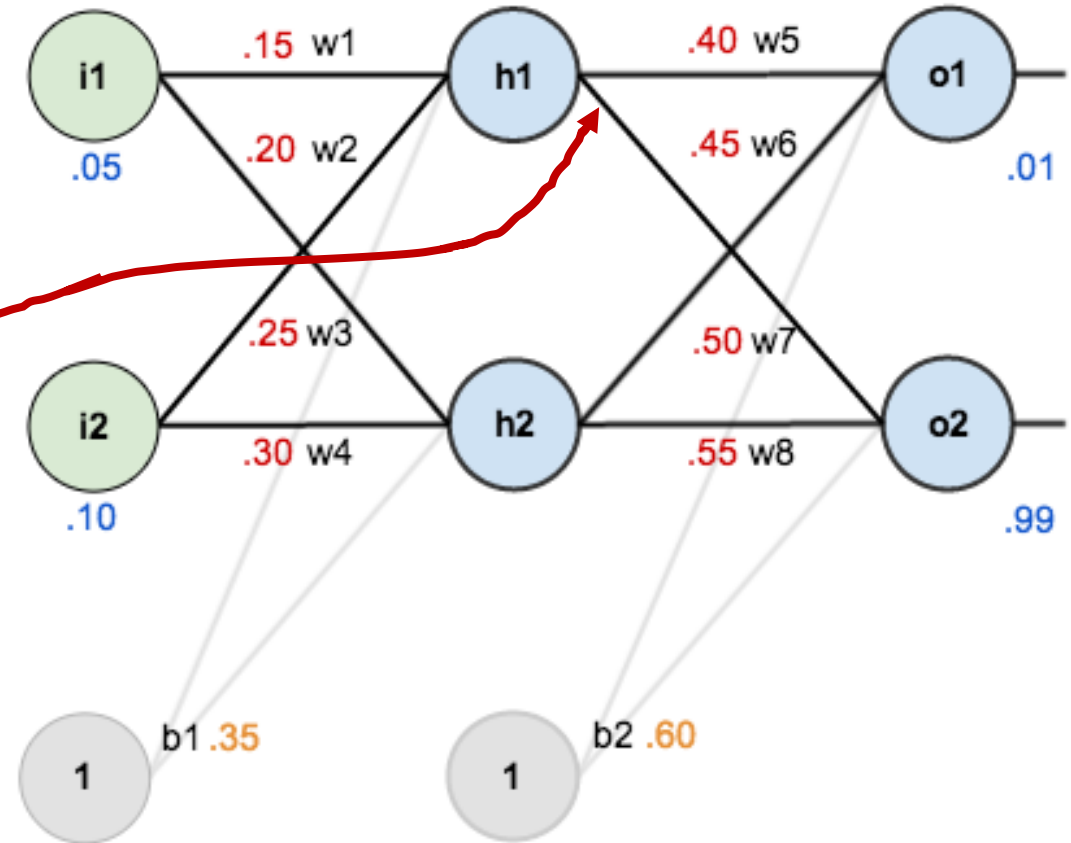

# Example - The Forward Pass →

$$net_{h1} = w_1 * i_1 + w_2 * i_2 + b_1 * 1$$

$$net_{h1} = 0.15 * 0.05 + 0.2 * 0.1 + 0.35 * 1 = 0.3775$$

$$out_{h1} = \frac{1}{1+e^{-net_{h1}}} = \frac{1}{1+e^{-0.3775}} = 0.593269992$$

$$out_{h2} = 0.596884378$$

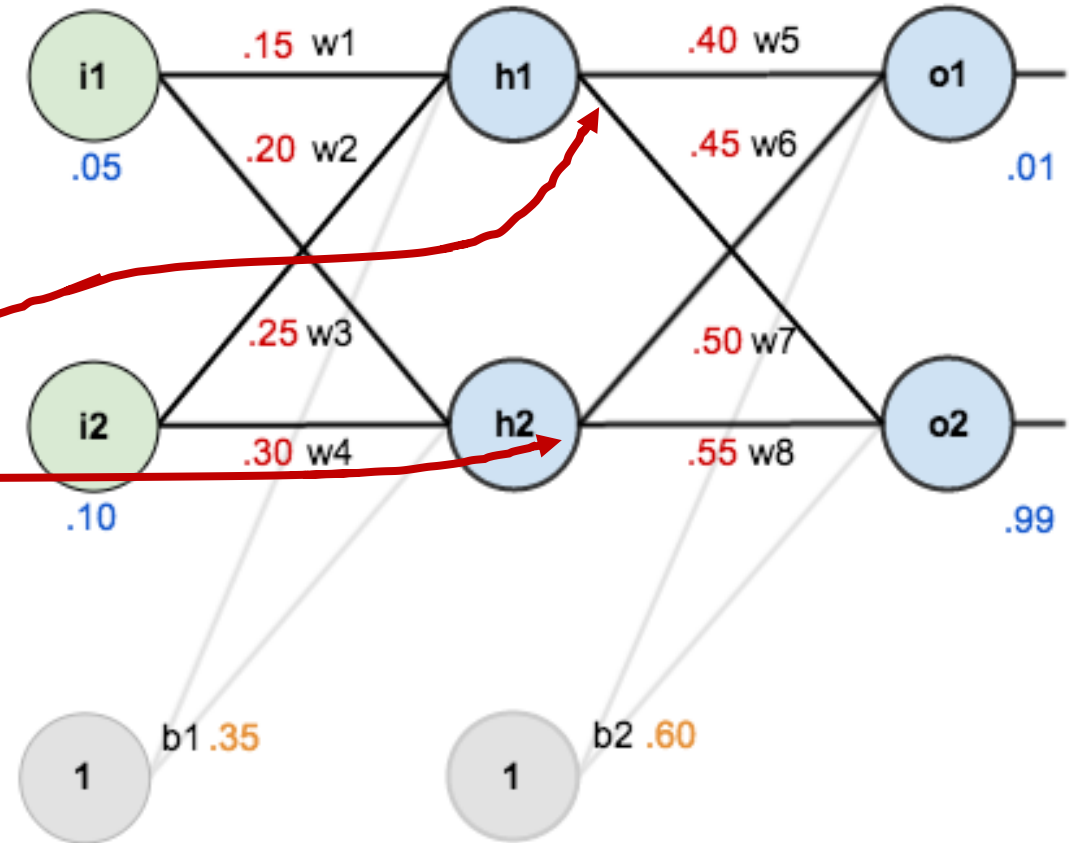



# Example - The Forward Pass →

$$net_{o1} = w_5 * out_{h1} + w_6 * out_{h2} + b_2 * 1$$

$$net_{o1} = 0.4 * 0.593269992 + 0.45 * 0.596884378 + 0.6 * 1 = 1.10$$

$$out_{o1} = \frac{1}{1+e^{-net_{o1}}} = \frac{1}{1+e^{-1.105905967}} = 0.75136507$$

$$out_{o2} = 0.772928465$$

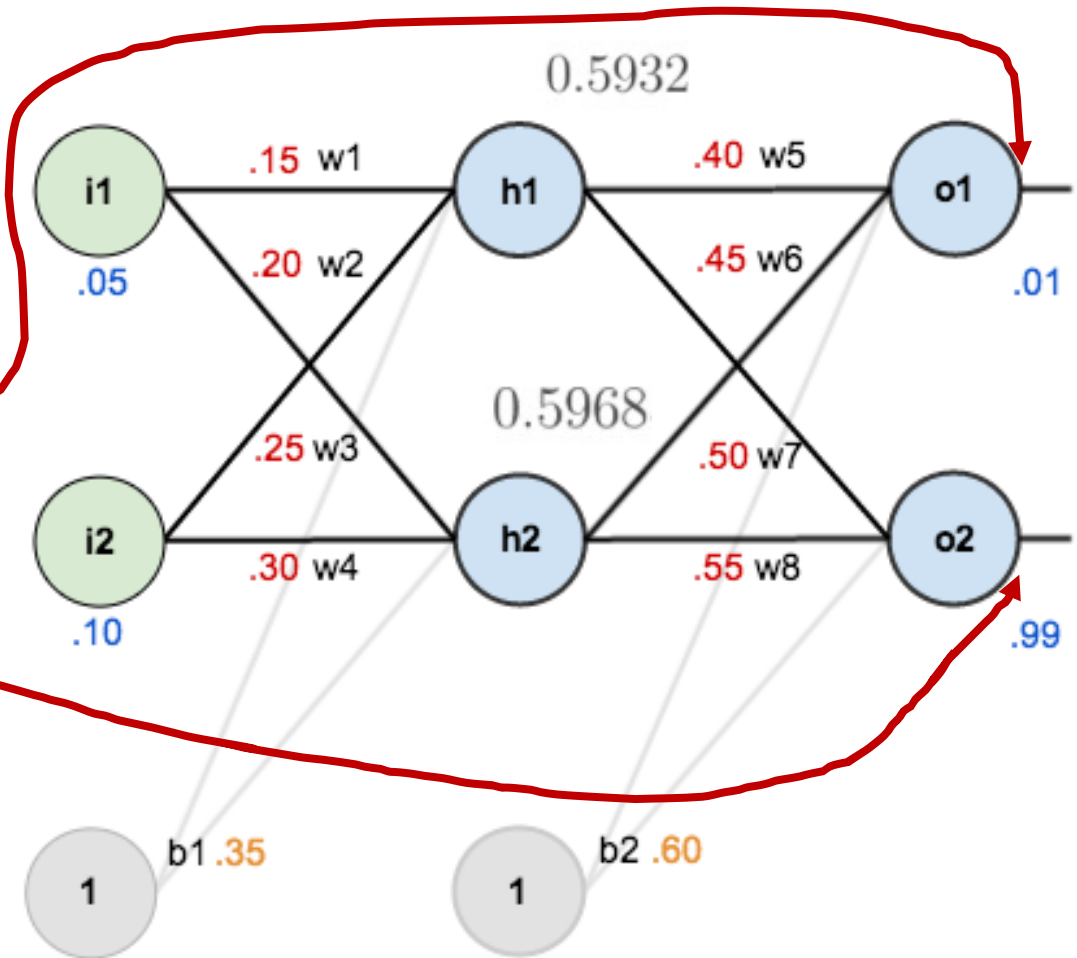

# Example – Calculating the Total Error

$$E_{total} = \sum \frac{1}{2}(target - output)^2$$

$$E_{o1} = \frac{1}{2}(target_{o1} - out_{o1})^2 = \frac{1}{2}(0.01 - 0.75136507)^2 = 0.274811083$$

$$E_{o2} = 0.023560026$$

$$E_{total} = E_{o1} + E_{o2} = 0.274811083 + 0.023560026 = 0.298371109$$

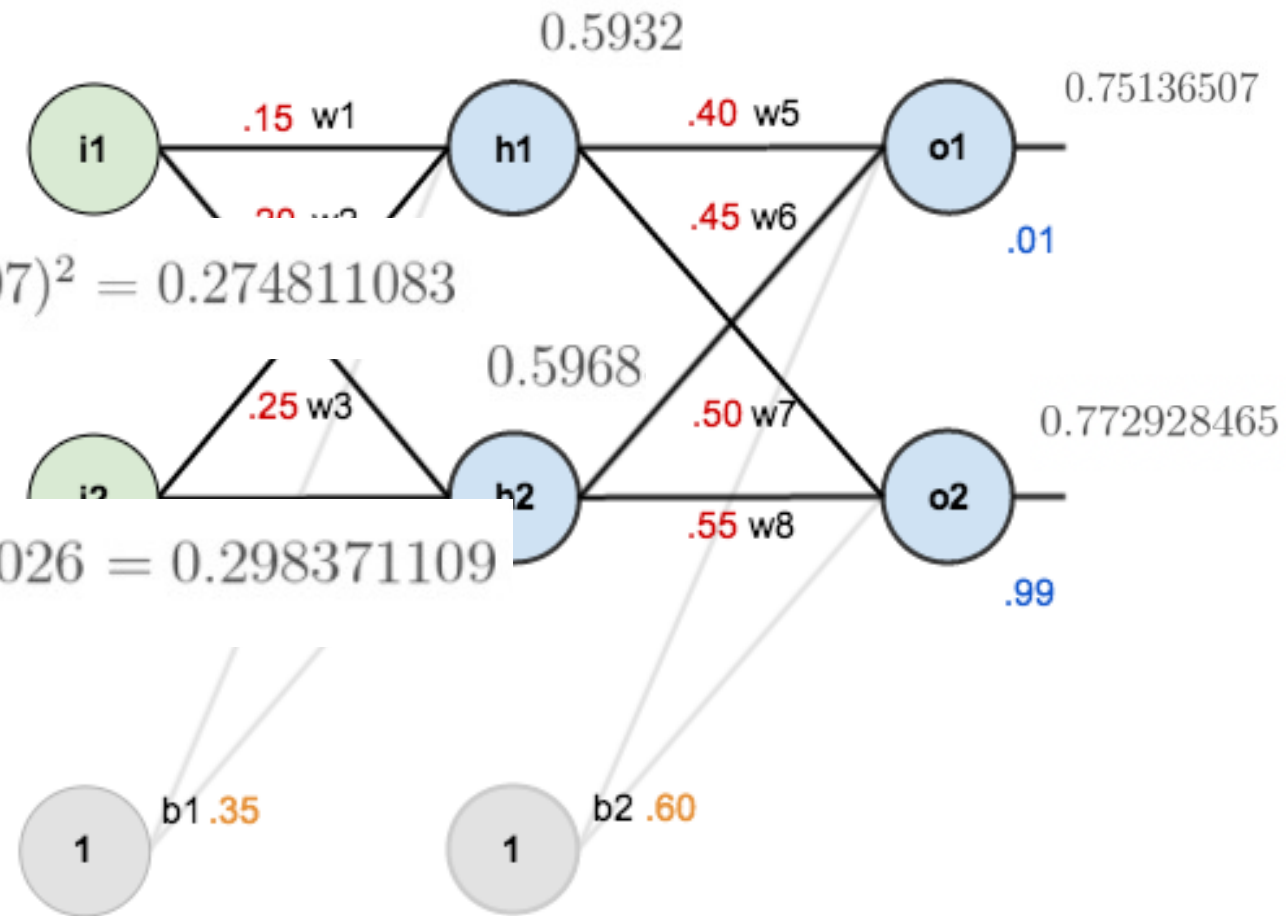

# Example - The Backward Pass ←

How much a change in  $w_5$  affects the total error?

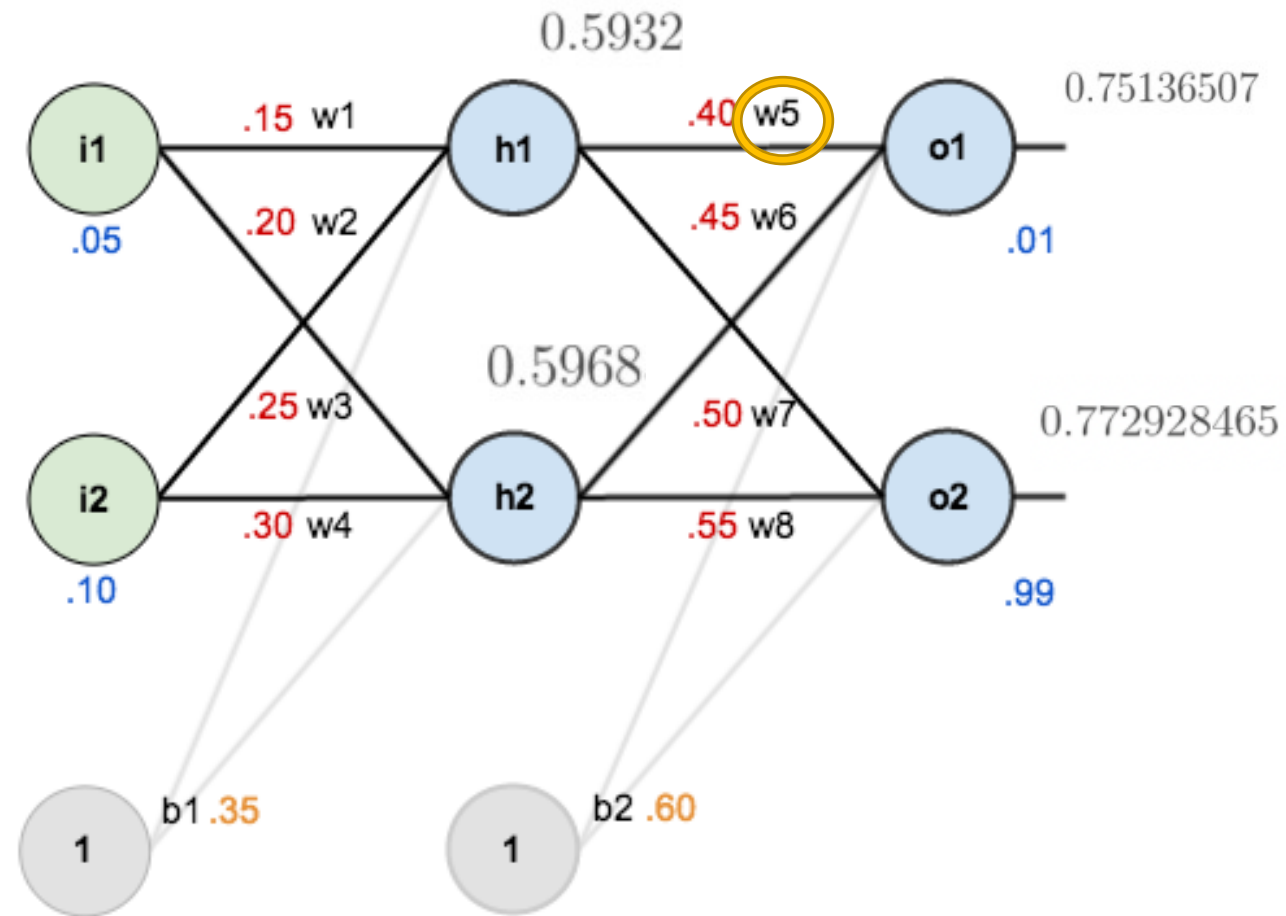

# Example - The Backward Pass ←

$$\frac{\partial E_{total}}{\partial w_5} = \frac{\partial E_{total}}{\partial out_{o1}} * \frac{\partial out_{o1}}{\partial net_{o1}} * \frac{\partial net_{o1}}{\partial w_5}$$

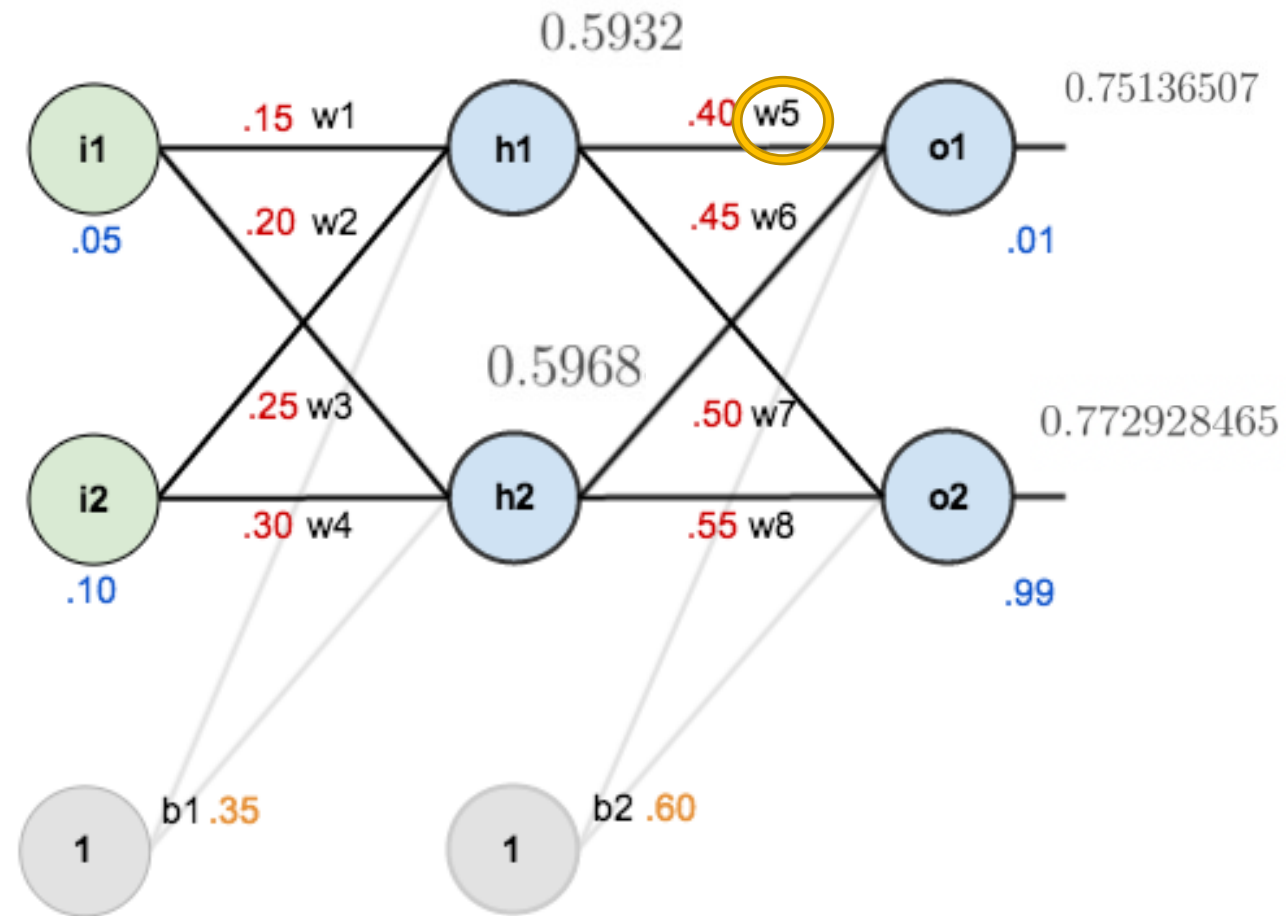

# Example - The Backward Pass ←

$$\frac{\partial E_{total}}{\partial w_5} = \frac{\partial E_{total}}{\partial out_{o1}} * \frac{\partial out_{o1}}{\partial net_{o1}} * \frac{\partial net_{o1}}{\partial w_5}$$

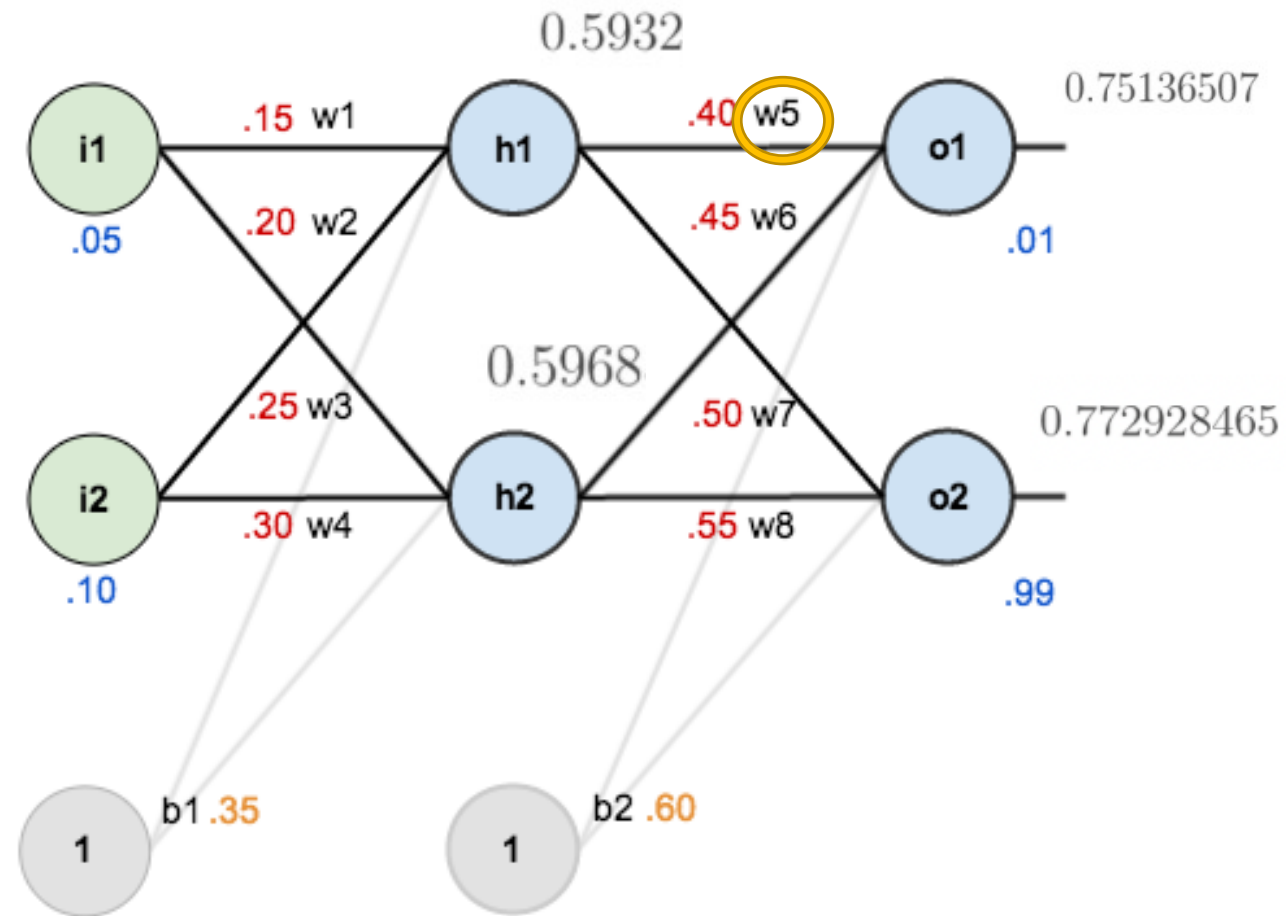
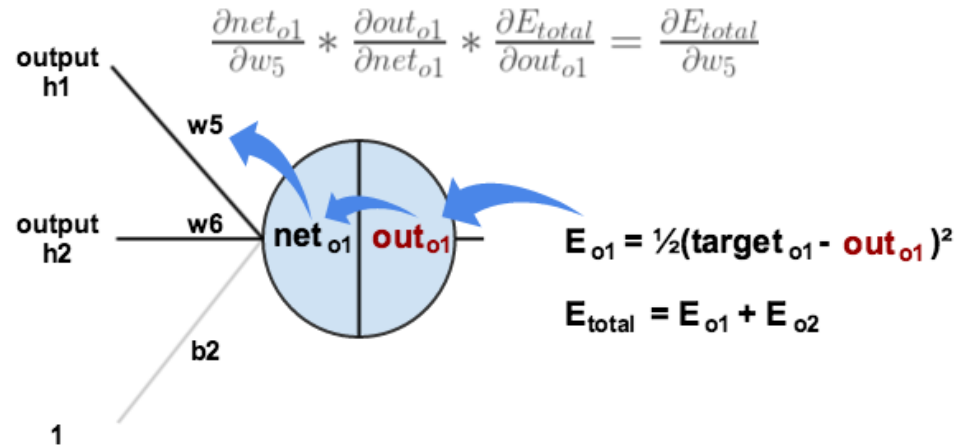

# Example - The Backward Pass ←

$$\frac{\partial E_{total}}{\partial w_5} = \frac{\partial E_{total}}{\partial out_{o1}} * \frac{\partial out_{o1}}{\partial net_{o1}} * \frac{\partial net_{o1}}{\partial w_5}$$

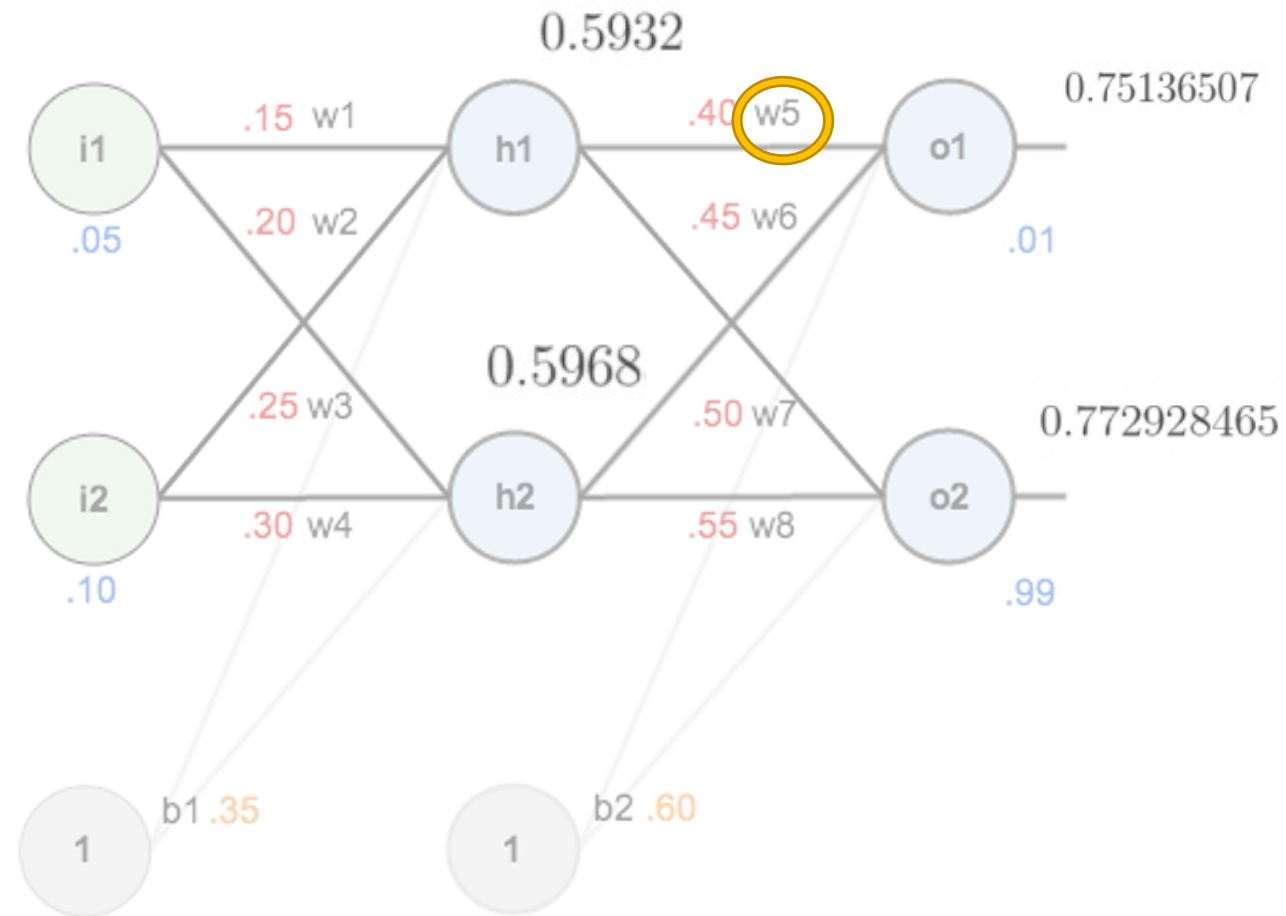

how much does the total error change with respect to the output?

# Example - The Backward Pass ←

$$\frac{\partial E_{total}}{\partial w_5} = \frac{\partial E_{total}}{\partial out_{o1}} * \frac{\partial out_{o1}}{\partial net_{o1}} * \frac{\partial net_{o1}}{\partial w_5}$$

$$E_{total} = \frac{1}{2}(target_{o1} - out_{o1})^2 + \frac{1}{2}(target_{o2} - out_{o2})^2$$

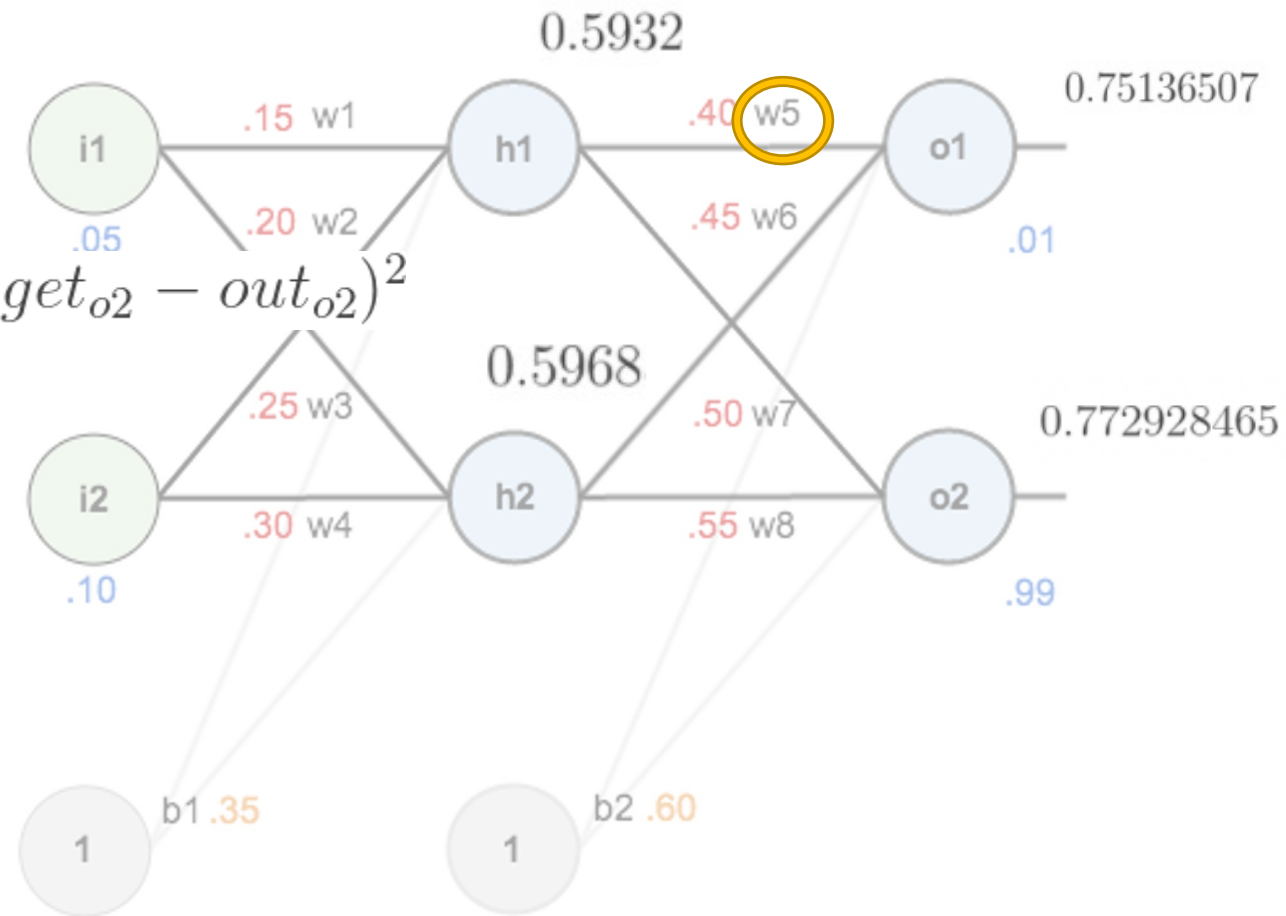

how much does the total error change with respect to the output?

# Example - The Backward Pass ←

$$\frac{\partial E_{total}}{\partial w_5} = \frac{\partial E_{total}}{\partial out_{o1}} * \frac{\partial out_{o1}}{\partial net_{o1}} * \frac{\partial net_{o1}}{\partial w_5}$$

$$E_{total} = \frac{1}{2}(target_{o1} - out_{o1})^2 + \frac{1}{2}(target_{o2} - out_{o2})^2$$

$$\frac{\partial E_{total}}{\partial out_{o1}} = 2 * \frac{1}{2}(target_{o1} - out_{o1})^{2-1} * -1 + 0$$

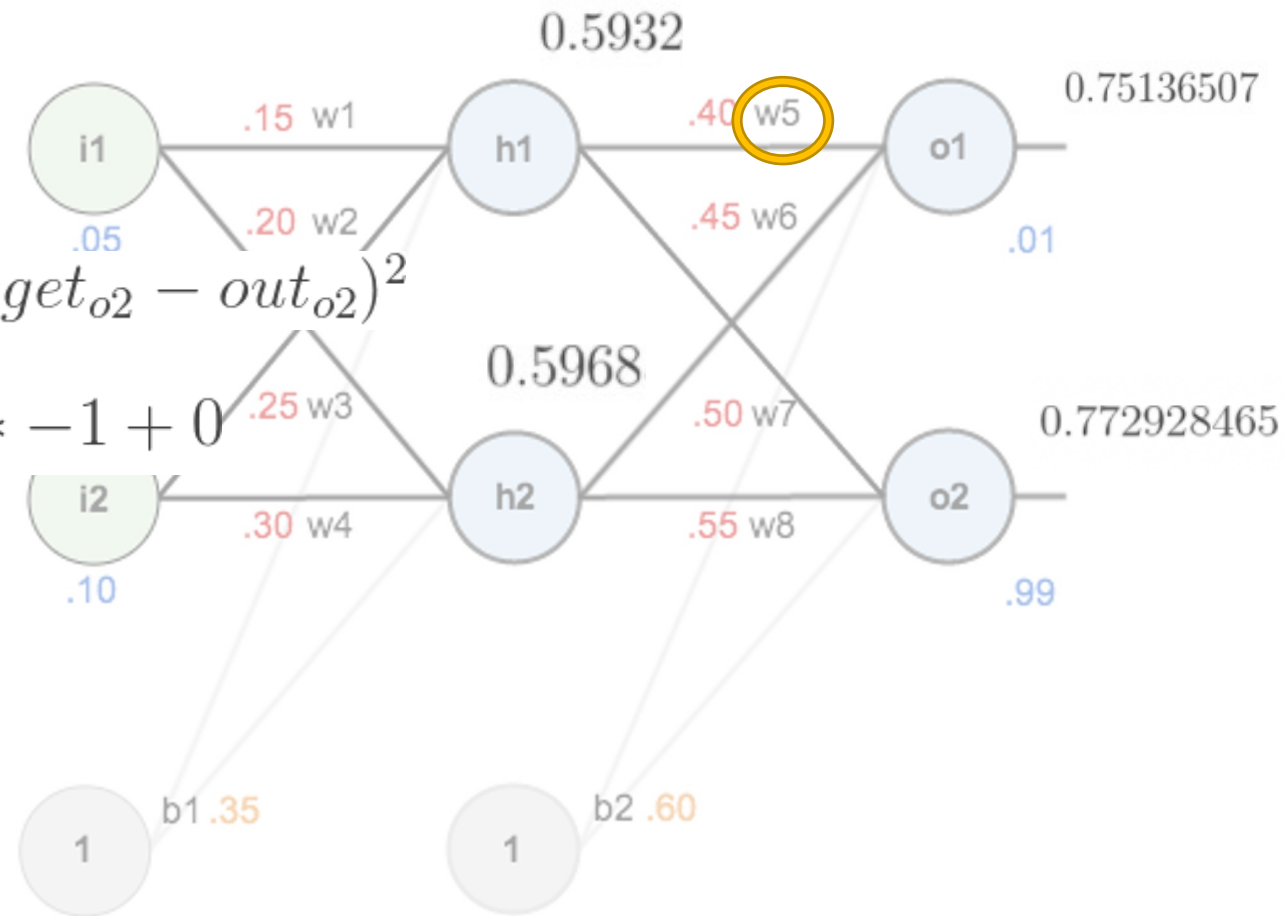

how much does the total error change with respect to the output?



# Example - The Backward Pass ←

$$\frac{\partial E_{total}}{\partial w_5} = \frac{\partial E_{total}}{\partial out_{o1}} * \frac{\partial out_{o1}}{\partial net_{o1}} * \frac{\partial net_{o1}}{\partial w_5}$$

$$E_{total} = \frac{1}{2}(target_{o1} - out_{o1})^2 + \frac{1}{2}(target_{o2} - out_{o2})^2$$

$$\frac{\partial E_{total}}{\partial out_{o1}} = 2 * \frac{1}{2}(target_{o1} - out_{o1})^{2-1} * -1 + 0$$

$$\frac{\partial E_{total}}{\partial out_{o1}} = -(target_{o1} - out_{o1}) = -(0.01 - 0.75136507) = 0.74136507$$

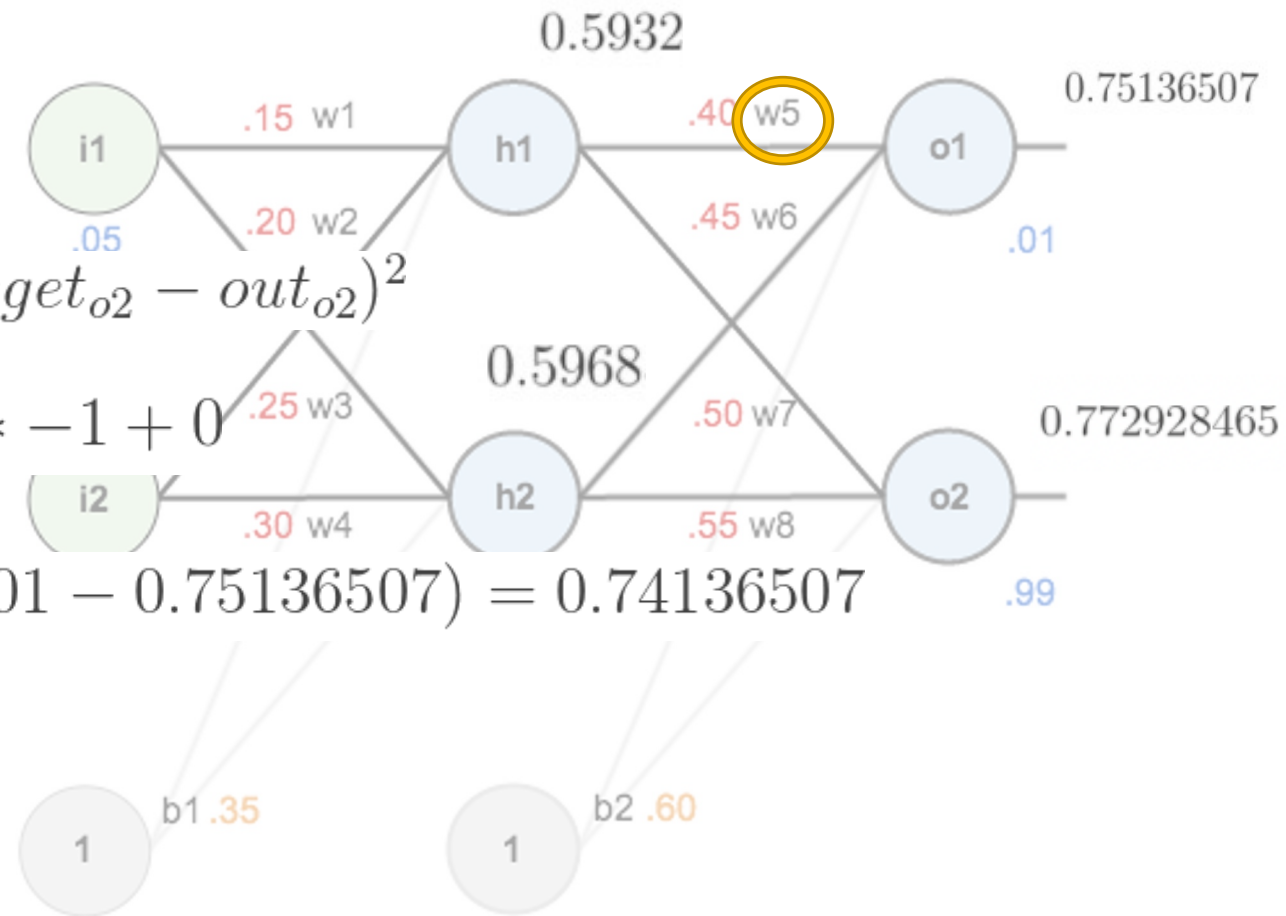

how much does the total error change with respect to the output?

# Example - The Backward Pass ←

$$\frac{\partial E_{total}}{\partial w_5} = \frac{\partial E_{total}}{\partial out_{o1}} * \frac{\partial out_{o1}}{\partial net_{o1}} * \frac{\partial net_{o1}}{\partial w_5}$$

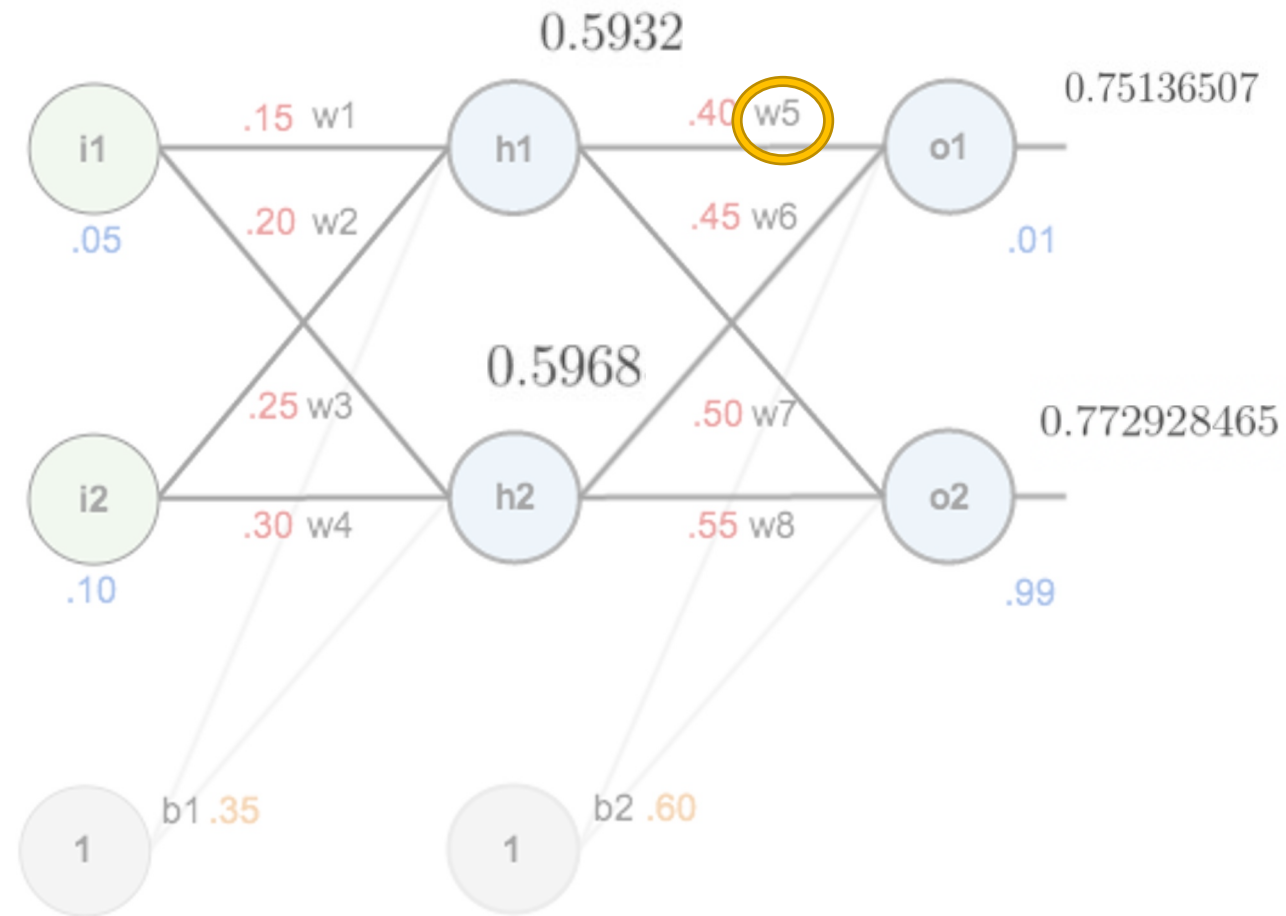

how much does the output o1 change with respect to its total net input?

# Example - The Backward Pass ←

$$\frac{\partial E_{total}}{\partial w_5} = \frac{\partial E_{total}}{\partial out_{o1}} * \frac{\partial out_{o1}}{\partial net_{o1}} * \frac{\partial net_{o1}}{\partial w_5}$$

$$out_{o1} = \frac{1}{1 + e^{-net_{o1}}}$$

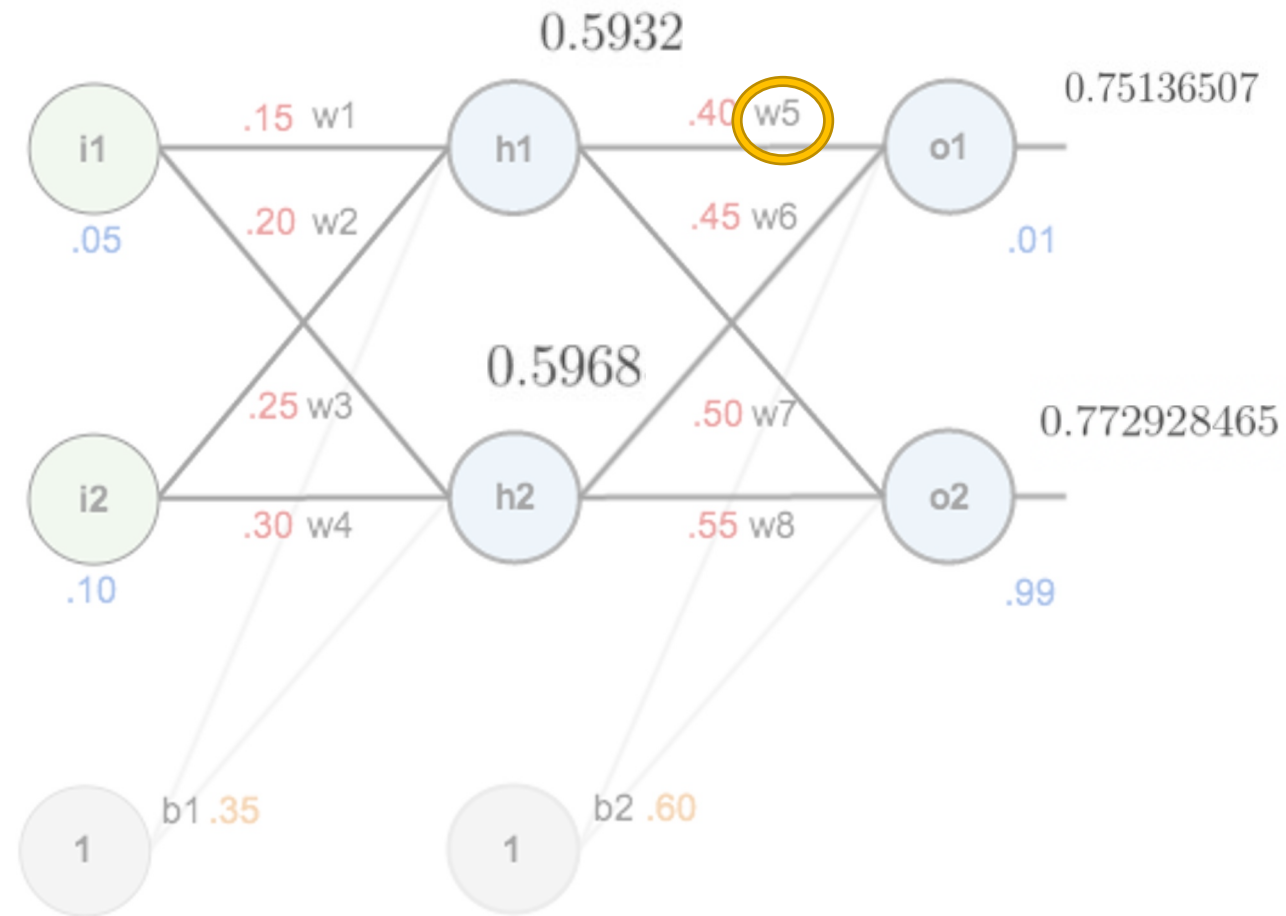

how much does the output o1 change with respect to its total net input?

# Example - The Backward Pass ←

$$\frac{\partial E_{total}}{\partial w_5} = \frac{\partial E_{total}}{\partial out_{o1}} * \frac{\partial out_{o1}}{\partial net_{o1}} * \frac{\partial net_{o1}}{\partial w_5}$$

$$out_{o1} = \frac{1}{1 + e^{-net_{o1}}}$$

$$\frac{\partial out_{o1}}{\partial net_{o1}} = out_{o1}(1 - out_{o1}) = 0.75136507(1 - 0.75136507) = 0.186815602$$

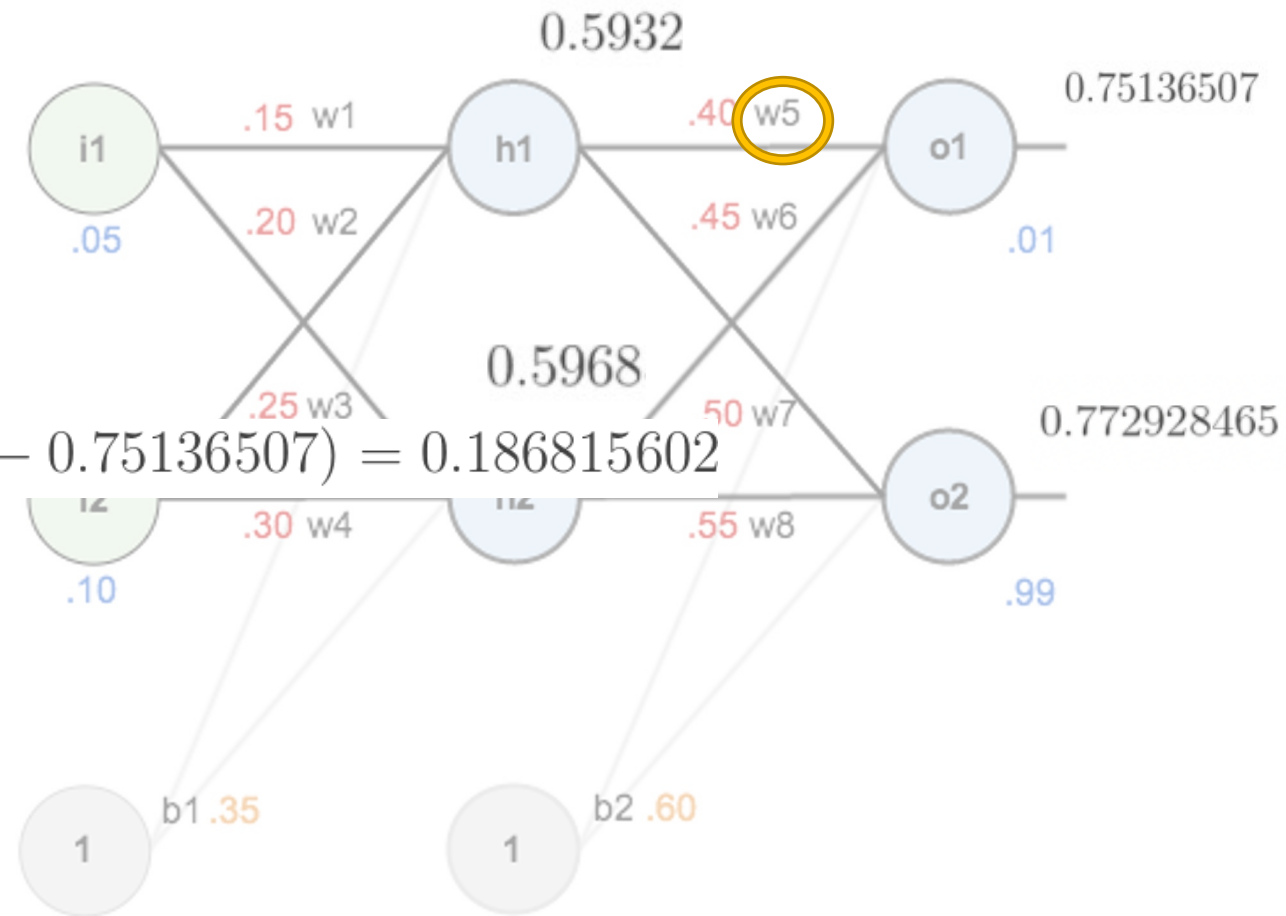

how much does the output o1 change with respect to its total net input?

# Example - The Backward Pass ←

$$\frac{\partial E_{total}}{\partial w_5} = \frac{\partial E_{total}}{\partial out_{o1}} * \frac{\partial out_{o1}}{\partial net_{o1}} * \frac{\partial net_{o1}}{\partial w_5}$$

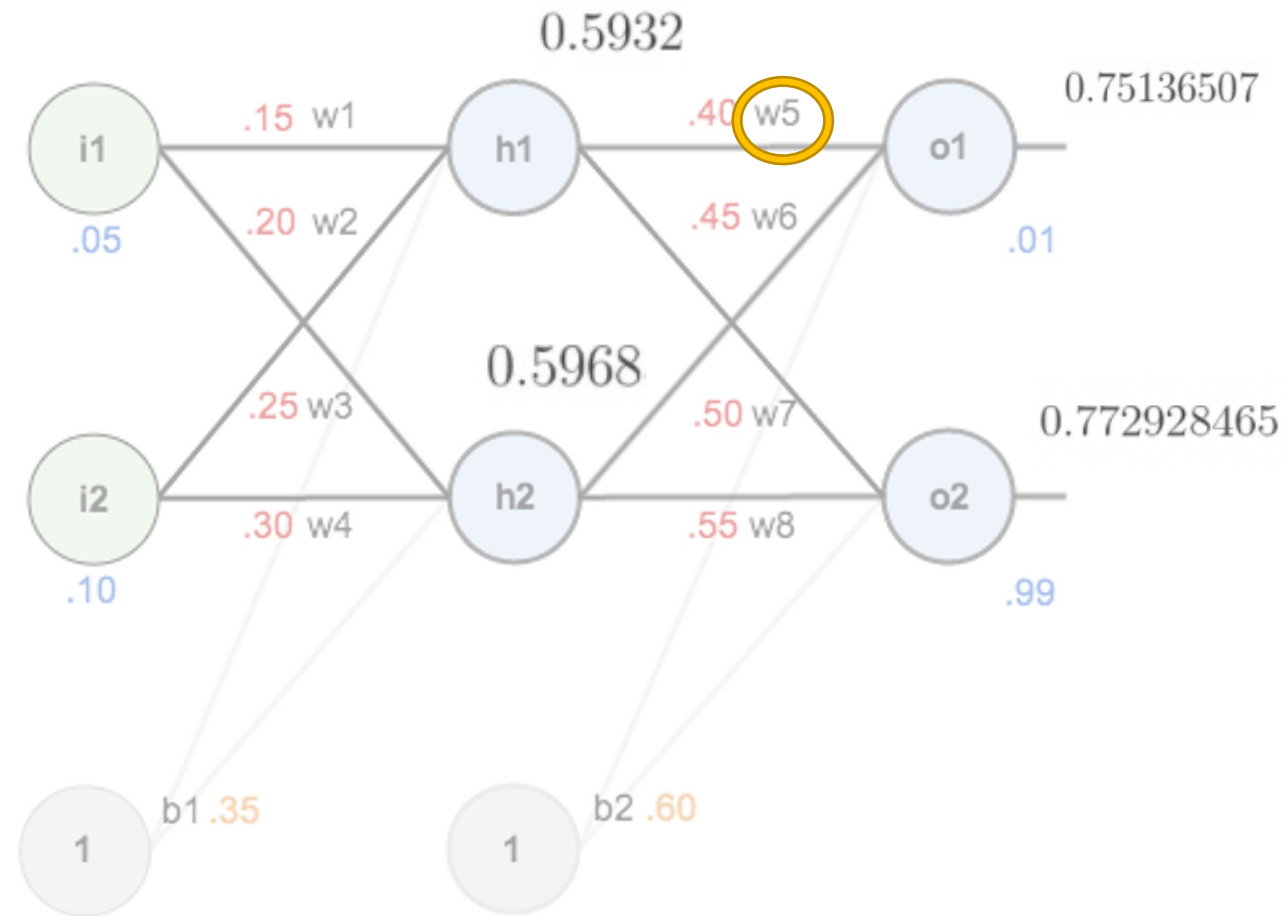

how much does the total net input of o1 change with respect to w5?

# Example - The Backward Pass ←

$$\frac{\partial E_{total}}{\partial w_5} = \frac{\partial E_{total}}{\partial out_{o1}} * \frac{\partial out_{o1}}{\partial net_{o1}} * \frac{\partial net_{o1}}{\partial w_5}$$

$$net_{o1} = w_5 * out_{h1} + w_6 * out_{h2} + b_2 * 1$$

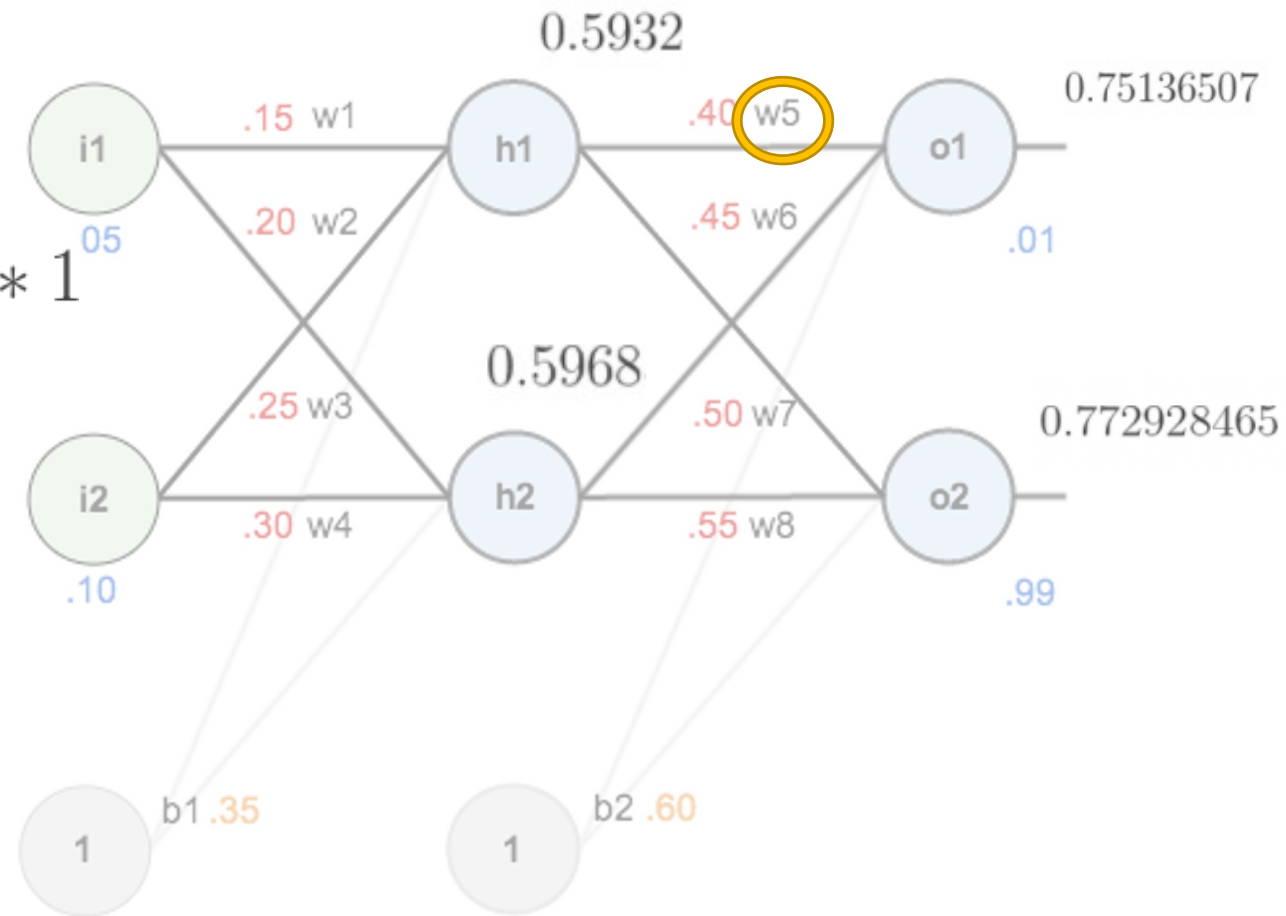

how much does the total net input of o1 change with respect to w5?

# Example - The Backward Pass ←

$$\frac{\partial E_{total}}{\partial w_5} = \frac{\partial E_{total}}{\partial out_{o1}} * \frac{\partial out_{o1}}{\partial net_{o1}} * \frac{\partial net_{o1}}{\partial w_5}$$

$$net_{o1} = w_5 * out_{h1} + w_6 * out_{h2} + b_2 * 1$$

$$\frac{\partial net_{o1}}{\partial w_5} = 1 * out_{h1} * w_5^{(1-1)} + 0 + 0 = out_{h1} = 0.593269992$$

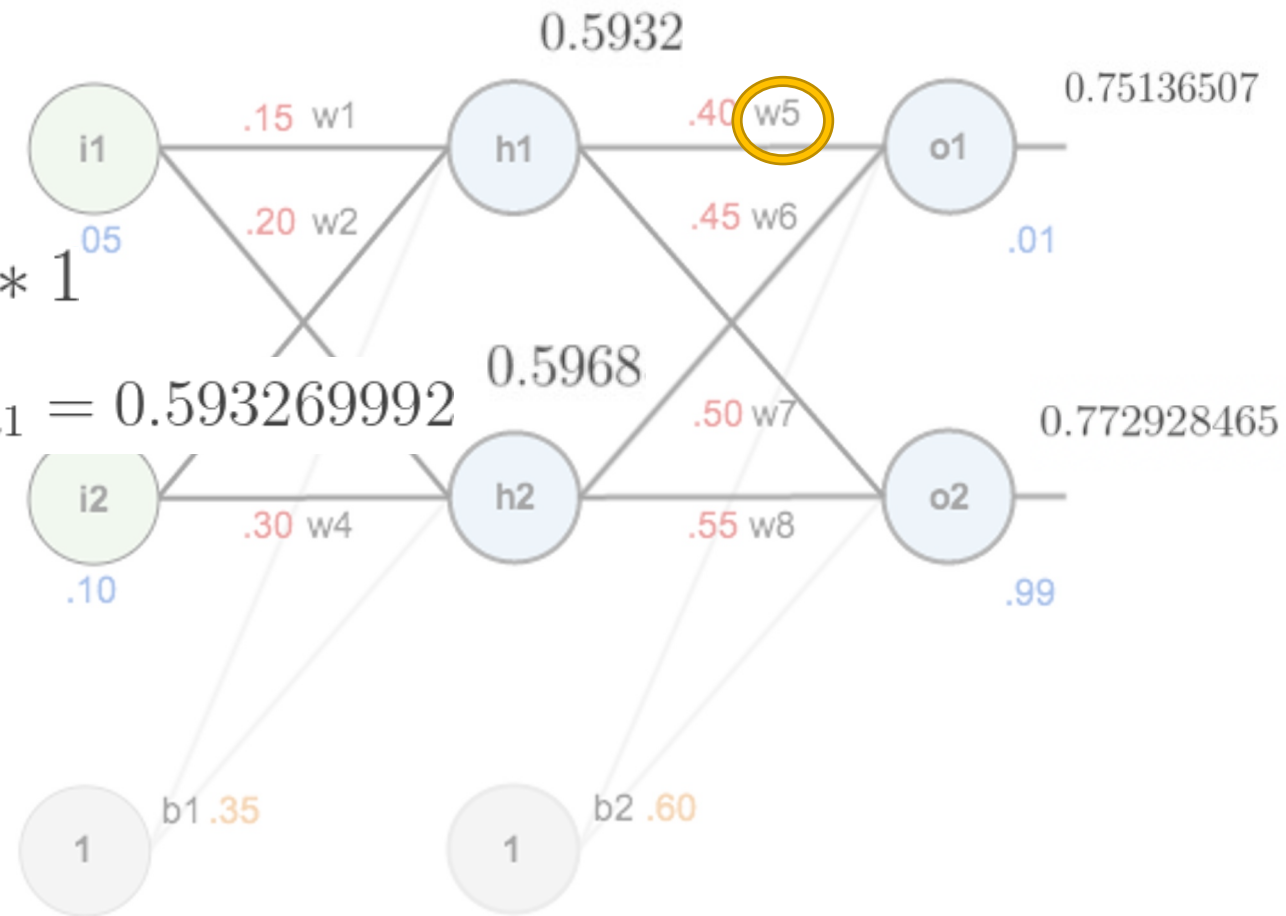

how much does the total net input of o1 change with respect to  $w_5$ ?

# Example - The Backward Pass ←

$$\frac{\partial E_{total}}{\partial w_5} = \frac{\partial E_{total}}{\partial out_{o1}} * \frac{\partial out_{o1}}{\partial net_{o1}} * \frac{\partial net_{o1}}{\partial w_5}$$

$$\frac{\partial E_{total}}{\partial w_5} = 0.74136507 * 0.186815602 * 0.593269992 = 0.082167041$$

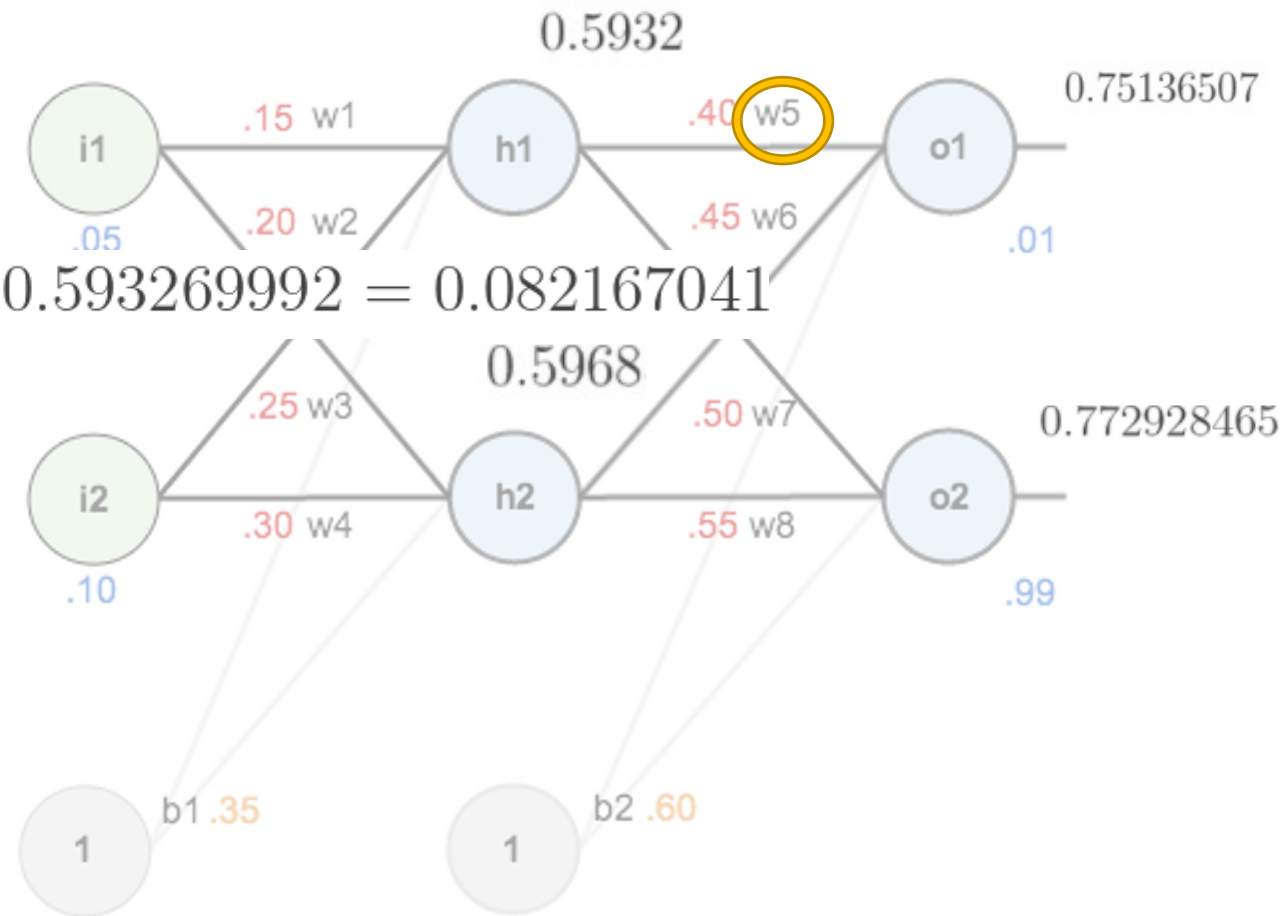

Put everything together



# Example - The Backward Pass ←

Slope of the Activation Function obtained as partial derivative by the Gradient Descent

$$\frac{\partial E_{total}}{\partial w_5} = \frac{\partial E_{total}}{\partial out_{o1}} * \frac{\partial out_{o1}}{\partial net_{o1}} * \frac{\partial net_{o1}}{\partial w_5}$$

$$\frac{\partial E_{total}}{\partial w_5} = -(target_{o1} - out_{o1}) * out_{o1}(1 - out_{o1}) * out_{h1}$$

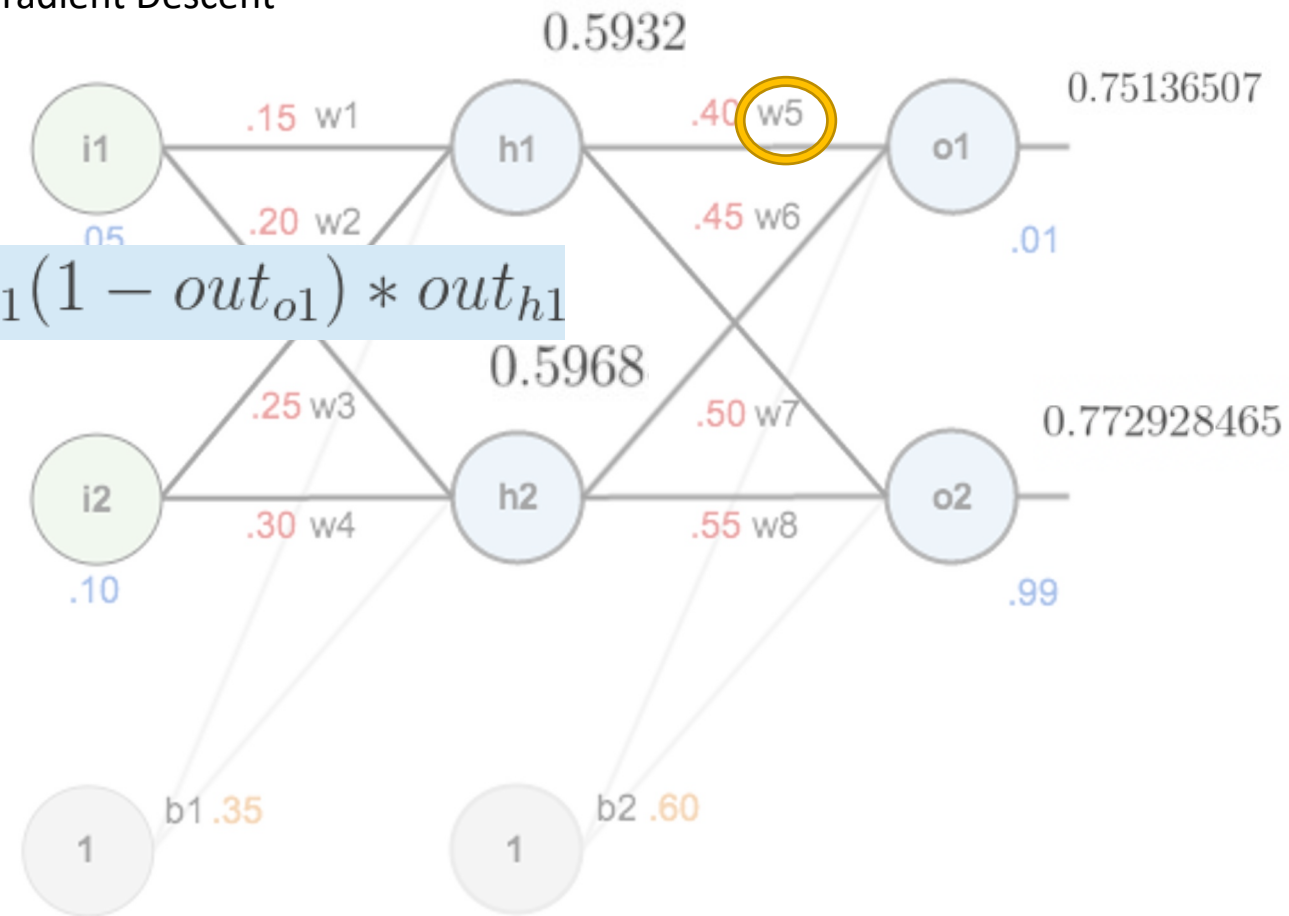

Rewriting as delta rule

# Example - The Backward Pass ←

$$\frac{\partial E_{total}}{\partial w_5} = \frac{\partial E_{total}}{\partial out_{o1}} * \frac{\partial out_{o1}}{\partial net_{o1}} * \frac{\partial net_{o1}}{\partial w_5}$$

$$\frac{\partial E_{total}}{\partial w_5} = -(target_{o1} - out_{o1}) * out_{o1} (1 - out_{o1}) * out_{h1}$$

$$\delta_{o1} = \frac{\partial E_{total}}{\partial out_{o1}} * \frac{\partial out_{o1}}{\partial net_{o1}} = \frac{\partial E_{total}}{\partial net_{o1}}$$

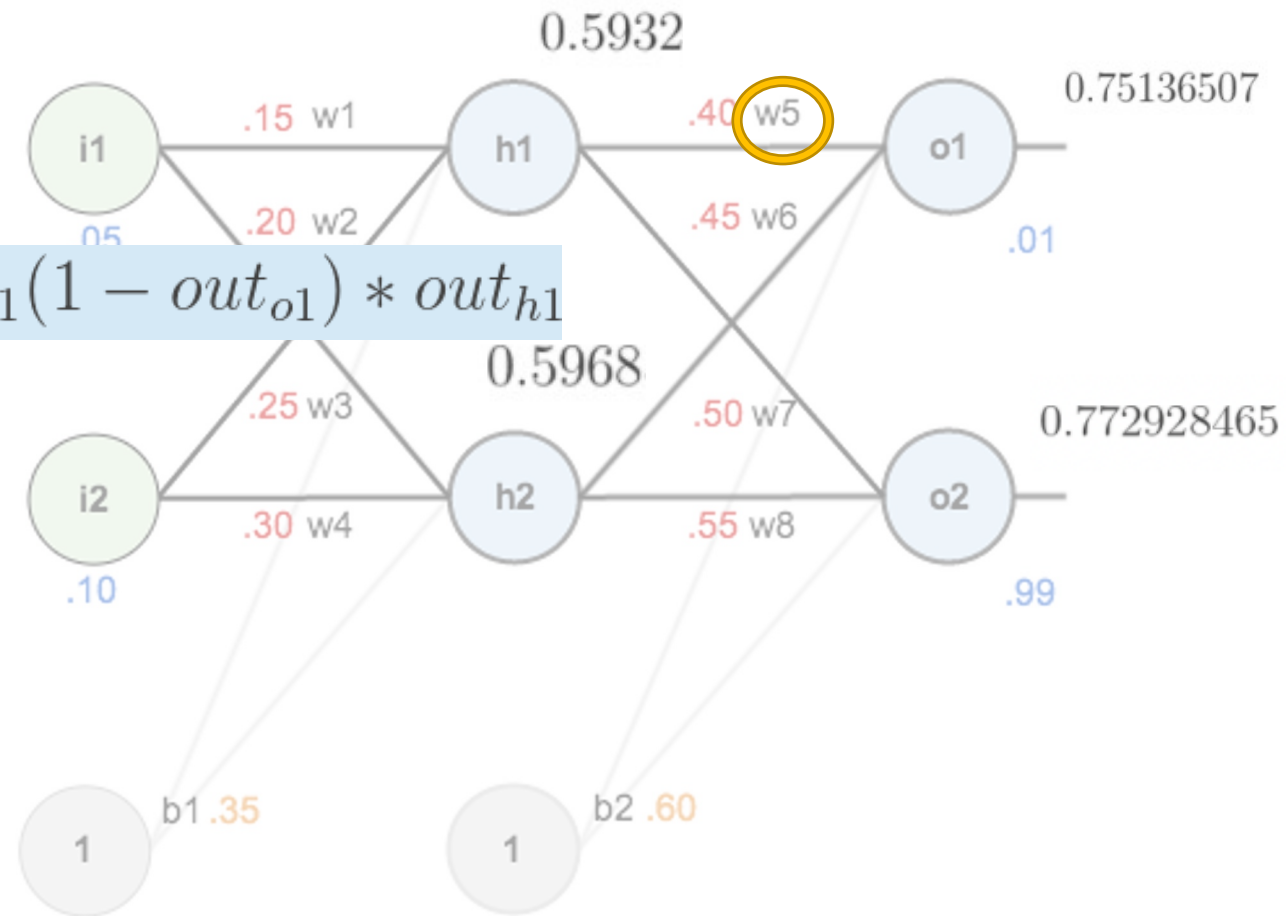

Rewriting as delta rule

# Example - The Backward Pass ←

$$\frac{\partial E_{total}}{\partial w_5} = \frac{\partial E_{total}}{\partial out_{o1}} * \frac{\partial out_{o1}}{\partial net_{o1}} * \frac{\partial net_{o1}}{\partial w_5}$$

$$\frac{\partial E_{total}}{\partial w_5} = -(target_{o1} - out_{o1}) * out_{o1}(1 - out_{o1}) * out_{h1}$$

$$\delta_{o1} = \frac{\partial E_{total}}{\partial out_{o1}} * \frac{\partial out_{o1}}{\partial net_{o1}} = \frac{\partial E_{total}}{\partial net_{o1}}$$

$$\delta_{o1} = -(target_{o1} - out_{o1}) * out_{o1}(1 - out_{o1})$$

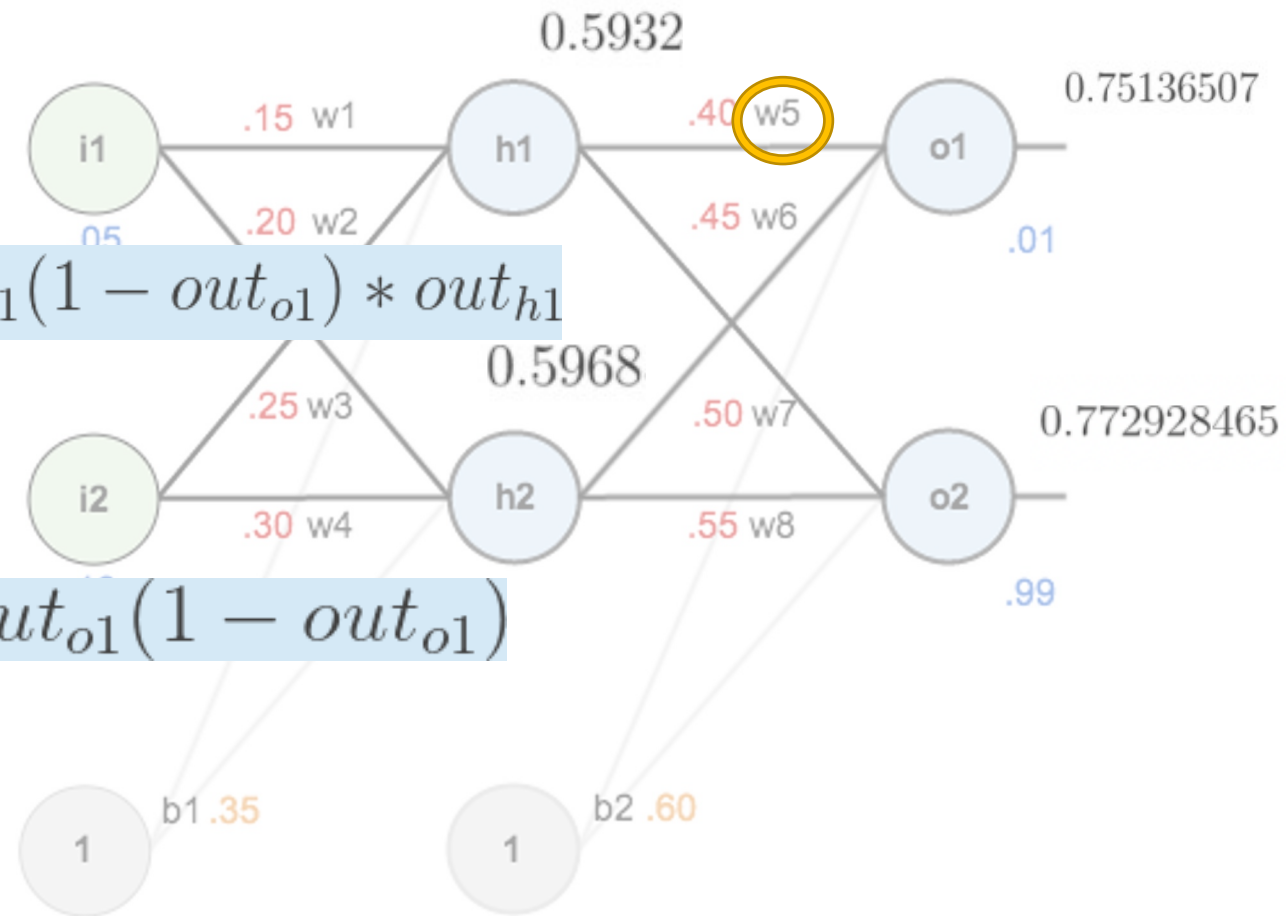

Rewriting as delta rule

# Example - The Backward Pass ←

$$\frac{\partial E_{total}}{\partial w_5} = \frac{\partial E_{total}}{\partial out_{o1}} * \frac{\partial out_{o1}}{\partial net_{o1}} * \frac{\partial net_{o1}}{\partial w_5}$$

$$\frac{\partial E_{total}}{\partial w_5} = -(target_{o1} - out_{o1}) * out_{o1}(1 - out_{o1}) * out_{h1}$$

$$\delta_{o1} = \frac{\partial E_{total}}{\partial out_{o1}} * \frac{\partial out_{o1}}{\partial net_{o1}} = \frac{\partial E_{total}}{\partial net_{o1}}$$

$$\delta_{o1} = -(target_{o1} - out_{o1}) * out_{o1}(1 - out_{o1})$$

$$\frac{\partial E_{total}}{\partial w_5} = \delta_{o1} out_{h1}$$

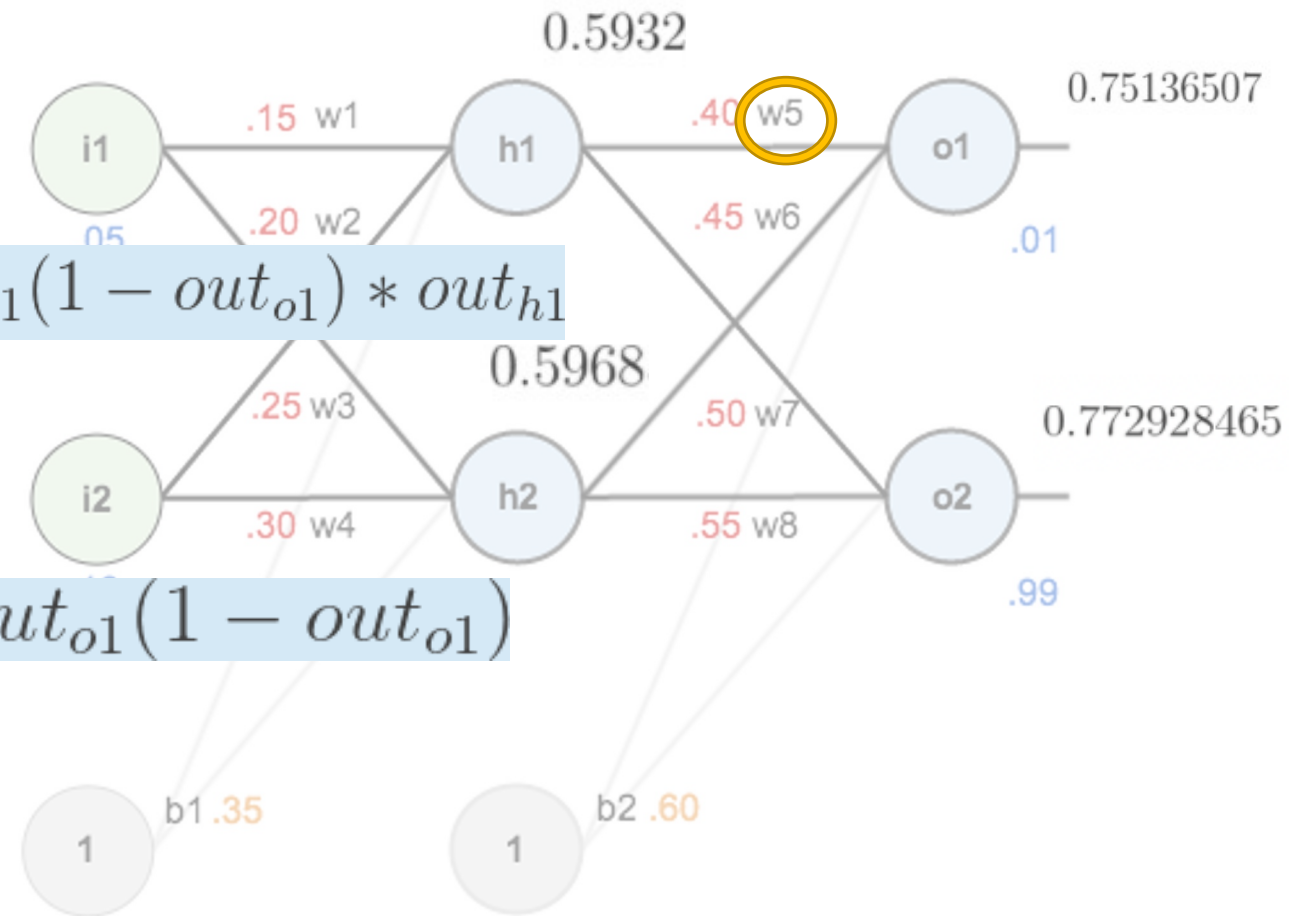

Rewriting as delta rule

# Example - The Backward Pass ←

$$\frac{\partial E_{total}}{\partial w_5} = \frac{\partial E_{total}}{\partial out_{o1}} * \frac{\partial out_{o1}}{\partial net_{o1}} * \frac{\partial net_{o1}}{\partial w_5}$$

$$\frac{\partial E_{total}}{\partial w_5} = 0.74136507 * 0.186815602 * 0.593269992 = 0.082167041$$

$$w_5^+ = w_5 - \eta * \frac{\partial E_{total}}{\partial w_5} = 0.4 - 0.5 * 0.082167041 = 0.35891648$$

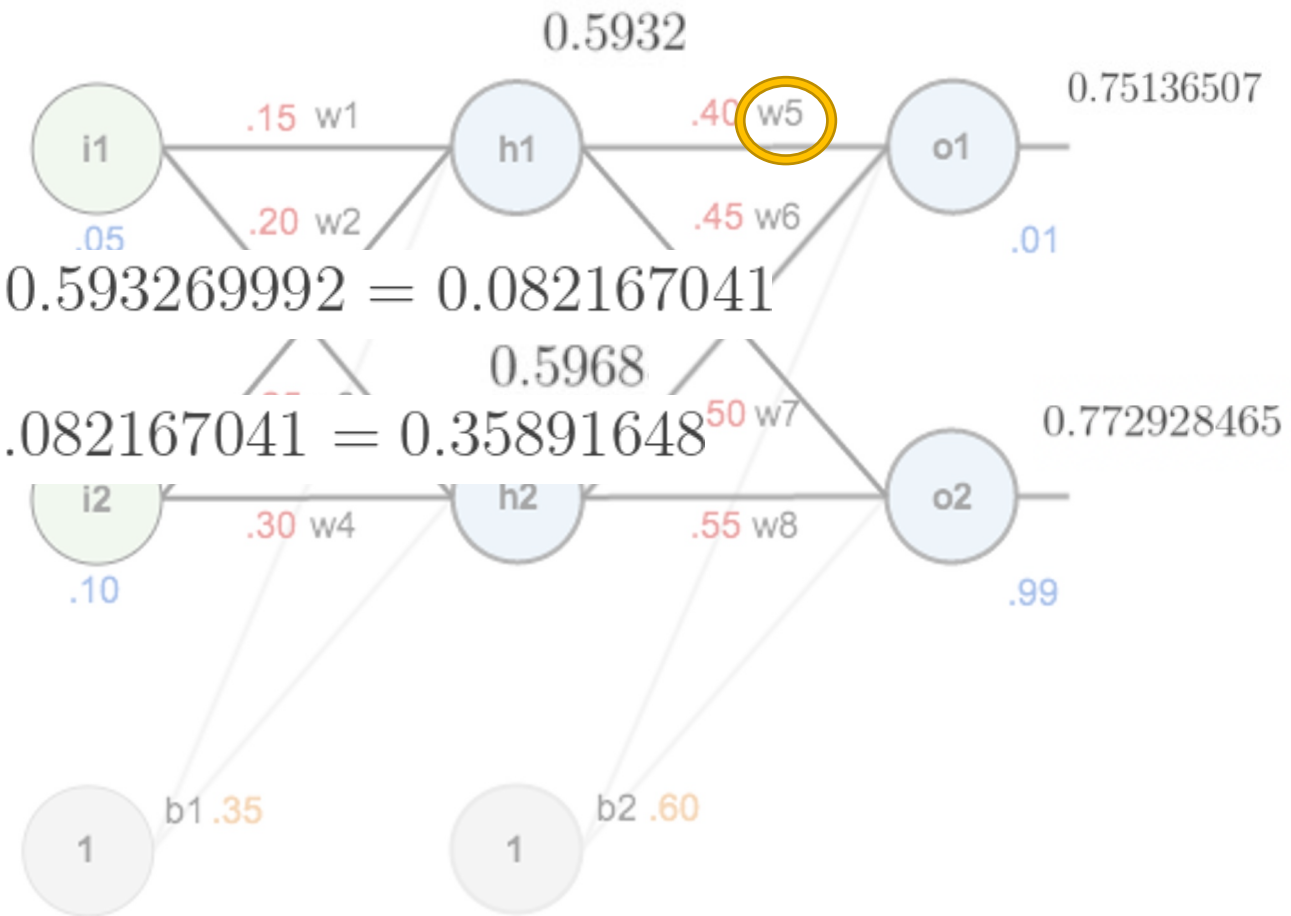

Apply the step size to update w5.

# Example - The Backward Pass ←

$$\frac{\partial E_{total}}{\partial w_5} = \frac{\partial E_{total}}{\partial out_{o1}} * \frac{\partial out_{o1}}{\partial net_{o1}} * \frac{\partial net_{o1}}{\partial w_5}$$

$$\frac{\partial E_{total}}{\partial w_5} = 0.74136507 * 0.186815602 * 0.593269992 = 0.082167041$$

$$w_5^+ = w_5 - \eta * \frac{\partial E_{total}}{\partial w_5} = 0.4 - 0.5 * 0.082167041 = 0.35891648$$

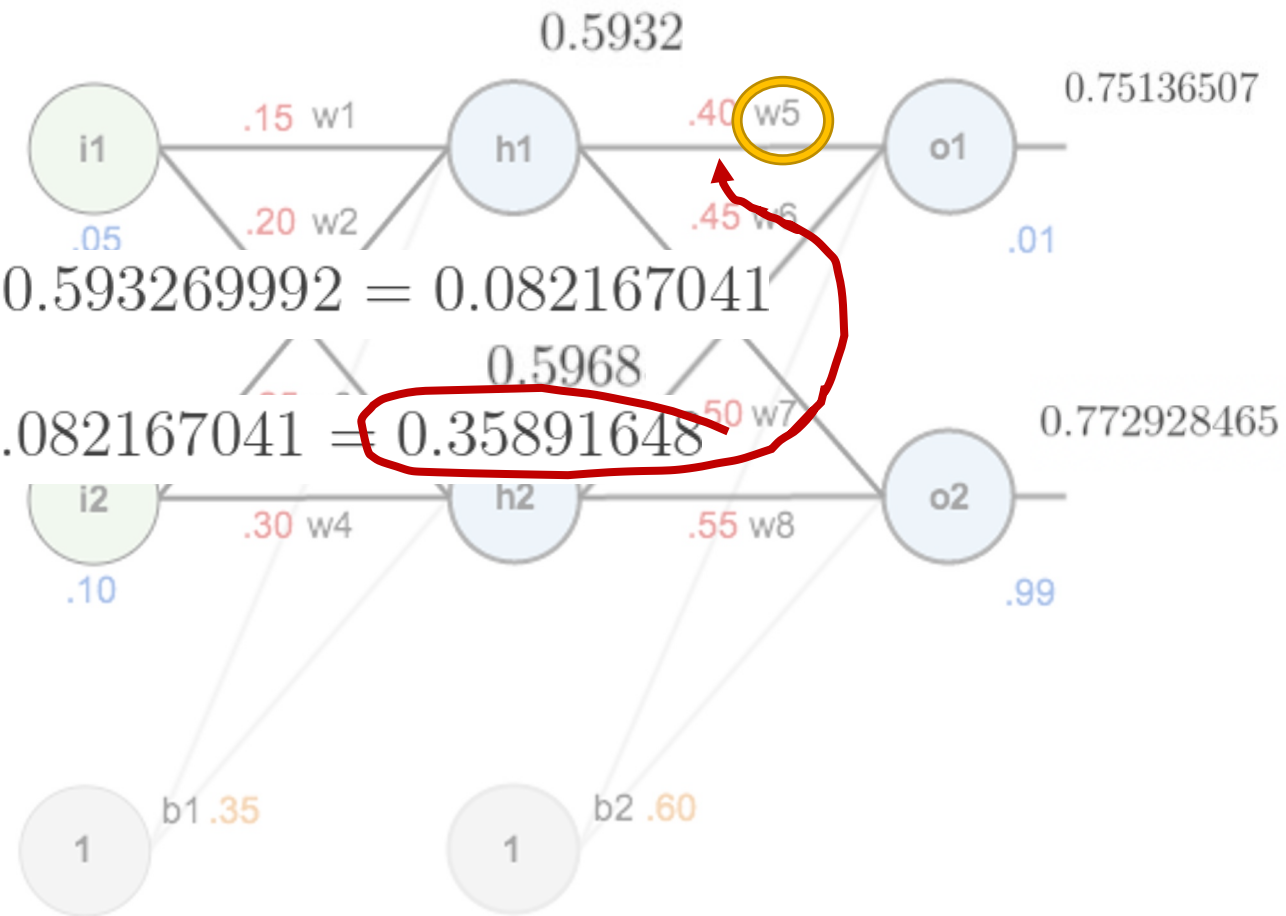

Apply the step size to update w5.

# Example - The Backward Pass ←

$$\frac{\partial E_{total}}{\partial w_5} = \frac{\partial E_{total}}{\partial out_{o1}} * \frac{\partial out_{o1}}{\partial net_{o1}} * \frac{\partial net_{o1}}{\partial w_5}$$

$$\frac{\partial E_{total}}{\partial w_5} = 0.74136507 * 0.186815602 * 0.593269992 = 0.082167041$$

$$w_5^+ = w_5 - \eta * \frac{\partial E_{total}}{\partial w_5} = 0.4 - 0.5 * 0.082167041 = 0.35891648$$

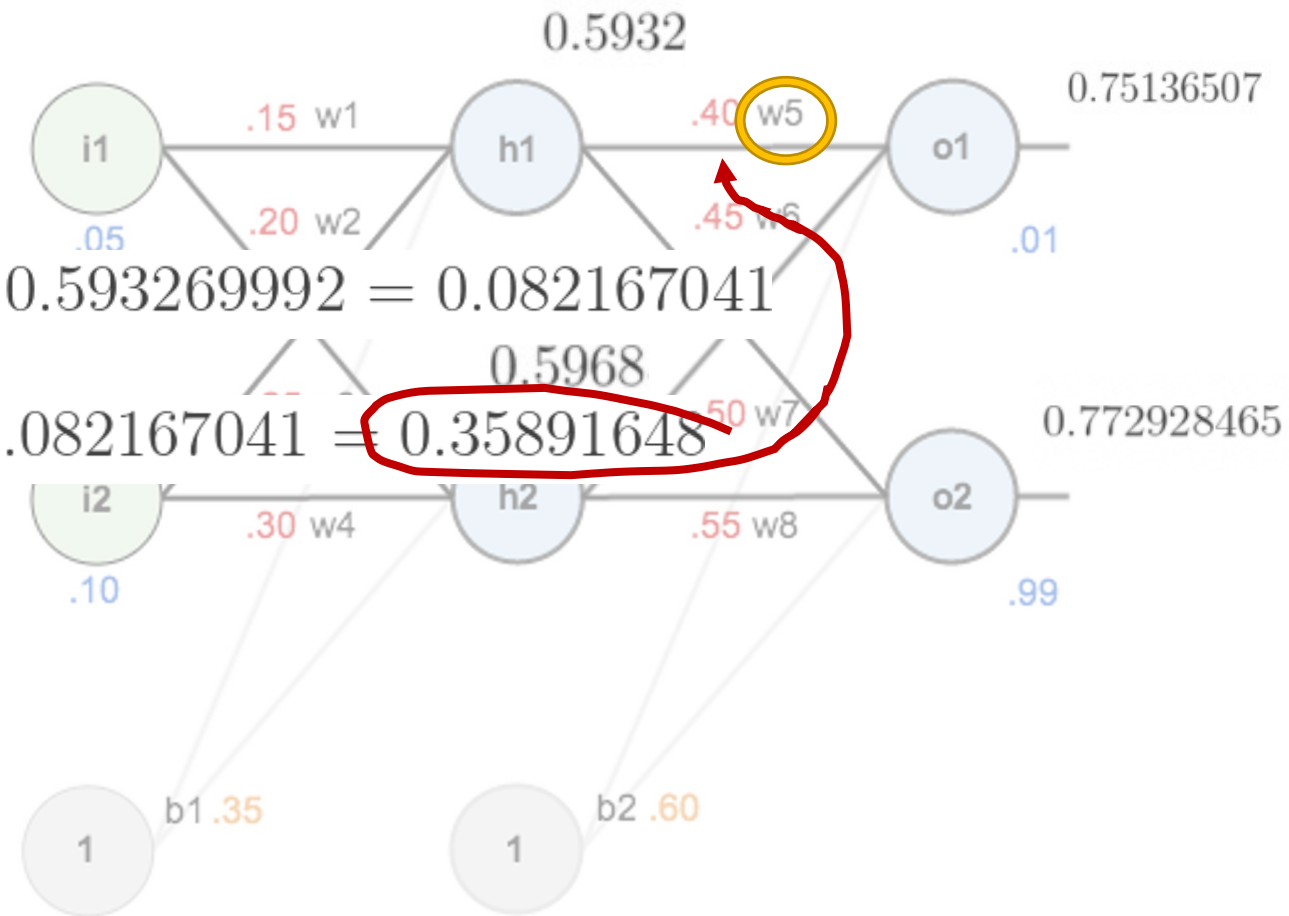

The same calculus is applied to update w6, w7 and w8

# Example - The Backward Pass ←

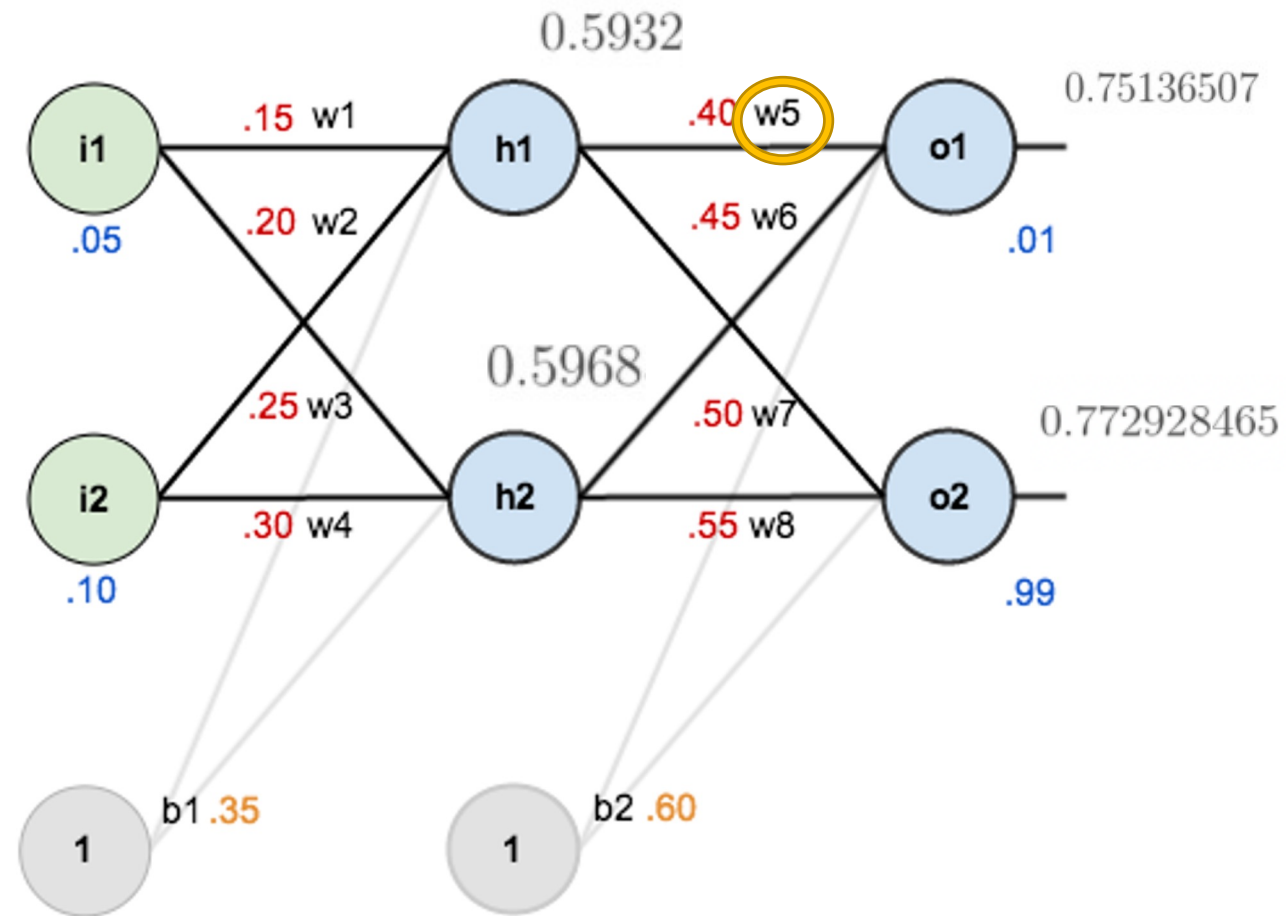

After that w5, w6, w7 and w8 have been updated we continue backwards to update w1, w2, w3 and w4



# Example - The Backward Pass ←

$$\frac{\partial E_{total}}{\partial w_1} = \frac{\partial E_{total}}{\partial out_{h1}} * \frac{\partial out_{h1}}{\partial net_{h1}} * \frac{\partial net_{h1}}{\partial w_1}$$

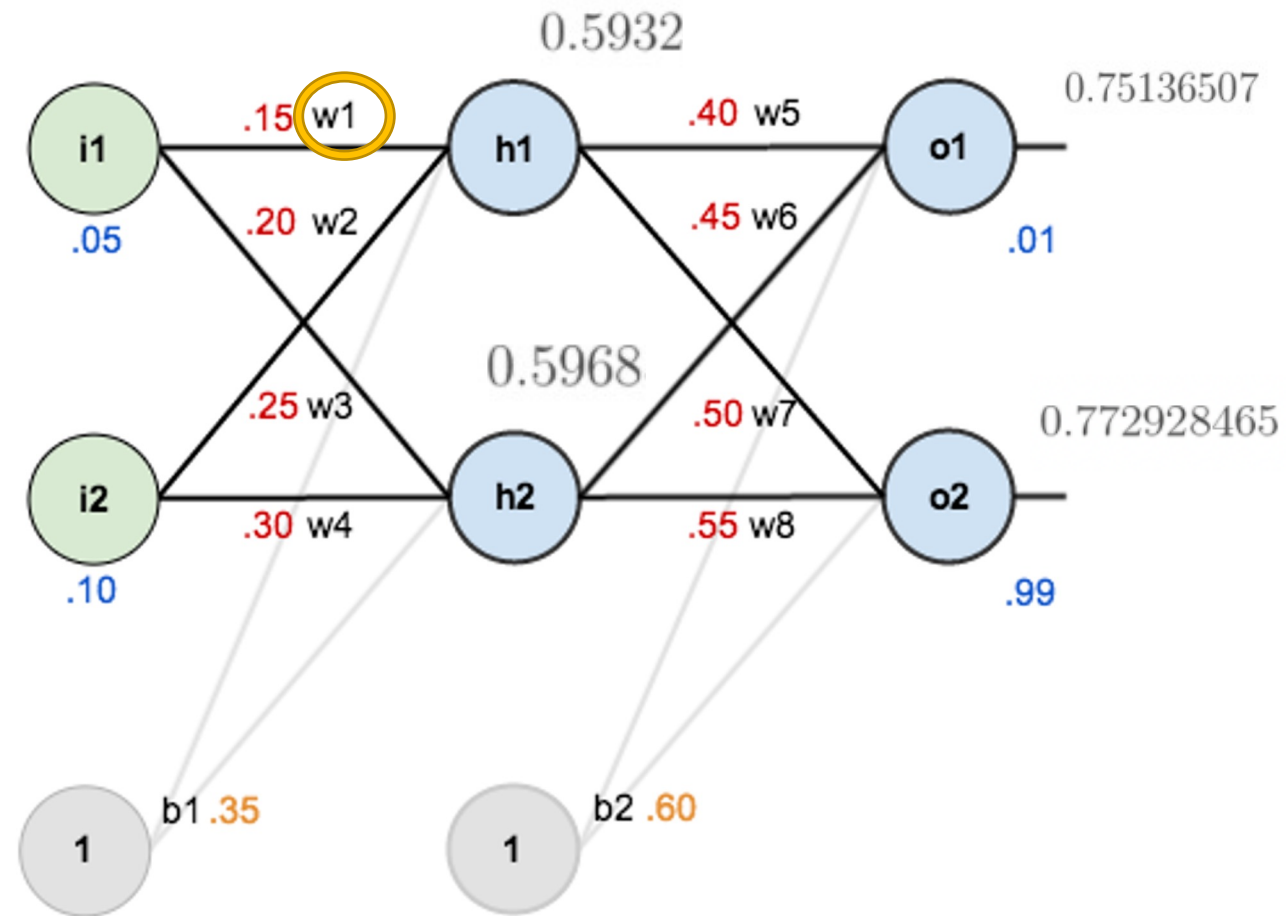

After that w5, w6, w7 and w8 have been updated we continue backwards to update w1, w2, w3 and w4

# Example - The Backward Pass ←

$$\frac{\partial E_{total}}{\partial w_1} = \frac{\partial E_{total}}{\partial out_{h1}} * \frac{\partial out_{h1}}{\partial net_{h1}} * \frac{\partial net_{h1}}{\partial w_1}$$

$$\frac{\partial E_{total}}{\partial w_1} = \frac{\partial E_{total}}{\partial out_{h1}} * \frac{\partial out_{h1}}{\partial net_{h1}} * \frac{\partial net_{h1}}{\partial w_1}$$

$$\downarrow$$

$$\frac{\partial E_{total}}{\partial out_{h1}} = \frac{\partial E_{o1}}{\partial out_{h1}} + \frac{\partial E_{o2}}{\partial out_{h1}}$$

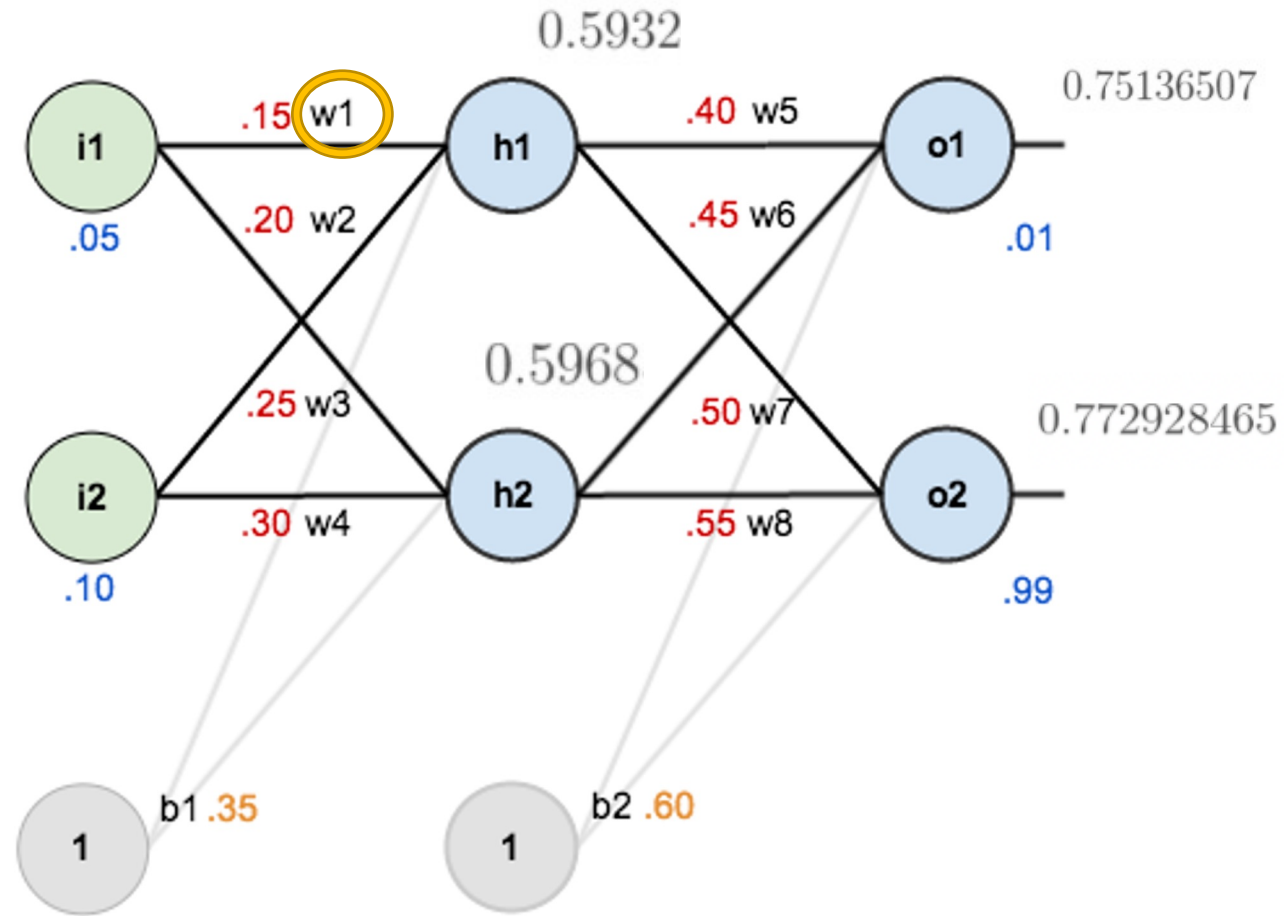
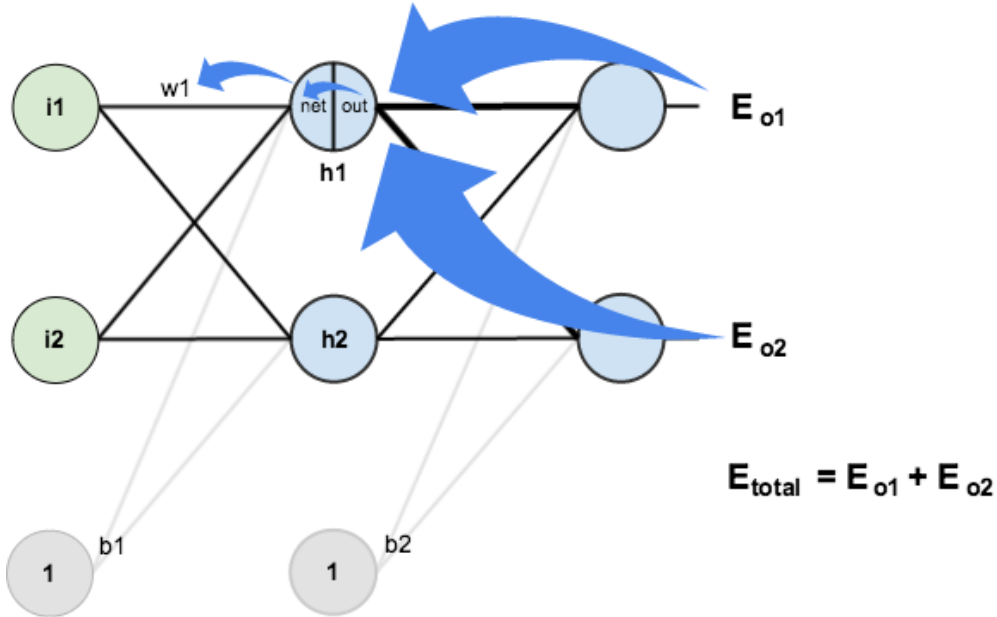

# Example - The Backward Pass ←

$$\frac{\partial E_{total}}{\partial w_1} = \frac{\partial E_{total}}{\partial out_{h1}} * \frac{\partial out_{h1}}{\partial net_{h1}} * \frac{\partial net_{h1}}{\partial w_1}$$

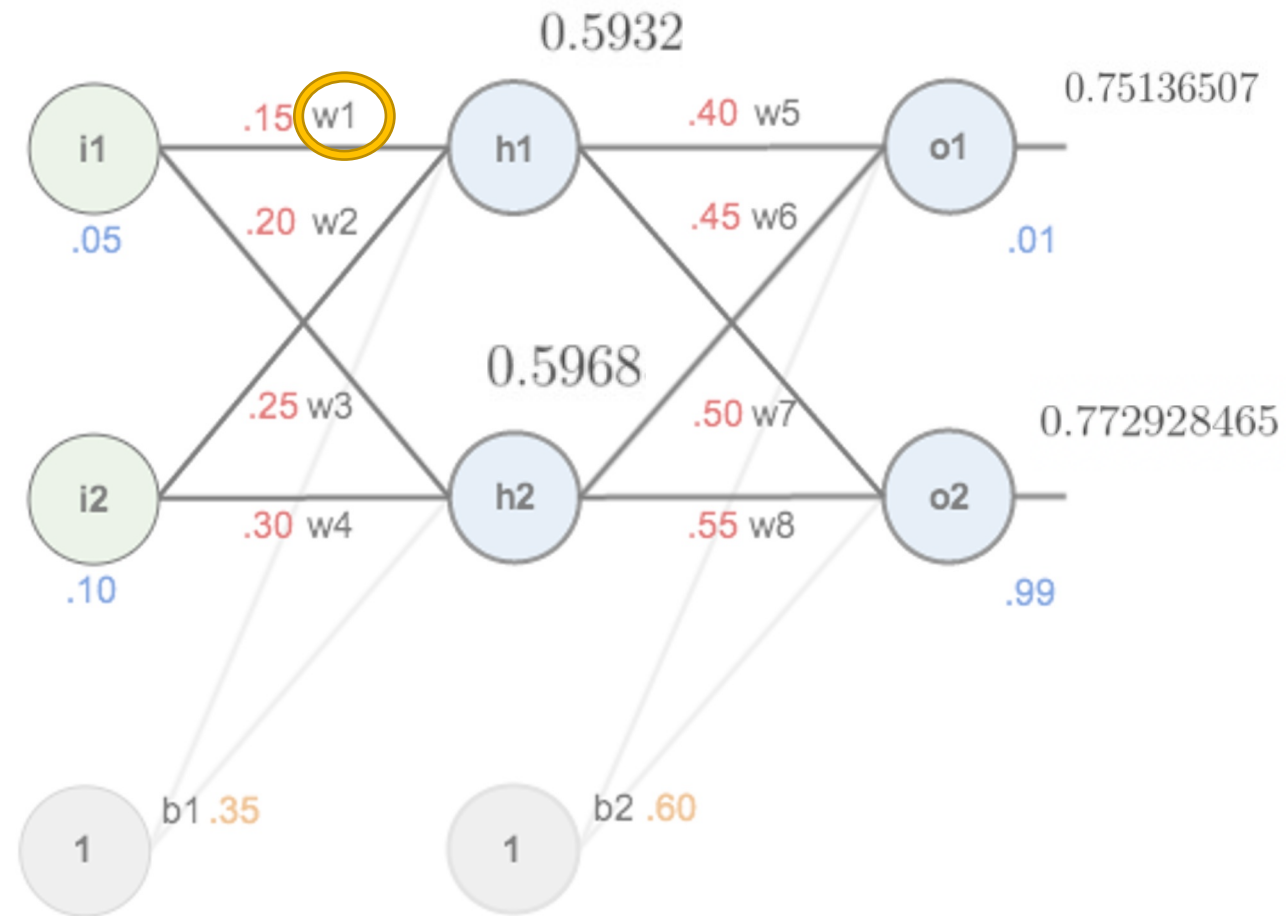

# Example - The Backward Pass ←

$$\frac{\partial E_{total}}{\partial w_1} = \frac{\partial E_{total}}{\partial out_{h1}} * \frac{\partial out_{h1}}{\partial net_{h1}} * \frac{\partial net_{h1}}{\partial w_1}$$

$$\frac{\partial E_{total}}{\partial out_{h1}} = \frac{\partial E_{o1}}{\partial out_{h1}} + \frac{\partial E_{o2}}{\partial out_{h1}}$$

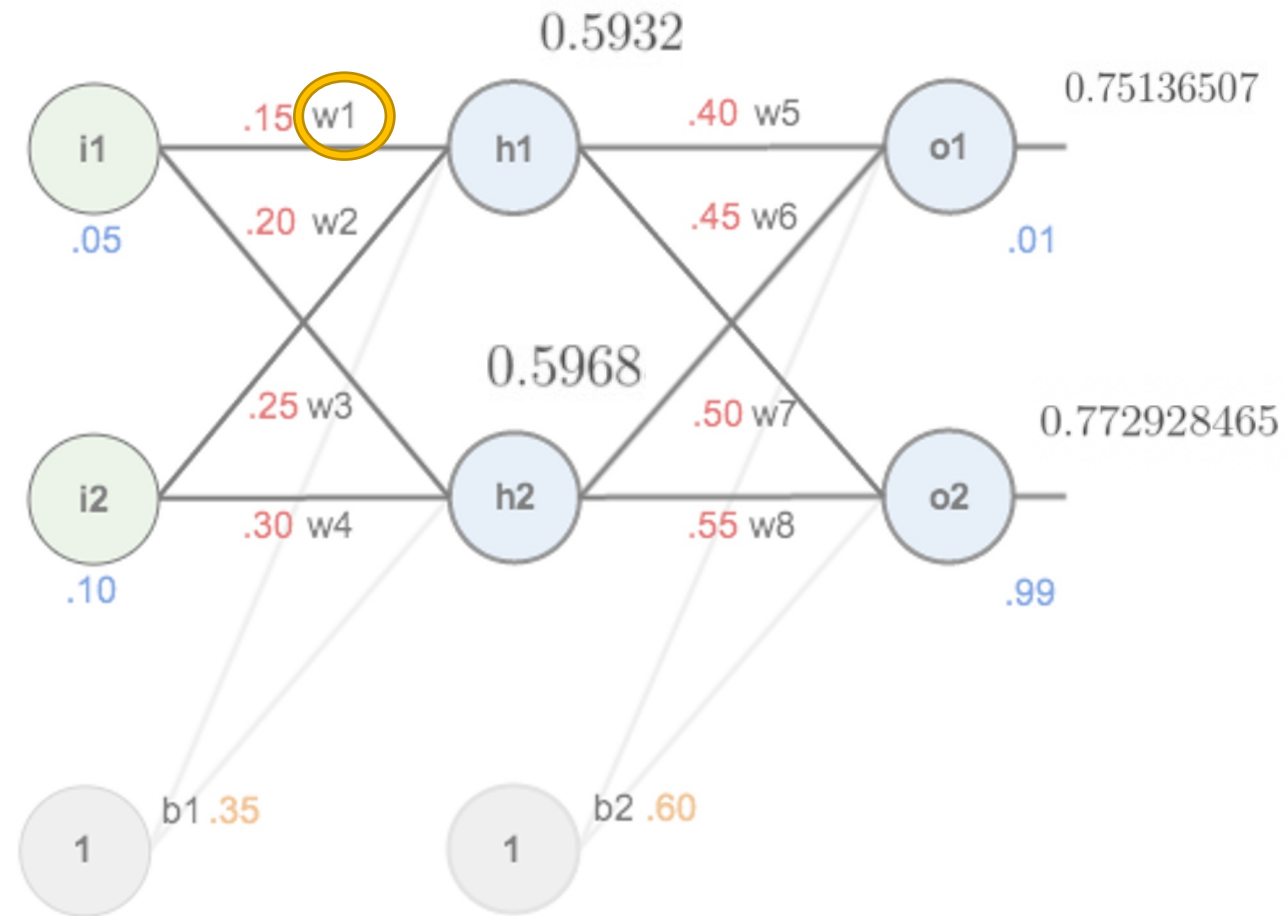

# Example - The Backward Pass ←

$$\frac{\partial E_{total}}{\partial w_1} = \frac{\partial E_{total}}{\partial out_{h1}} * \frac{\partial out_{h1}}{\partial net_{h1}} * \frac{\partial net_{h1}}{\partial w_1}$$

$$\frac{\partial E_{total}}{\partial out_{h1}} = \frac{\partial E_{o1}}{\partial out_{h1}} + \frac{\partial E_{o2}}{\partial out_{h1}}$$

$$\frac{\partial E_{o1}}{\partial out_{h1}} = \frac{\partial E_{o1}}{\partial net_{o1}} * \frac{\partial net_{o1}}{\partial out_{h1}}$$

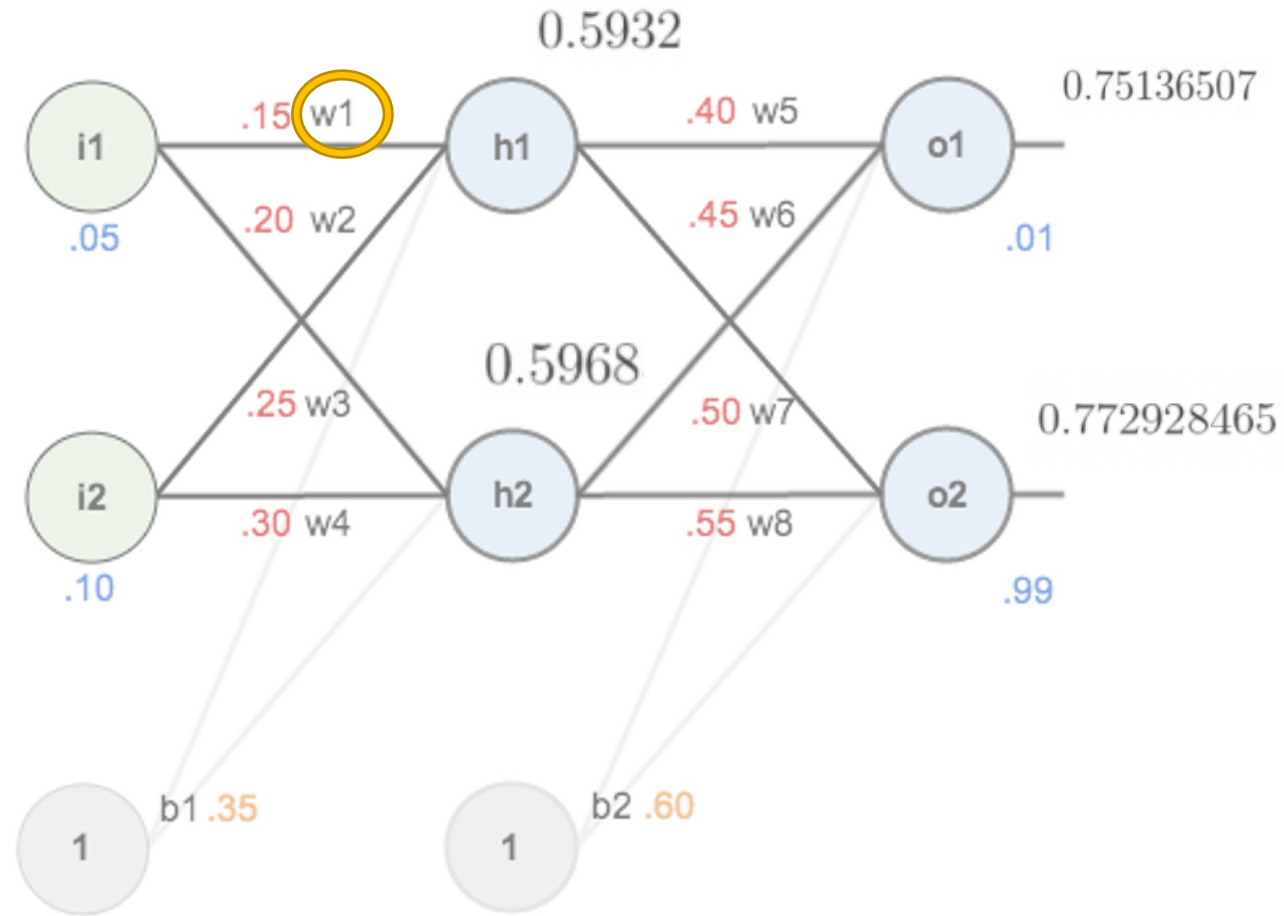

# Example - The Backward Pass ←

$$\frac{\partial E_{total}}{\partial w_1} = \frac{\partial E_{total}}{\partial out_{h1}} * \frac{\partial out_{h1}}{\partial net_{h1}} * \frac{\partial net_{h1}}{\partial w_1}$$

$$\frac{\partial E_{total}}{\partial out_{h1}} = \frac{\partial E_{o1}}{\partial out_{h1}} + \frac{\partial E_{o2}}{\partial out_{h1}}$$

$$\frac{\partial E_{o1}}{\partial out_{h1}} = \frac{\partial E_{o1}}{\partial net_{o1}} * \frac{\partial net_{o1}}{\partial out_{h1}}$$

$$\frac{\partial E_{o1}}{\partial net_{o1}} = \frac{\partial E_{o1}}{\partial out_{o1}} * \frac{\partial out_{o1}}{\partial net_{o1}} = 0.74136507 * 0.186815602 = 0.138498562$$

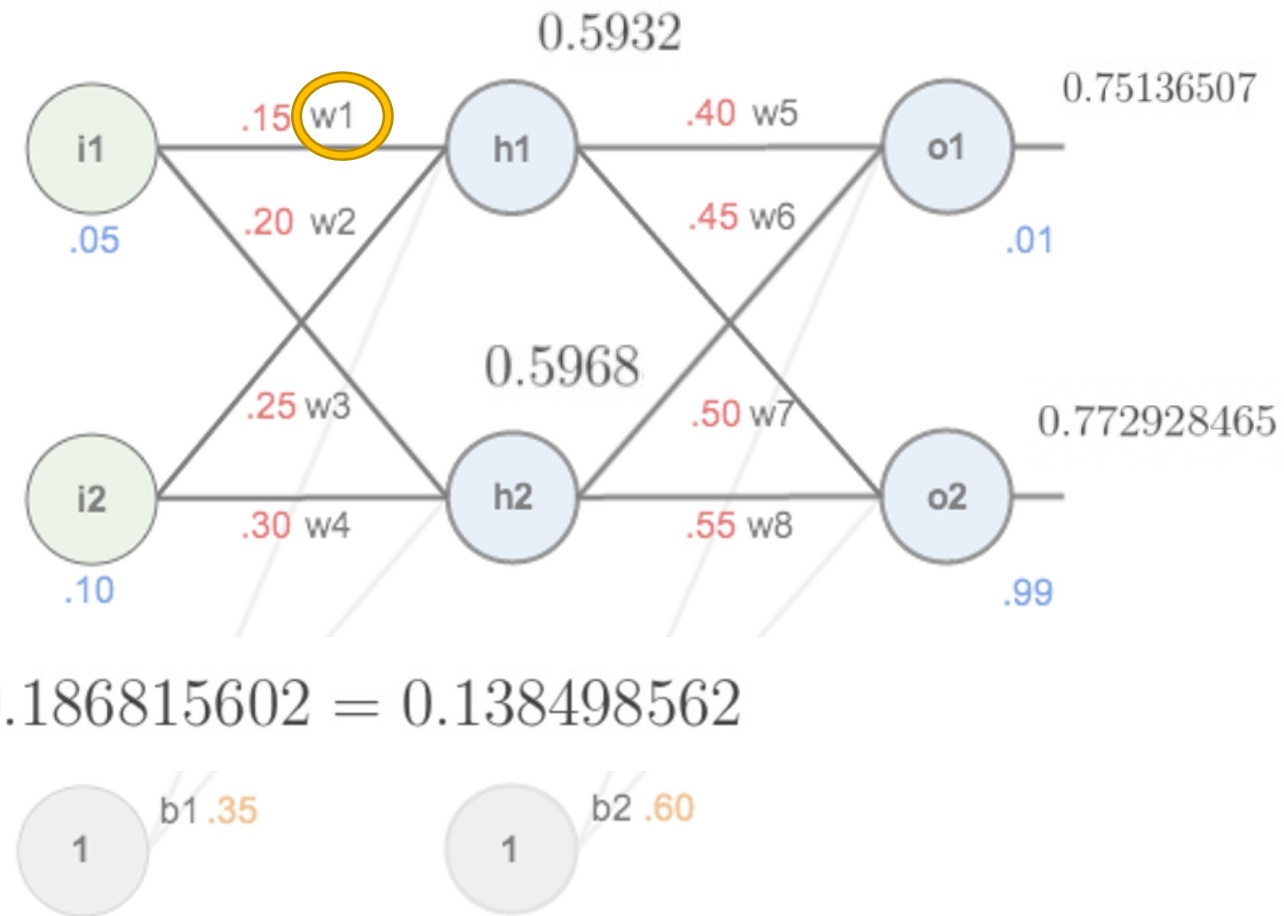

# Example - The Backward Pass ←

$$\frac{\partial E_{total}}{\partial w_1} = \frac{\partial E_{total}}{\partial out_{h1}} * \frac{\partial out_{h1}}{\partial net_{h1}} * \frac{\partial net_{h1}}{\partial w_1}$$

$$\frac{\partial E_{total}}{\partial out_{h1}} = \frac{\partial E_{o1}}{\partial out_{h1}} + \frac{\partial E_{o2}}{\partial out_{h1}}$$

$$\frac{\partial E_{o1}}{\partial out_{h1}} = \frac{\partial E_{o1}}{\partial net_{o1}} * \frac{\partial net_{o1}}{\partial out_{h1}}$$

$$\frac{\partial E_{o1}}{\partial net_{o1}} = \frac{\partial E_{o1}}{\partial out_{o1}} * \frac{\partial out_{o1}}{\partial net_{o1}} = 0.74136507 * 0.186815602 = 0.138498562$$

$$net_{o1} = w_5 * out_{h1} + w_6 * out_{h2} + b_2 * 1$$

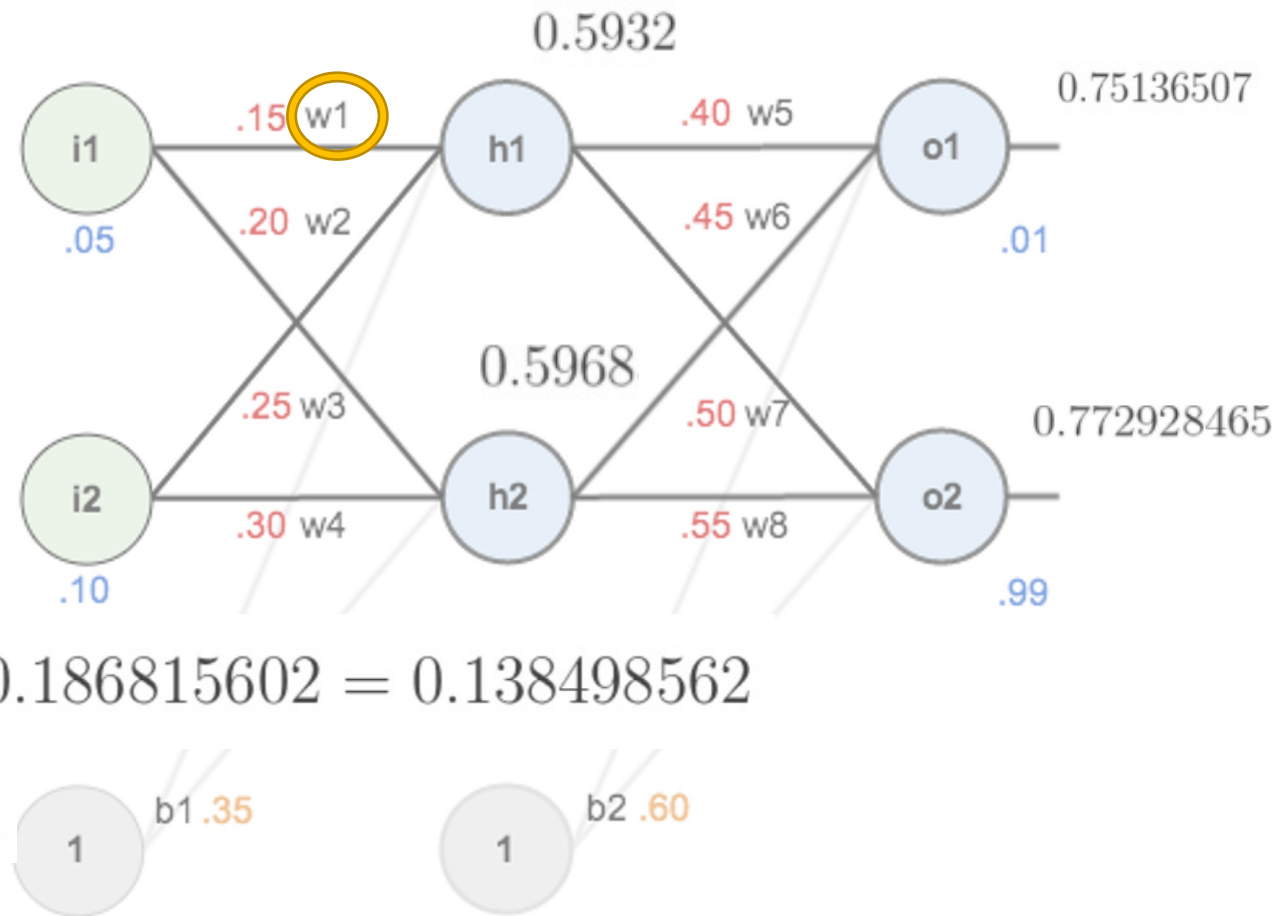

# Example - The Backward Pass ←

$$\frac{\partial E_{total}}{\partial w_1} = \frac{\partial E_{total}}{\partial out_{h1}} * \frac{\partial out_{h1}}{\partial net_{h1}} * \frac{\partial net_{h1}}{\partial w_1}$$

$$\frac{\partial E_{total}}{\partial out_{h1}} = \frac{\partial E_{o1}}{\partial out_{h1}} + \frac{\partial E_{o2}}{\partial out_{h1}}$$

$$\frac{\partial E_{o1}}{\partial out_{h1}} = \frac{\partial E_{o1}}{\partial net_{o1}} * \frac{\partial net_{o1}}{\partial out_{h1}}$$

$$\frac{\partial E_{o1}}{\partial net_{o1}} = \frac{\partial E_{o1}}{\partial out_{o1}} * \frac{\partial out_{o1}}{\partial net_{o1}} = 0.74136507 * 0.186815602 = 0.138498562$$

$$net_{o1} = w_5 * out_{h1} + w_6 * out_{h2} + b_2 * 1$$

$$\frac{\partial net_{o1}}{\partial out_{h1}} = w_5 = 0.40$$

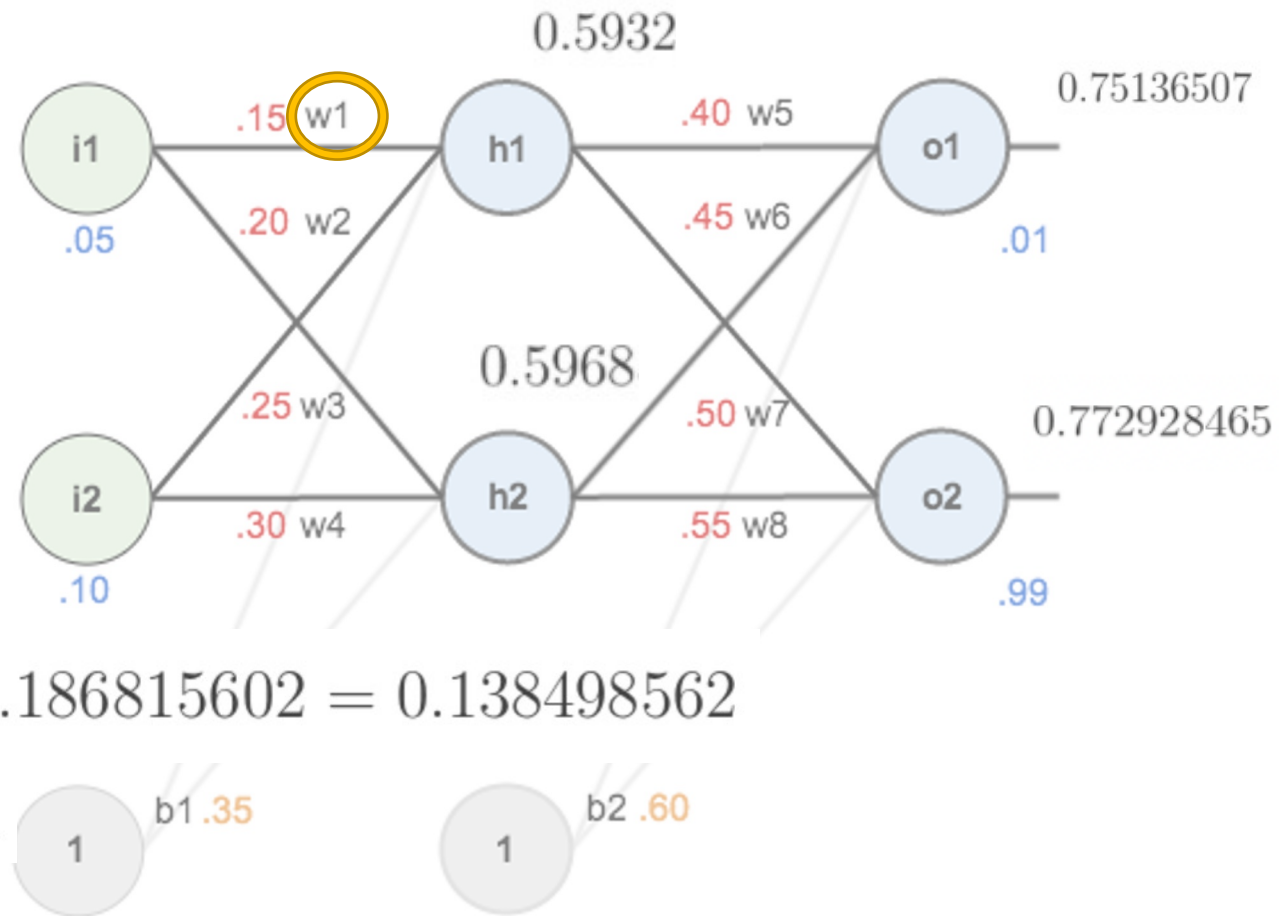



# Example - The Backward Pass ←

$$\frac{\partial E_{total}}{\partial w_1} = \frac{\partial E_{total}}{\partial out_{h1}} * \frac{\partial out_{h1}}{\partial net_{h1}} * \frac{\partial net_{h1}}{\partial w_1}$$

$$\frac{\partial E_{total}}{\partial out_{h1}} = \frac{\partial E_{o1}}{\partial out_{h1}} + \frac{\partial E_{o2}}{\partial out_{h1}}$$

$$\frac{\partial E_{o1}}{\partial out_{h1}} = \frac{\partial E_{o1}}{\partial net_{o1}} * \frac{\partial net_{o1}}{\partial out_{h1}} = 0.138498562 * 0.40 = 0.055399425$$

$$\frac{\partial E_{o1}}{\partial net_{o1}} = \frac{\partial E_{o1}}{\partial out_{o1}} * \frac{\partial out_{o1}}{\partial net_{o1}} = 0.74136507 * 0.186815602 = 0.138498562$$

$$net_{o1} = w_5 * out_{h1} + w_6 * out_{h2} + b_2 * 1$$

$$\frac{\partial net_{o1}}{\partial out_{h1}} = w_5 = 0.40$$

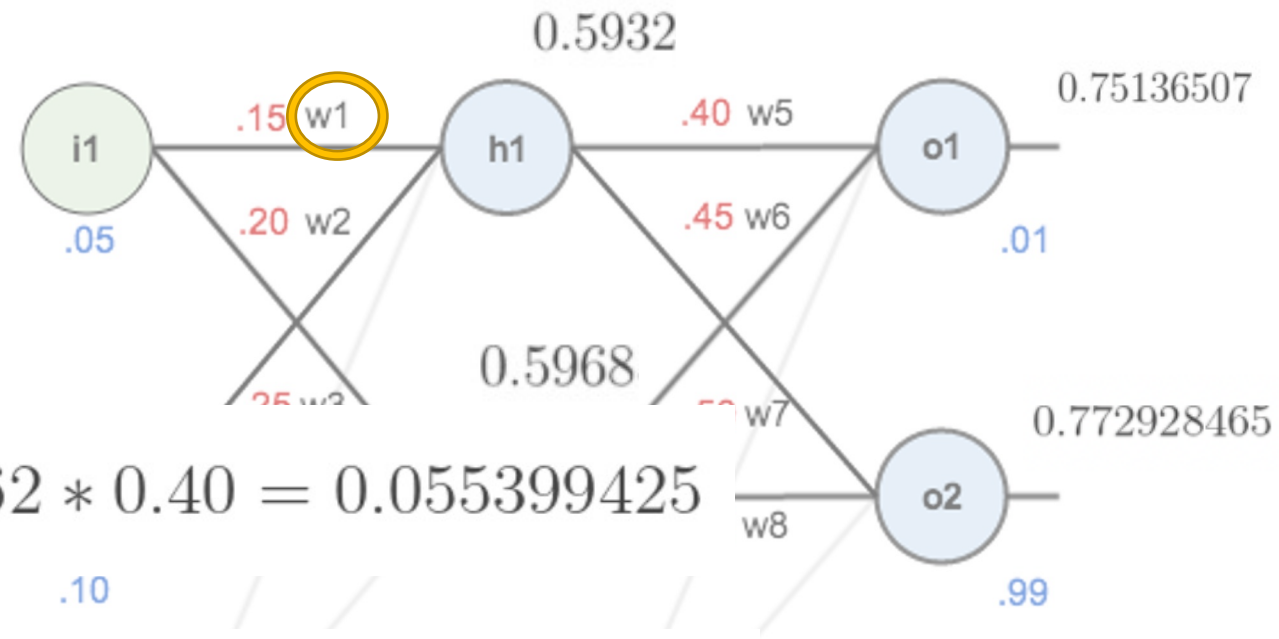

# Example - The Backward Pass ←

$$\frac{\partial E_{total}}{\partial w_1} = \frac{\partial E_{total}}{\partial out_{h1}} * \frac{\partial out_{h1}}{\partial net_{h1}} * \frac{\partial net_{h1}}{\partial w_1}$$

$$\frac{\partial E_{total}}{\partial out_{h1}} = \frac{\partial E_{o1}}{\partial out_{h1}} + \frac{\partial E_{o2}}{\partial out_{h1}}$$

$$\frac{\partial E_{o1}}{\partial out_{h1}} = \frac{\partial E_{o1}}{\partial net_{o1}} * \frac{\partial net_{o1}}{\partial out_{h1}} = 0.138498562 * 0.40 = 0.055399425$$

$$\frac{\partial E_{o1}}{\partial net_{o1}} = \frac{\partial E_{o1}}{\partial out_{o1}} * \frac{\partial out_{o1}}{\partial net_{o1}} = 0.74136507 * 0.186815602 = 0.138498562$$

$$net_{o1} = w_5 * out_{h1} + w_6 * out_{h2} + b_2 * 1$$

$$\frac{\partial net_{o1}}{\partial out_{h1}} = w_5 = 0.40$$

Same process is followed for

$$\frac{\partial E_{o2}}{\partial out_{h1}} = -0.019049119$$

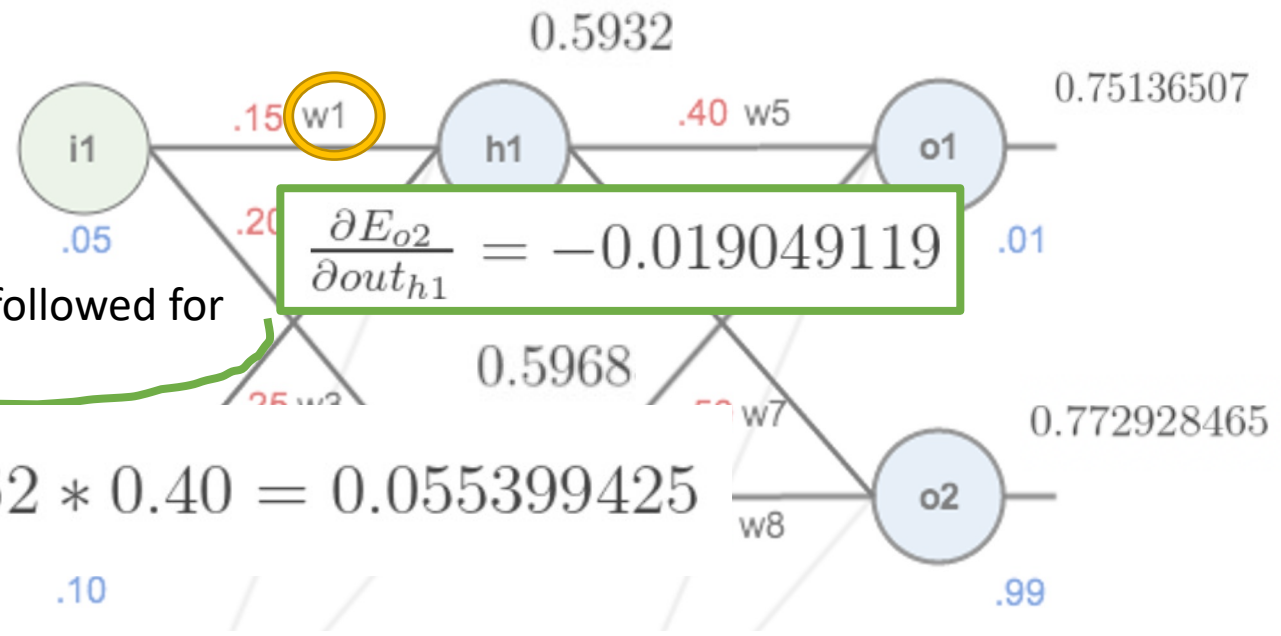

# Example - The Backward Pass ←

$$\frac{\partial E_{total}}{\partial w_1} = \frac{\partial E_{total}}{\partial out_{h1}} * \frac{\partial out_{h1}}{\partial net_{h1}} * \frac{\partial net_{h1}}{\partial w_1}$$

$$\frac{\partial E_{total}}{\partial out_{h1}} = \frac{\partial E_{o1}}{\partial out_{h1}} + \frac{\partial E_{o2}}{\partial out_{h1}} = 0.055399425 + -0.019049119 = 0.036350306$$

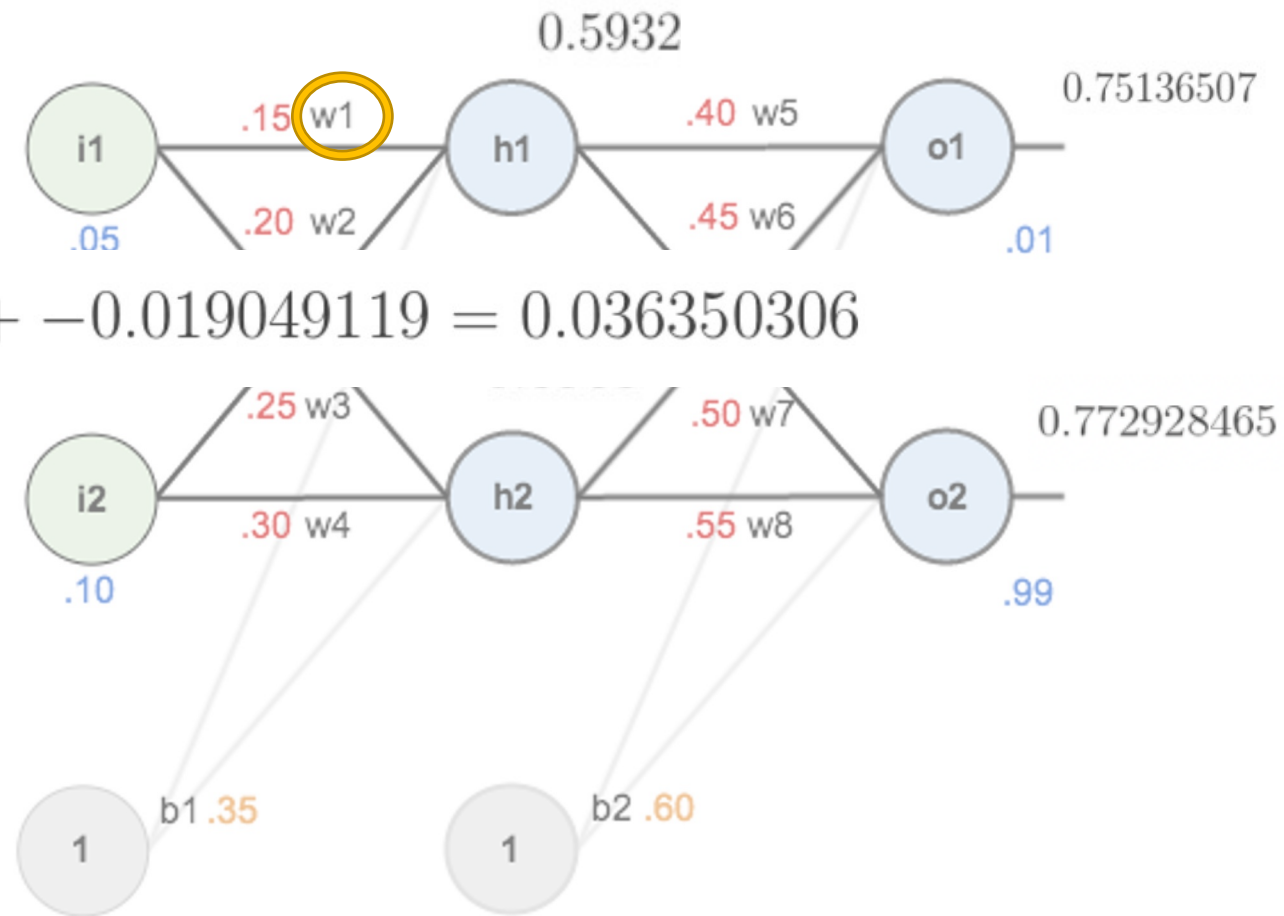

# Example - The Backward Pass ←

$$\frac{\partial E_{total}}{\partial w_1} = \frac{\partial E_{total}}{\partial out_{h1}} * \frac{\partial out_{h1}}{\partial net_{h1}} * \frac{\partial net_{h1}}{\partial w_1}$$

$$out_{h1} = \frac{1}{1+e^{-net_{h1}}}$$

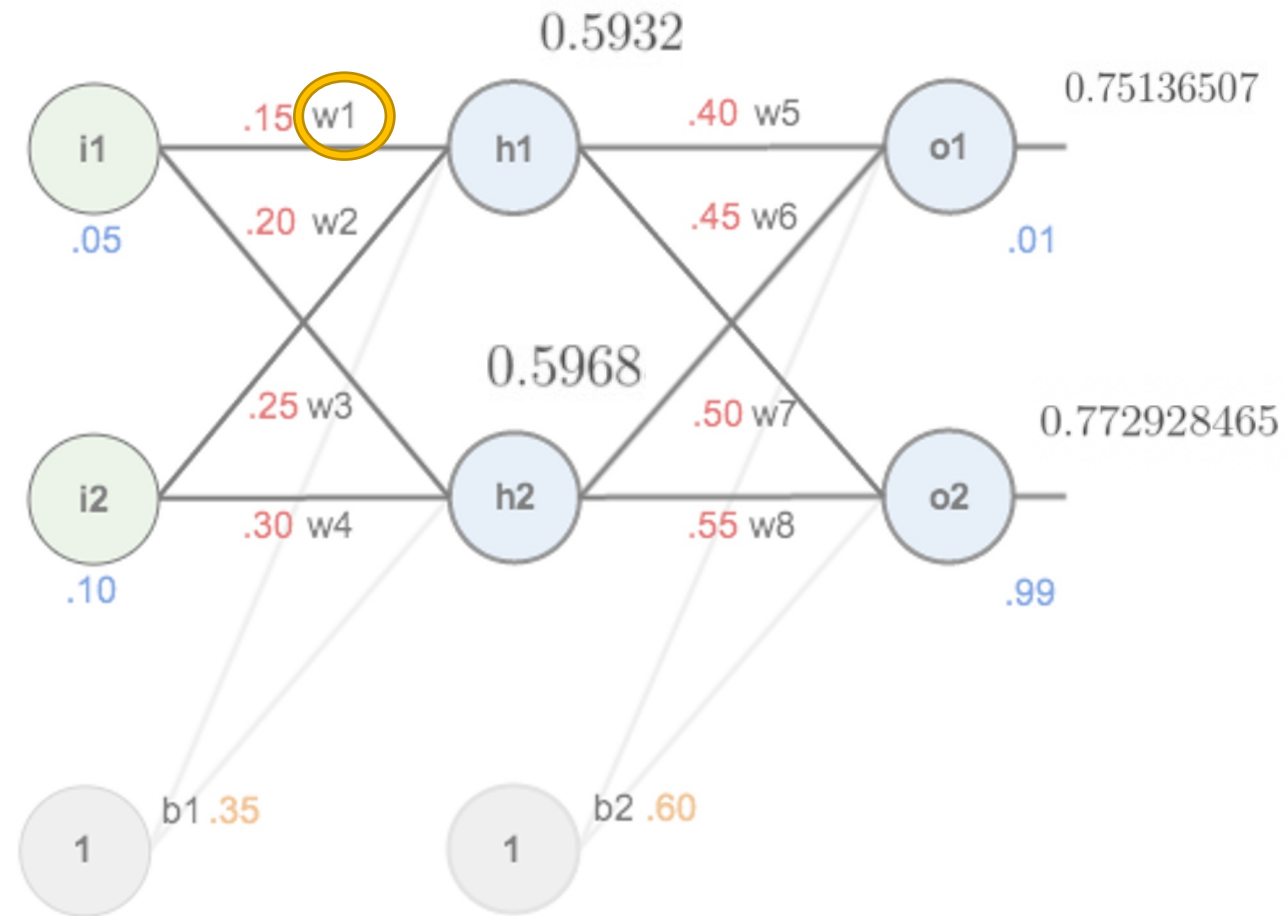

# Example - The Backward Pass ←

$$\frac{\partial E_{total}}{\partial w_1} = \frac{\partial E_{total}}{\partial out_{h1}} * \frac{\partial out_{h1}}{\partial net_{h1}} * \frac{\partial net_{h1}}{\partial w_1}$$

$$out_{h1} = \frac{1}{1 + e^{-net_{h1}}}$$

$$\frac{\partial out_{h1}}{\partial net_{h1}} = out_{h1}(1 - out_{h1}) = 0.59326999(1 - 0.59326999) = 0.241300709$$

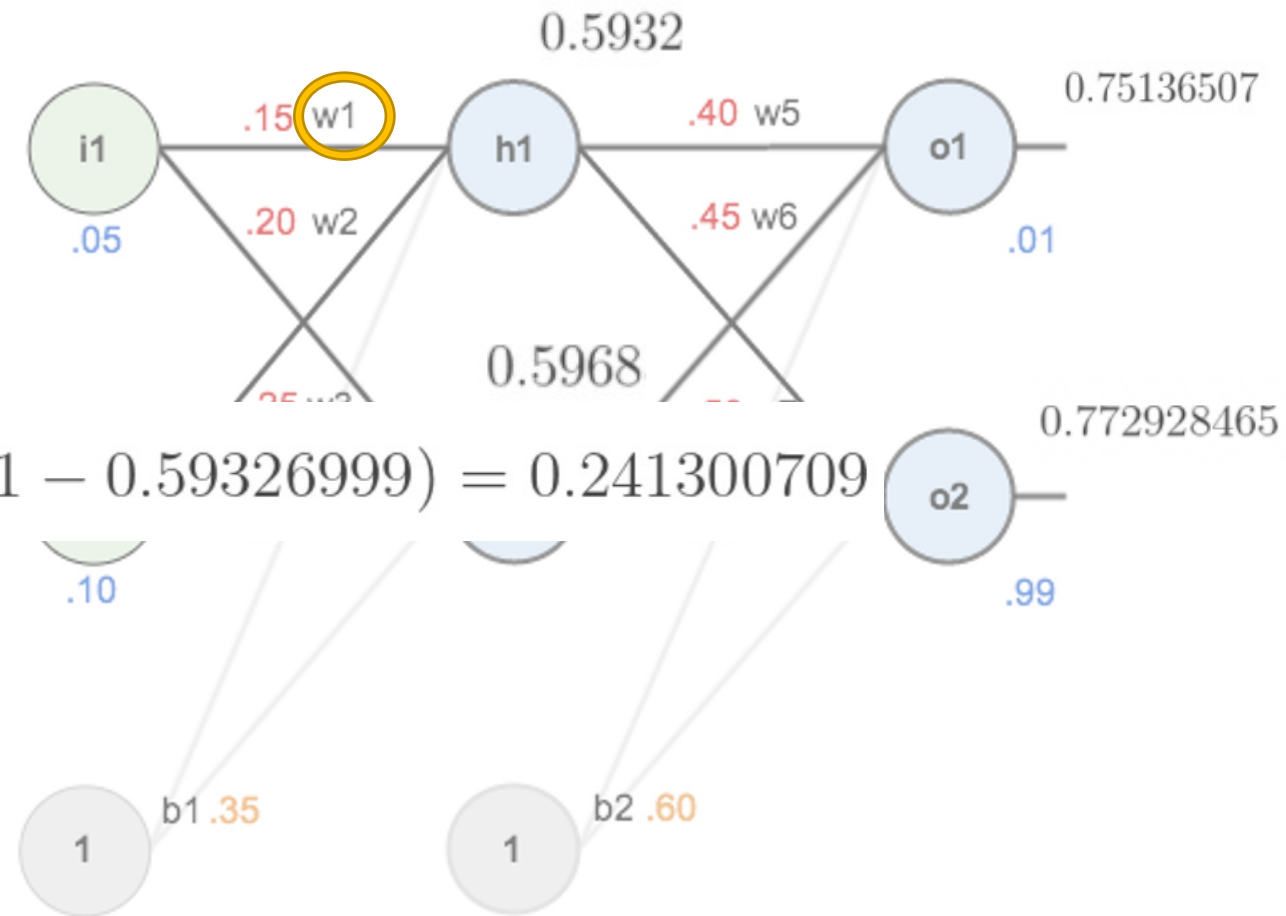

# Example - The Backward Pass ←

$$\frac{\partial E_{total}}{\partial w_1} = \frac{\partial E_{total}}{\partial out_{h1}} * \frac{\partial out_{h1}}{\partial net_{h1}} * \frac{\partial net_{h1}}{\partial w_1}$$

$$net_{h1} = w_1 * i_1 + w_3 * i_2 + b_1 * 1$$

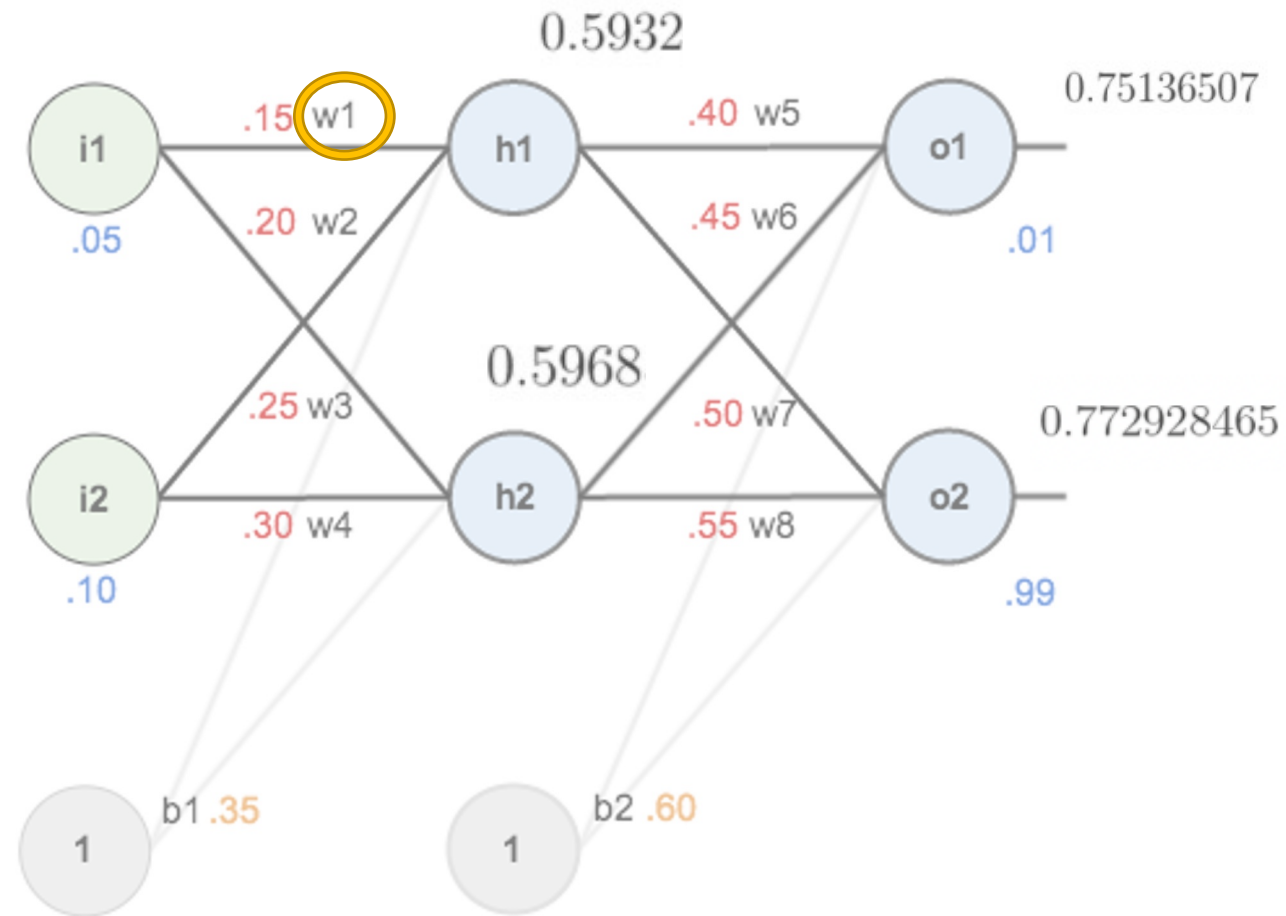

# Example - The Backward Pass ←

$$\frac{\partial E_{total}}{\partial w_1} = \frac{\partial E_{total}}{\partial out_{h1}} * \frac{\partial out_{h1}}{\partial net_{h1}} * \frac{\partial net_{h1}}{\partial w_1}$$

$$net_{h1} = w_1 * i_1 + w_3 * i_2 + b_1 * 1$$

$$\frac{\partial net_{h1}}{\partial w_1} = i_1 = 0.05$$

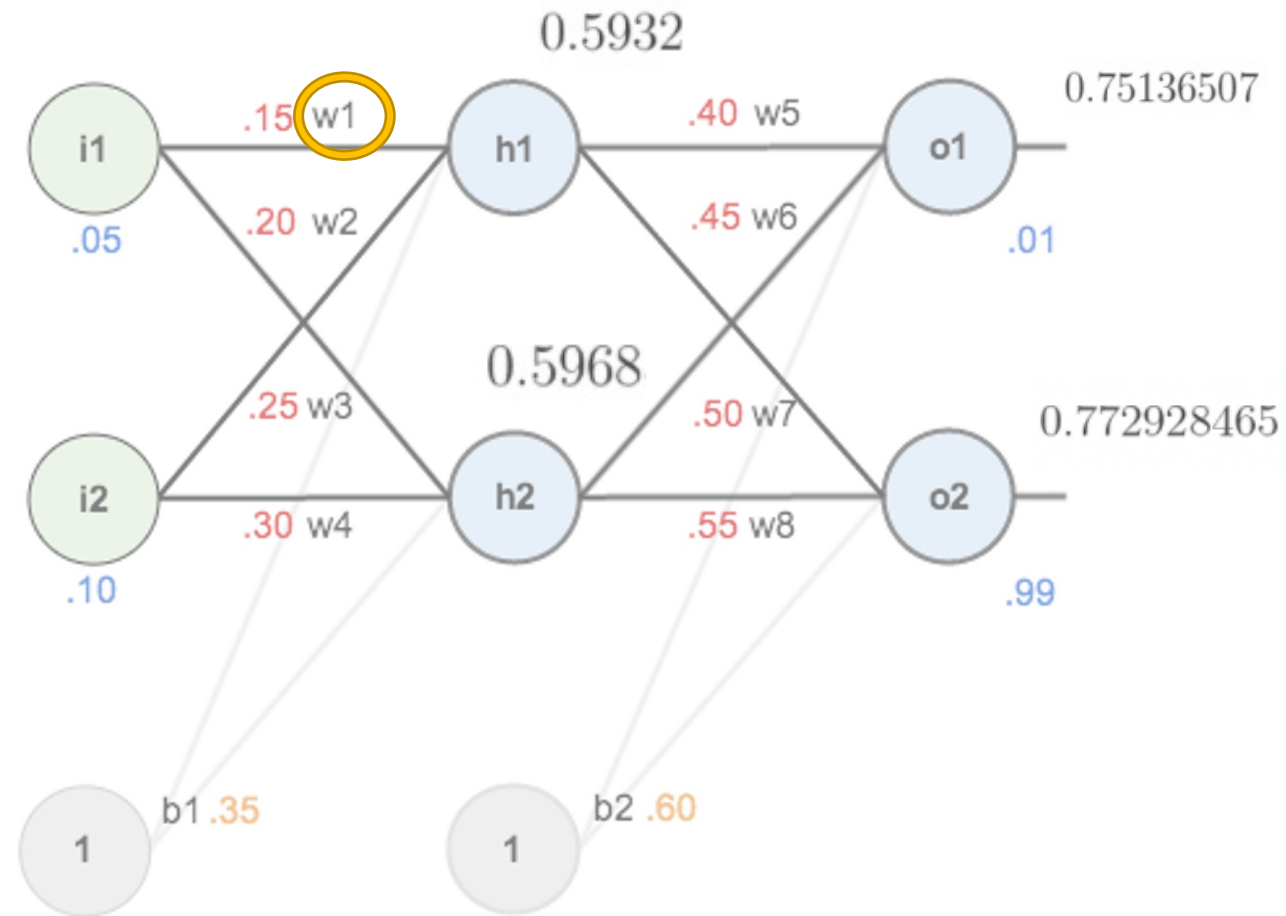

# Example - The Backward Pass ←

$$\frac{\partial E_{total}}{\partial w_1} = \frac{\partial E_{total}}{\partial out_{h1}} * \frac{\partial out_{h1}}{\partial net_{h1}} * \frac{\partial net_{h1}}{\partial w_1}$$

$$\frac{\partial E_{total}}{\partial w_1} = 0.036350306 * 0.241300709 * 0.05 = 0.000438568$$

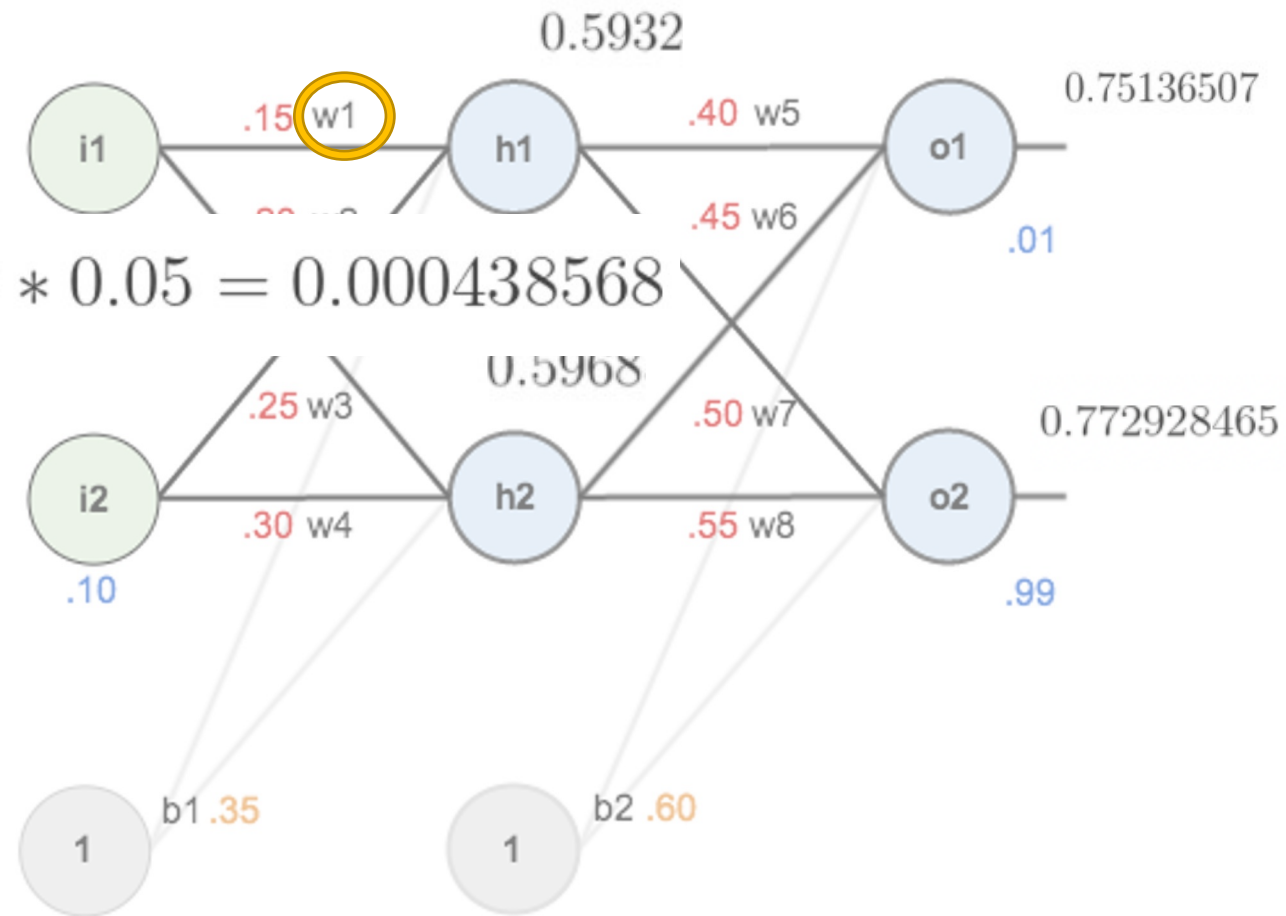



# Example - The Backward Pass ←

$$\frac{\partial E_{total}}{\partial w_1} = \frac{\partial E_{total}}{\partial out_{h1}} * \frac{\partial out_{h1}}{\partial net_{h1}} * \frac{\partial net_{h1}}{\partial w_1}$$

$$\frac{\partial E_{total}}{\partial w_1} = 0.036350306 * 0.241300709 * 0.05 = 0.000438568$$

$$w_1^+ = w_1 - \eta * \frac{\partial E_{total}}{\partial w_1} = 0.15 - 0.5 * 0.000438568 = 0.149780716$$

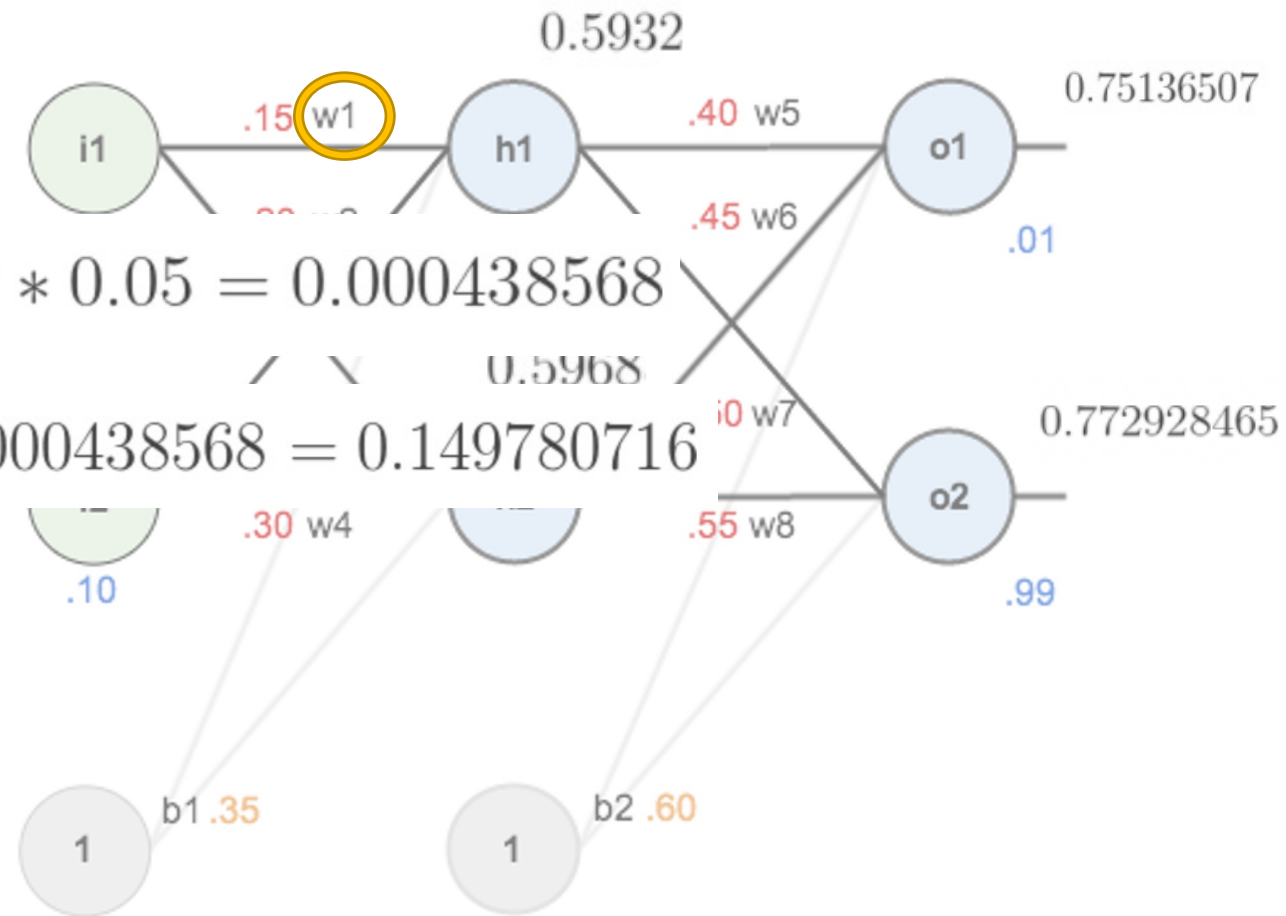

# Backpropagation in other words

- In order to get the loss of a node (e.g. Z0), we multiply the value of its corresponding  $f'(z)$  by the loss of the node it is connected to in the next layer (delta\_1), by the weight of the link connecting both nodes.
- We do the delta calculation step at every unit, back-propagating the loss into the neural net, and finding out what loss every node/unit is responsible for.

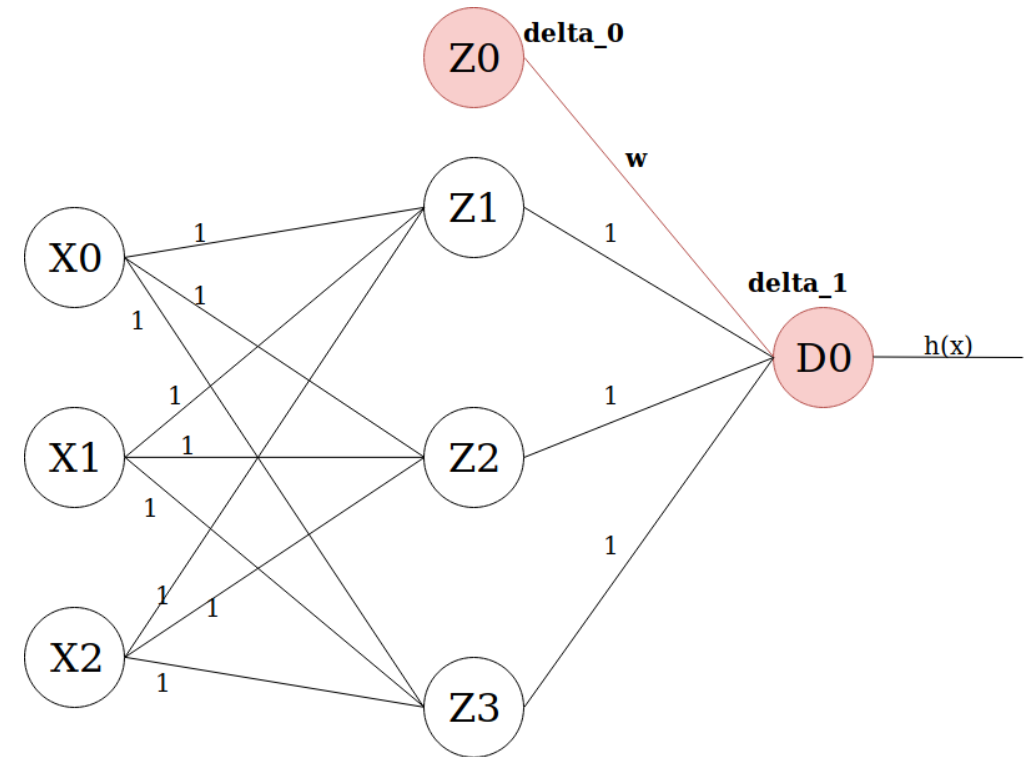

# On the Key Importance of Error Functions

---

- The error/loss/cost function reduces all the various good and bad aspects of a possibly complex system down to a single number, a scalar value, which allows candidate solutions to be compared.
- It is important, therefore, that **the function faithfully represent our design goals.**
- If we choose a poor error function and obtain unsatisfactory results, the fault is ours for badly specifying the goal of the search.

# Objective Functions for NN

- **Regression**: A problem where you predict a real-value quantity.
  - Output Layer: One node with a linear activation unit.
  - Loss Function: Quadratic Loss (Mean Squared Error (MSE))
- **Classification**: Classify an example as belonging to one of K classes
  - Output Layer:
    - One node with a sigmoid activation unit (K=2, binary cross-entropy)
    - K output nodes in a softmax layer (K>2, categorical cross-entropy)\*
  - Loss function: Cross-entropy (i.e. negative log likelihood)

\*When K > 2 the target variable needs to be one-hot encoded

$$J = \sum y^* \log(y)$$

Cross Entropy  
(categorical)

	Forward	Backward
$J = E$ Quadratic	$J = \frac{1}{2}(y - y^*)^2$	$\frac{dJ}{dy} = y - y^*$
Cross Entropy (binary)	$J = y^* \log(y) + (1 - y^*) \log(1 - y)$	$\frac{dJ}{dy} = y^* \frac{1}{y} + (1 - y^*) \frac{1}{y - 1}$

# Design Issues in ANN

---

- Number of nodes in input layer
  - One input node per binary/continuous attribute
  - $k$  or  $\log_2 k$  nodes for each categorical attribute with  $k$  values
- Number of nodes in output layer
  - One output for binary class problem
  - $k$  or  $\log_2 k$  nodes for  $k$ -class problem
- Number of nodes in hidden layer
- Initial weights and biases

# Characteristics of ANN

---

- Multilayer ANN are universal approximators but could suffer from ***overfitting*** if the network is too large.
- Gradient descent may converge to ***local minimum***.
- Model building can be very time consuming, but testing can be very fast.
- Can handle redundant attributes because weights are automatically learnt.
- Sensitive to noise in training data.
- Difficult to handle missing attributes.

# Tips and Tricks of NN Training

---

# Dataset Should Normally be Split Into

---

- ***Training set:*** use to update the weights. Records in this set are repeatedly in random order. The weight update equation are applied after a certain number of records.
- ***Validation set:*** use to decide when to stop training only by monitoring the error and to select the best model configuration
- ***Test set:*** use to test the performance of the neural network. It should not be used as part of the neural network development and model selection cycle



# Before Starting: Weight Initialization

---

- Choice of ***initial weight values is important as this decides starting position in weight space.*** That is, how far away from global minimum
  - Aim is to select weight values which produce midrange function signals
  - Select weight values randomly from uniform probability distribution
  - Normalize weight values so number of weighted connections per unit produces midrange function signal
- Try different random initialization to
  - Assess robustness
  - Have more opportunities to find optimal results

# Two learning fashion (plus one)

---

- **Sequential mode** (on-line, stochastic, or per-pattern)
  - Weights updated after each records is presented
  - Many weight updates, can quicker convergence but also make learning less stable
- **Batch mode** (off-line or per-epoch)
  - Weights updated after all records are presented
  - Can be very slow and lead to trapping in early local minima
- **Minibatch mode** (a blend of the two above)
  - Weights updated after a few records (from tens to thousands) are presented
  - Best of both (and good for GPU)

# Convergence Criteria

---

- Learning is obtained by repeatedly supplying training data and adjusting by backpropagation
  - Typically 1 training set presentation = **1 epoch**
- We need a stopping criteria to define convergence
  - Euclidean norm of the gradient vector reaches a sufficiently small value
  - Absolute rate of change in the average squared error per epoch is sufficiently small
  - **Validation for generalization performance: stop when generalization performance reaches a peak**

# Early Stopping

- Running too many epochs may **overtrain** the network and result in **overfitting** and perform poorly in generalization
- Keep a hold-out validation set and test accuracy after every epoch. Maintain weights for best performing network on the validation set and stop training when error increases beyond this
- Always let the network run for some epochs before deciding to stop (**patience parameter**), then backtrack to best result

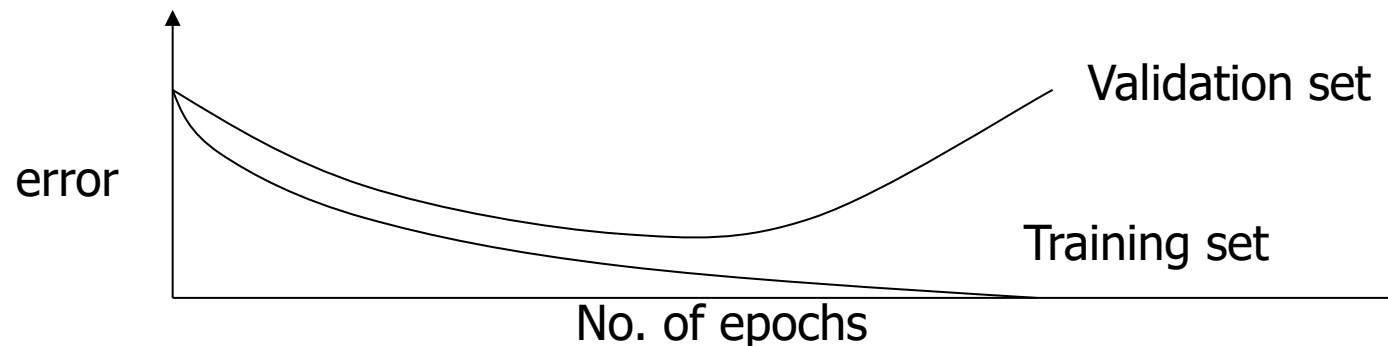

# Model Selection

---

- **Too few hidden units** prevent the network from learning adequately fitting the data and learning the concept.
- **Too many hidden units** leads to overfitting, unless you regularize heavily (e.g. dropout, weight decay, weight penalties)
- Cross validation should be used to determine an appropriate number of hidden units by using the optimal validation error to select the model with optimal number of hidden layers and nodes.

# Regularization

---

- Constrain the learning model to avoid overfitting and help improving generalization.
- Add **penalization terms** to the loss function that *punish* the model for excessive use of resources
  - Limit the **amount of weights** that is used to learn a task
  - Limit the **total activation of neurons** in the network

$$E' = E(y, y^*) + \lambda R(\cdot)$$

Hyperparameter to be  
chosen in model selection

$R(W_\theta)$  Penalty on **parameters**

$R(Z)$  Penalty on **activations**

# Common penalty terms (norms)

---

- 1-norm  $\|A\|_1 = \sum_{ij} |a_{ij}|$ 
  - Parameters:  $R(W_\theta) = \|W_\theta\|_1^2$
  - Activations:  $R(Z(X)) = \|Z(X)\|_1^2$  (Z hidden unit activation)
- 2-norm  $\|A\|_2 = \sqrt{\sum_{ij} a_{ij}^2}$ 
  - Parameters:  $R(W_\theta) = \|W_\theta\|_2^2$
  - Activations:  $R(Z(X)) = \|Z(X)\|_2^2$  (Z hidden unit activation)
- Any p-norm and more...

# Dropout Regularization

---

Randomly disconnect units from the network during training

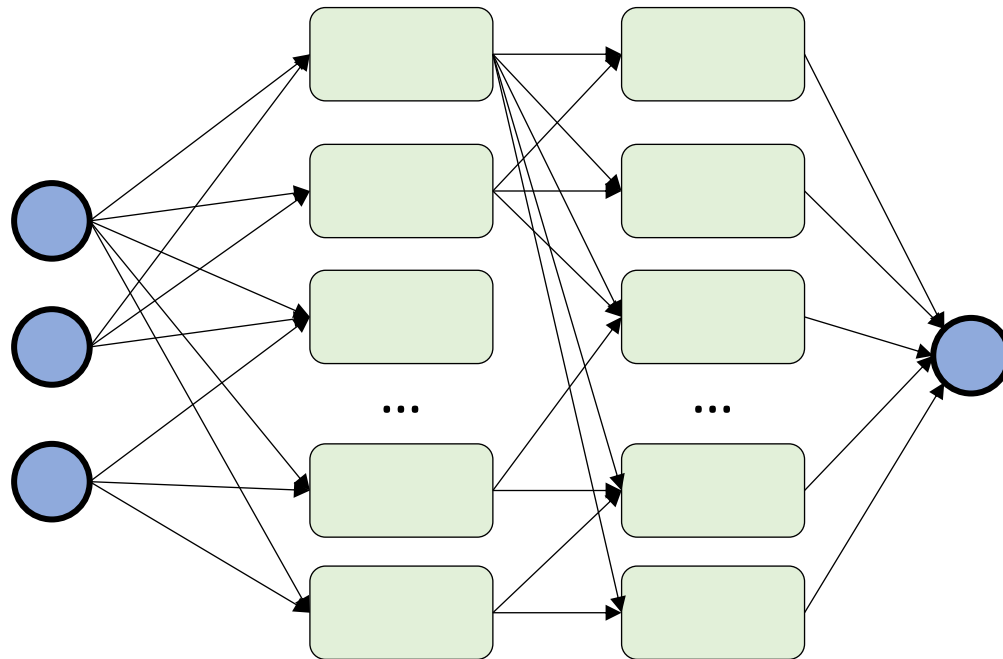



# Dropout Regularization

Randomly disconnect units from the network during training

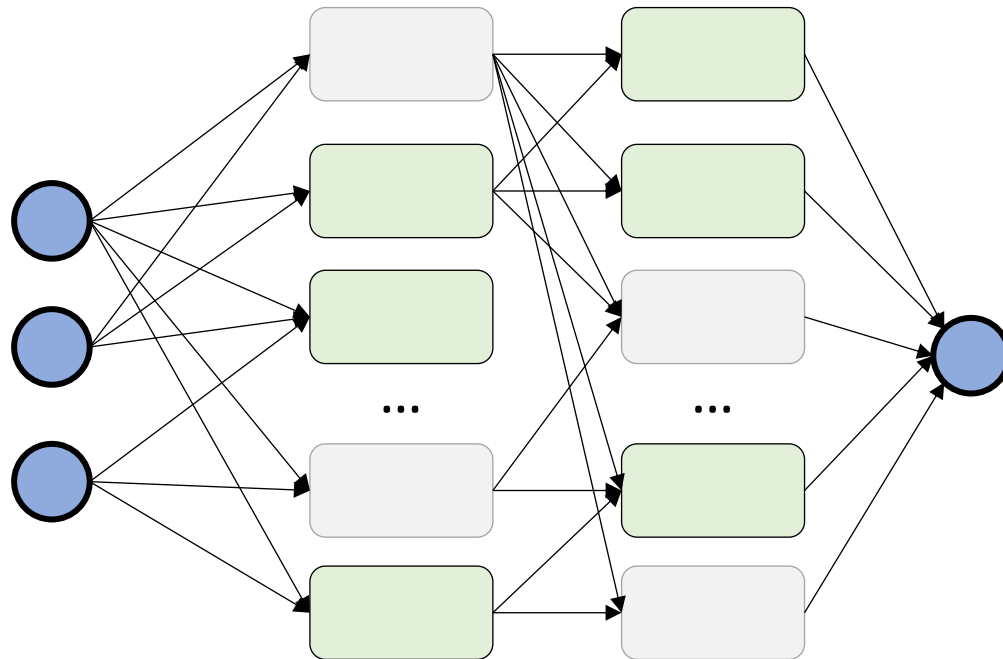

# Dropout Regularization

Randomly disconnect units from the network during training

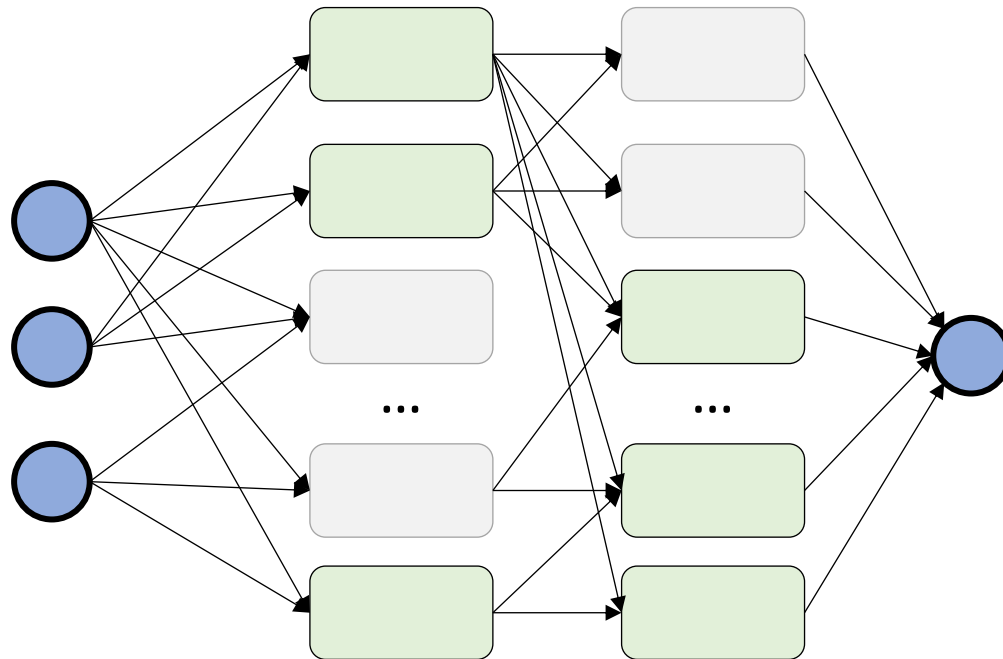

# Dropout Regularization

Randomly disconnect units from the network during training

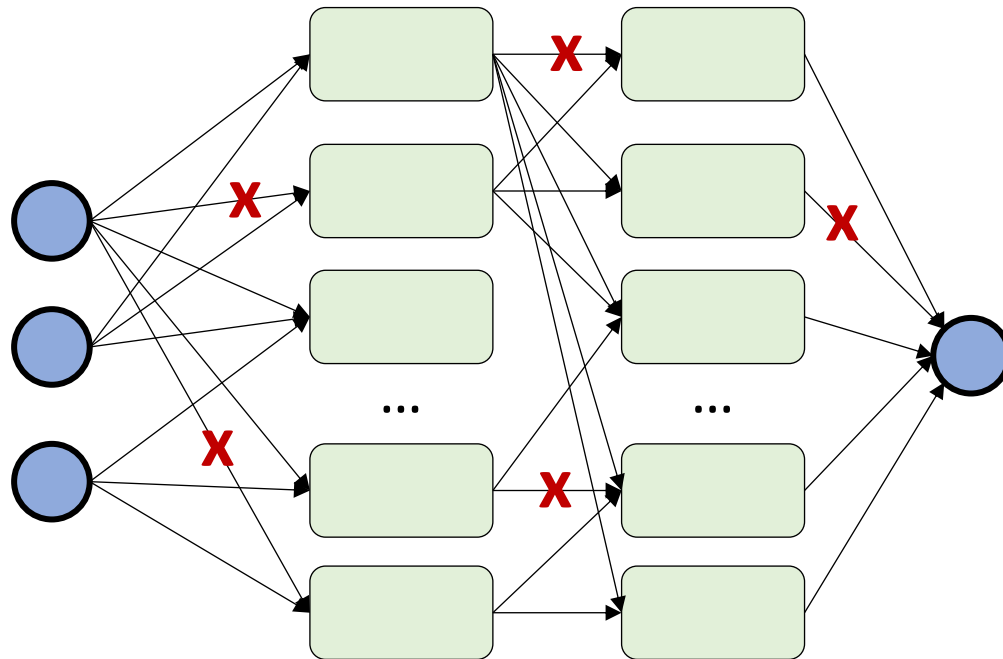

- Regulated by unit **dropping hyperparameter**
- Prevents unit **coadaptation**
- Committee machine effect
- Need to adapt **prediction phase**
- Used at prediction time gives **predictions with confidence intervals**

You can also **drop single connections** (dropconnect)

# Momentum

---

- Adding a term to weight update equation to store an exponentially weight history of previous weights changes
- Reducing problems of instability while increasing the rate of convergence
  - If weight changes tend to have same signs, the momentum term increases and gradient descent speed up convergence on shallow gradient
  - If weight changes tend to have opposing signs, the momentum term decreases and gradient descent slows to reduce oscillations (stabilizes)
  - Can help escape being trapped in local minima

# Choosing the Optimization Algorithm

---

- Standard Stochastic Gradient Descent (SGD)
  - Easy and efficient
  - Difficult to pick up the best learning rate
  - Unstable convergence
  - Often used with **momentum** (exponentially weighted history of previous weights changes)
- RMSprop
  - Adaptive learning rate method (reduces it using a moving average of the squared gradient)
  - Fastens convergence by having quicker gradients when necessary
- Adagrad
  - Like RMSprop with element-wise scaling of the gradient
- **ADAM**
  - Like Adagrad but adds an exponentially decaying average of past gradients like momentum

# Convolutional Neural Networks

- Are typically applied for the classification of images and time series
- Instead of having only “fully connected” layers adopt “convolutional layers”

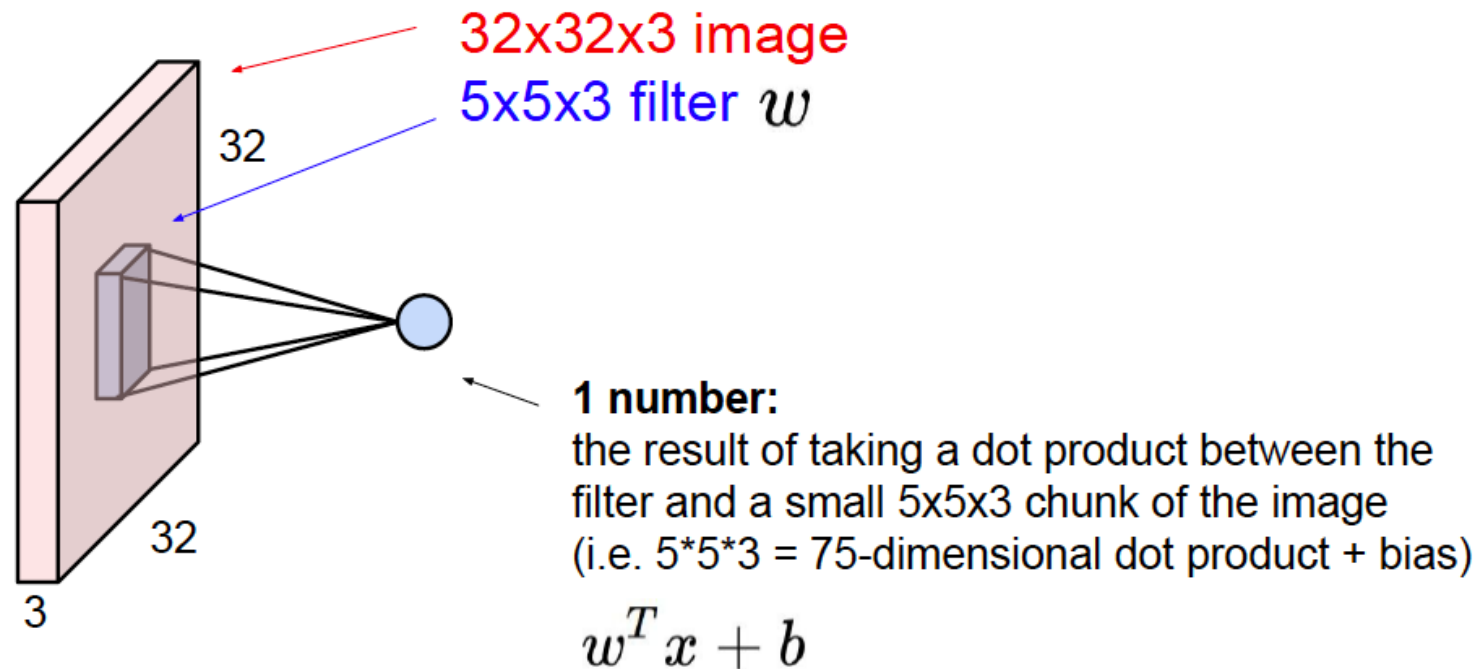

# Recurrent Neural Network

- Are typically applied in natural language processing (NLP).

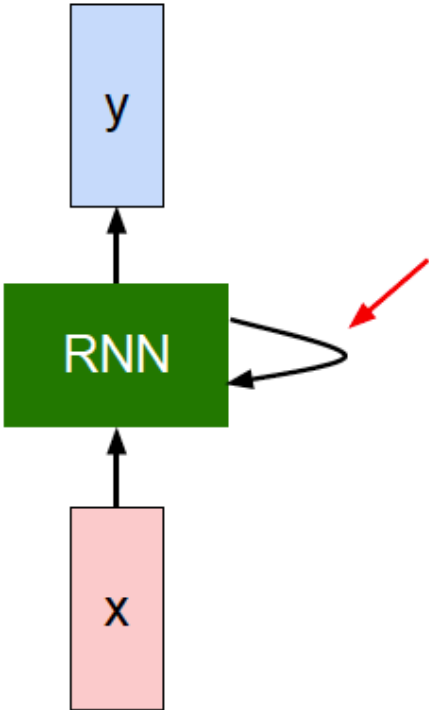

Key idea: RNNs have an "internal state" that is updated as a sequence is processed

$$h_t = f_W(h_{t-1}, x_t)$$

new state     some function with parameters W     old state     input vector at some time step

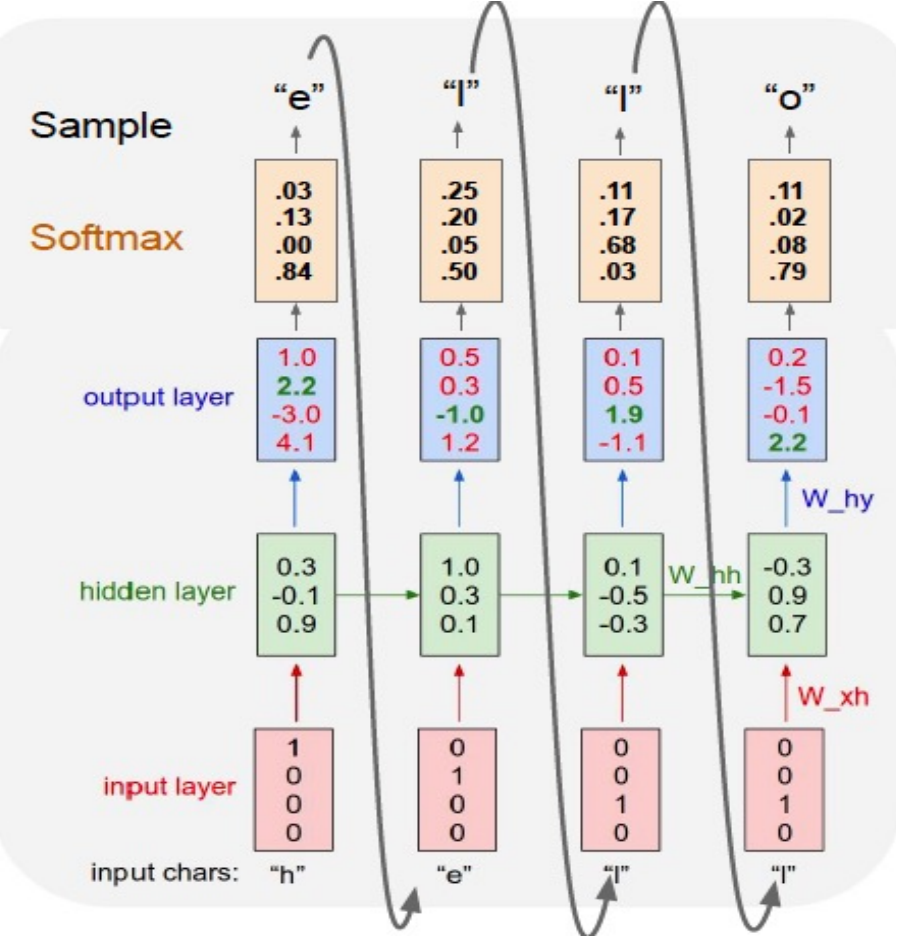

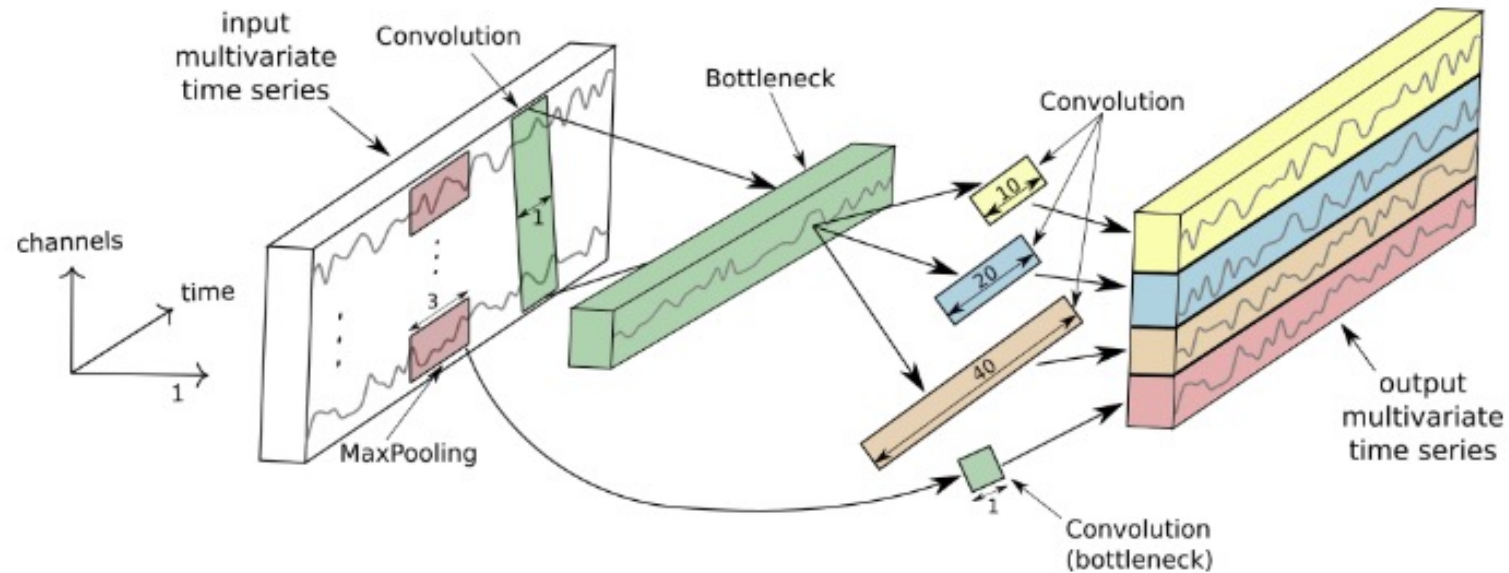

# Convolutional Neural Network

Slides edited from Stanford

[http://cs231n.stanford.edu/slides/2019/cs231n\\_2019\\_lecture09.pdf](http://cs231n.stanford.edu/slides/2019/cs231n_2019_lecture09.pdf)



# Fully Connected Layer

---

32x32x3 image -> stretch to 3072 x 1

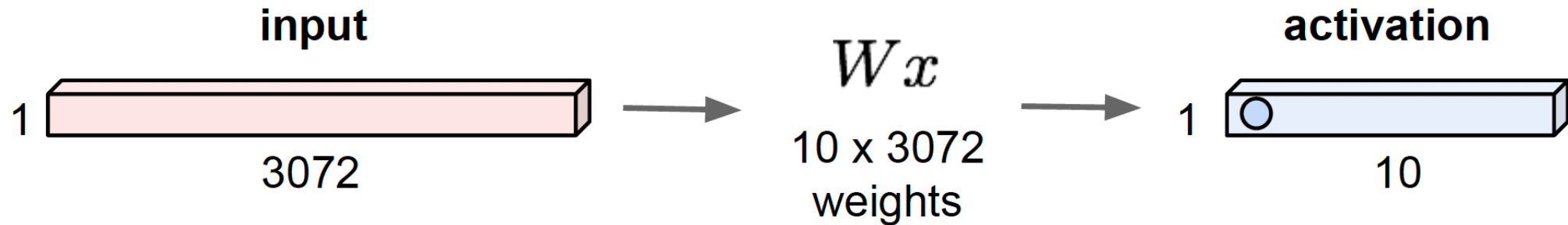

# Fully Connected Layer

32x32x3 image -> stretch to 3072 x 1

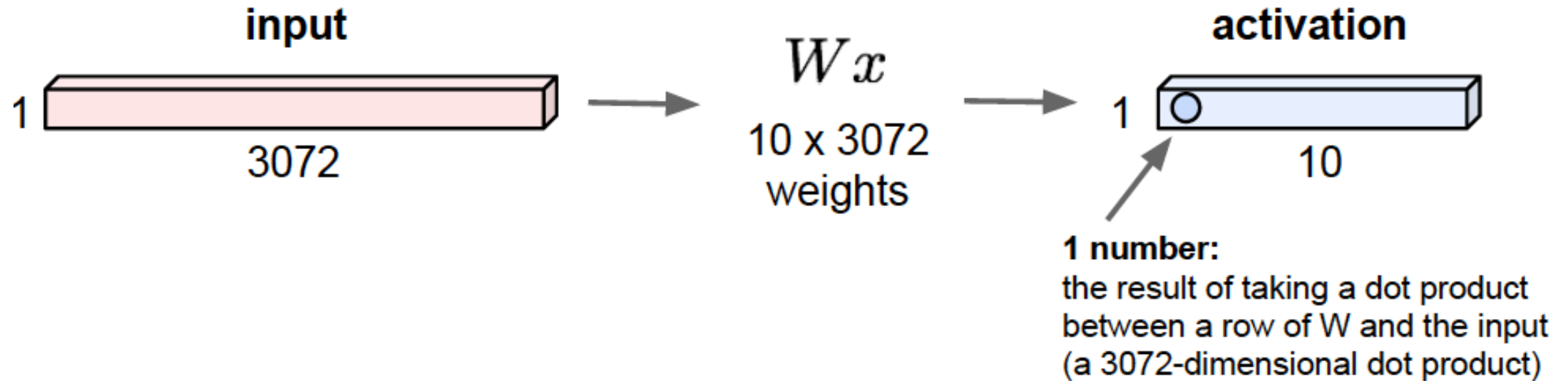

# Convolution Layer

---

32x32x3 image -> preserve spatial structure

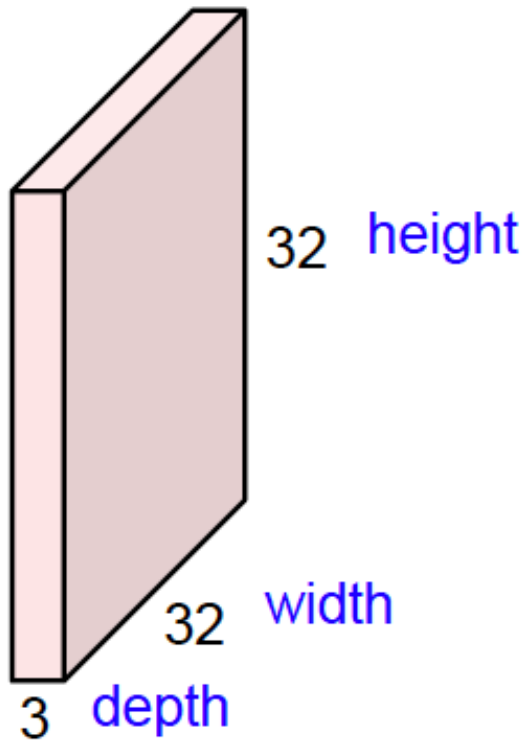

# Convolution Layer

---

32x32x3 image

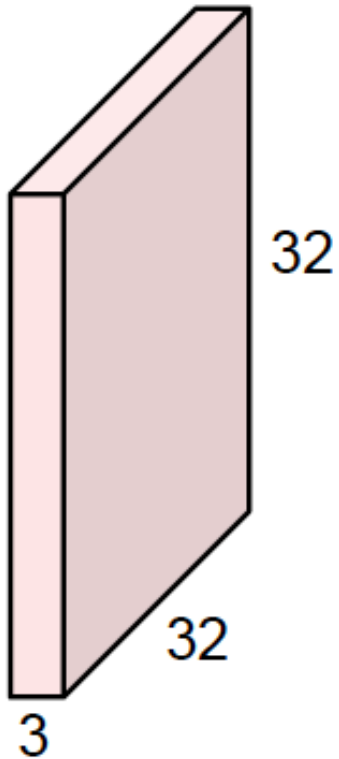

Filters always extend the full depth of the input volume

5x5x3 filter



**Convolve** the filter with the image  
i.e. “slide over the image spatially,  
computing dot products”

# Convolution Layer

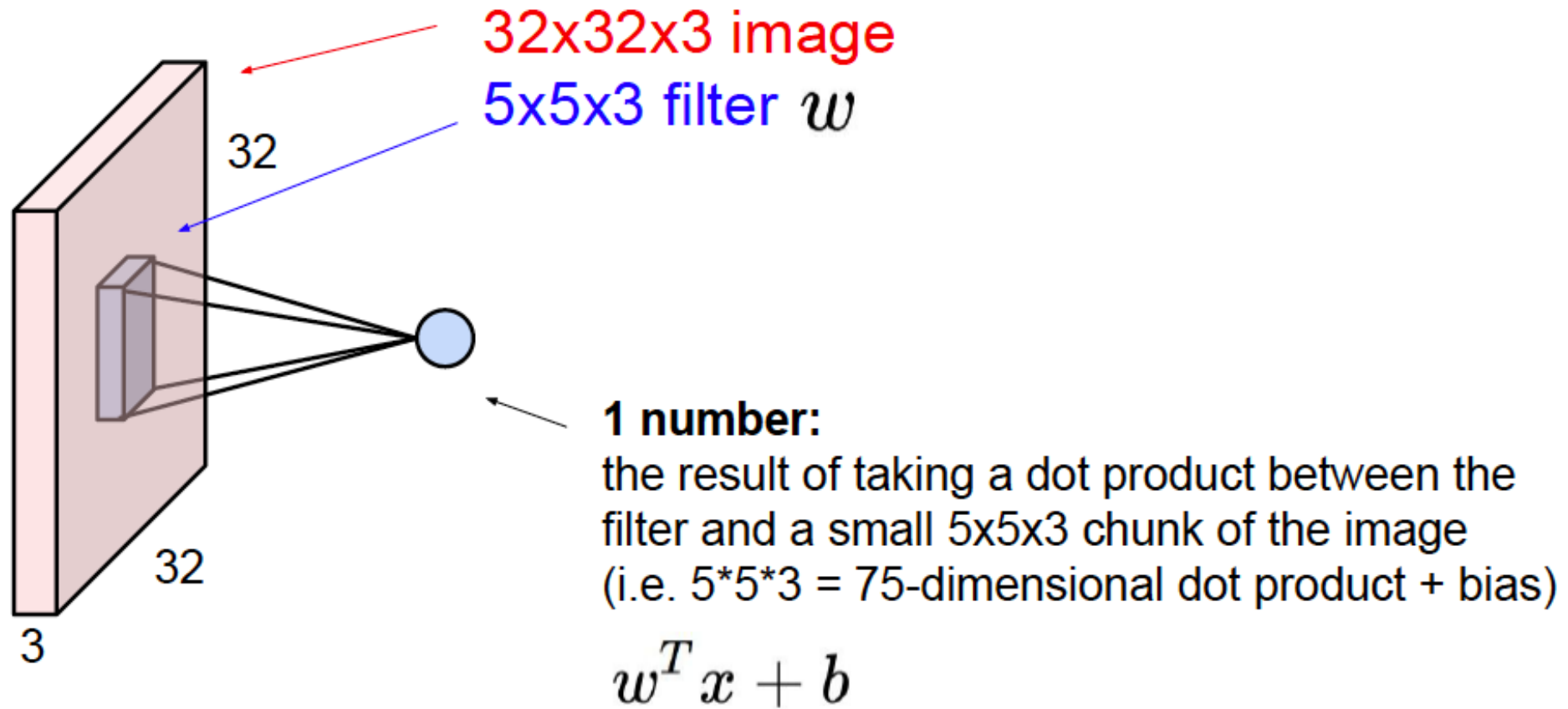

# Convolution Layer

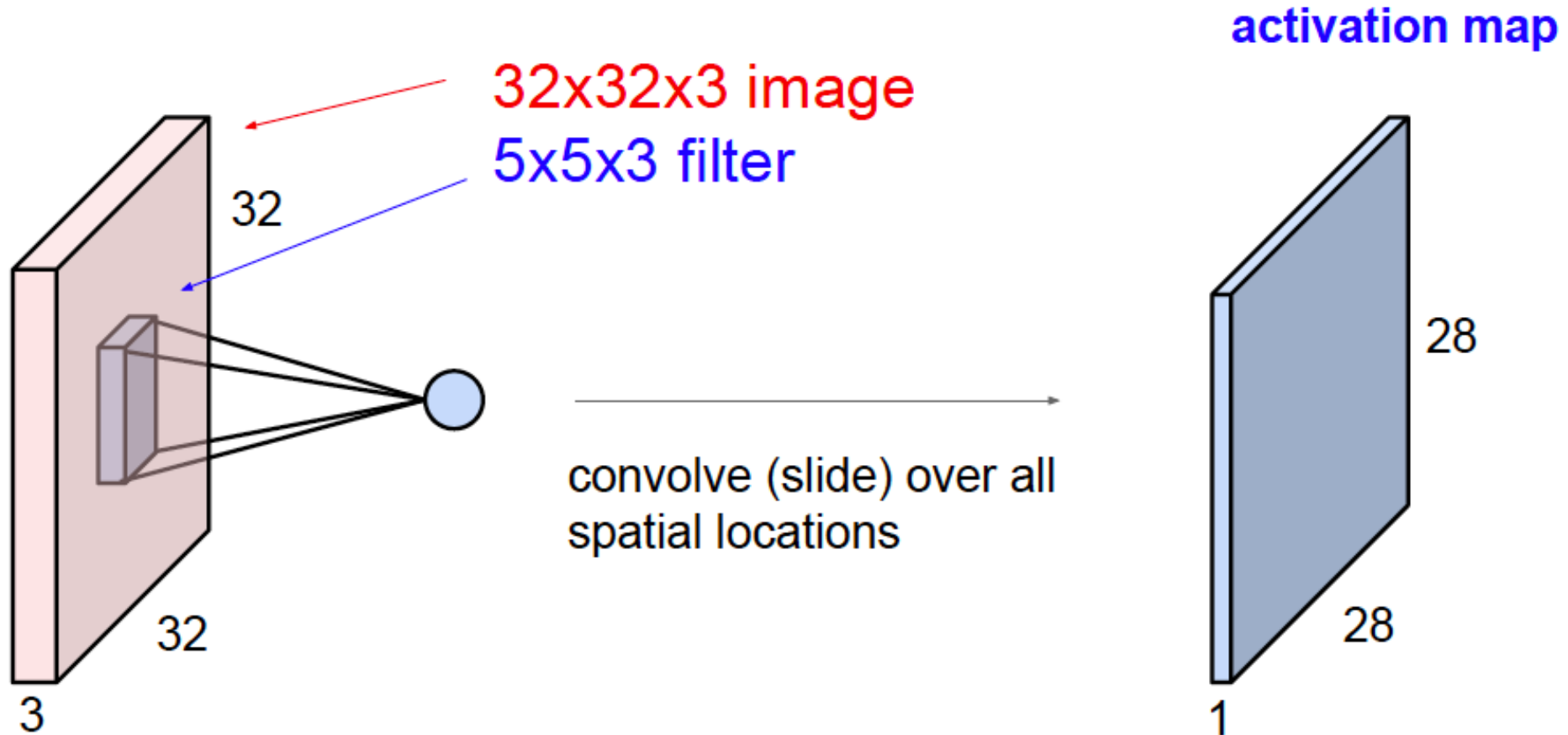

# Convolution Layer

1 <sub>x1</sub>	1 <sub>x0</sub>	1 <sub>x1</sub>	0	0
0 <sub>x0</sub>	1 <sub>x1</sub>	1 <sub>x0</sub>	1	0
0 <sub>x1</sub>	0 <sub>x0</sub>	1 <sub>x1</sub>	1	1
0	0	1	1	0
0	1	1	0	0

Image

4		

Convolved  
Feature

1	0	1
0	1	0
1	0	1

Convolution  
Kernel

# Convolution Layer

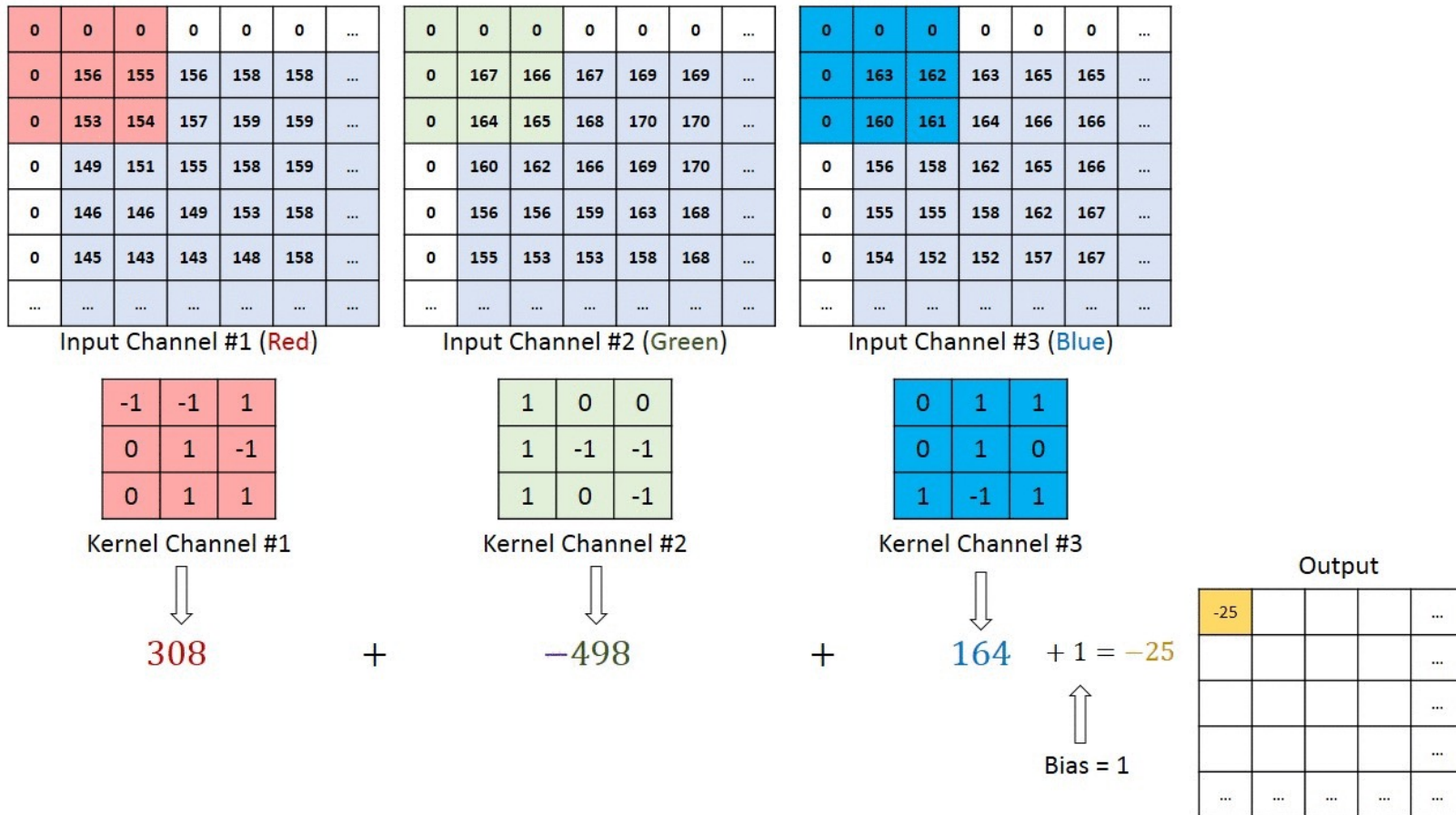



# Convolution Layer

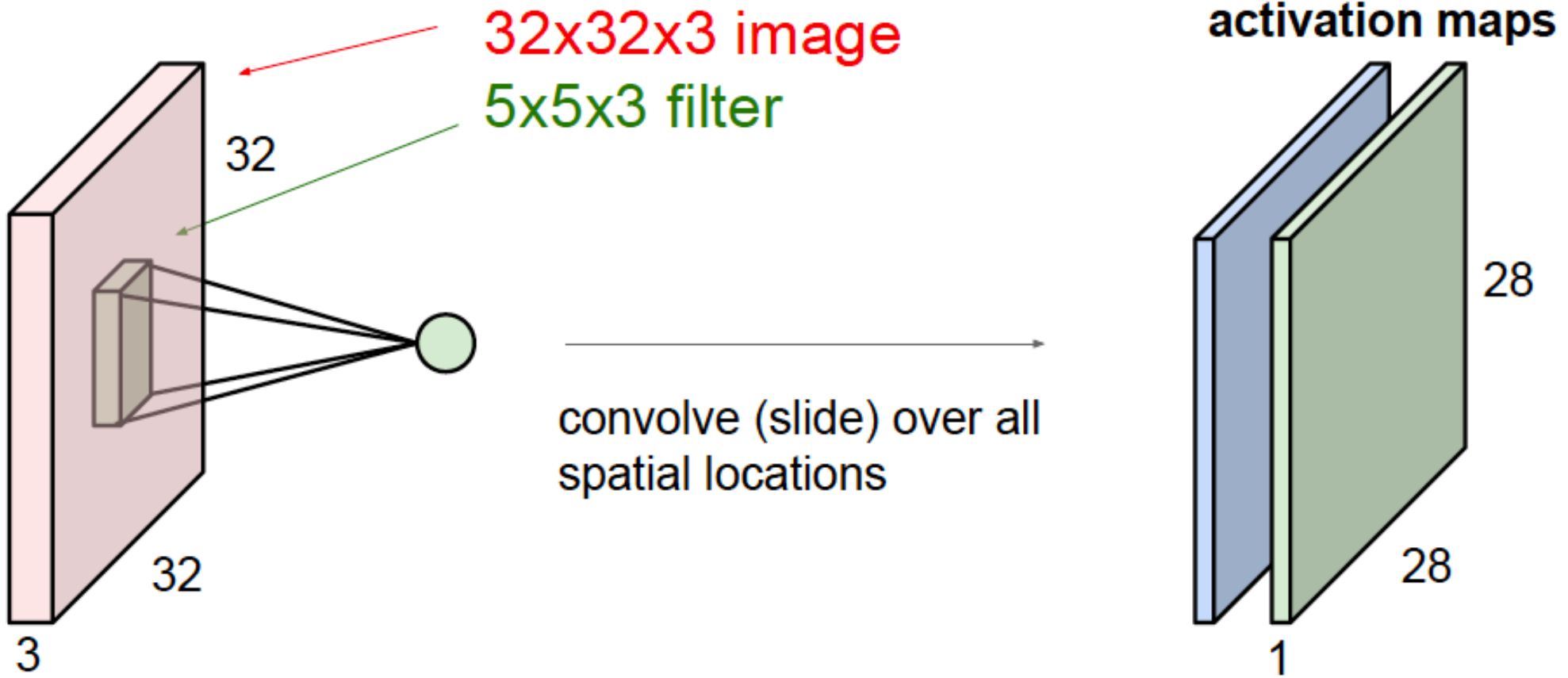

# Convolution Layer

For example, if we had 6 5x5 filters, we'll get 6 separate activation maps:

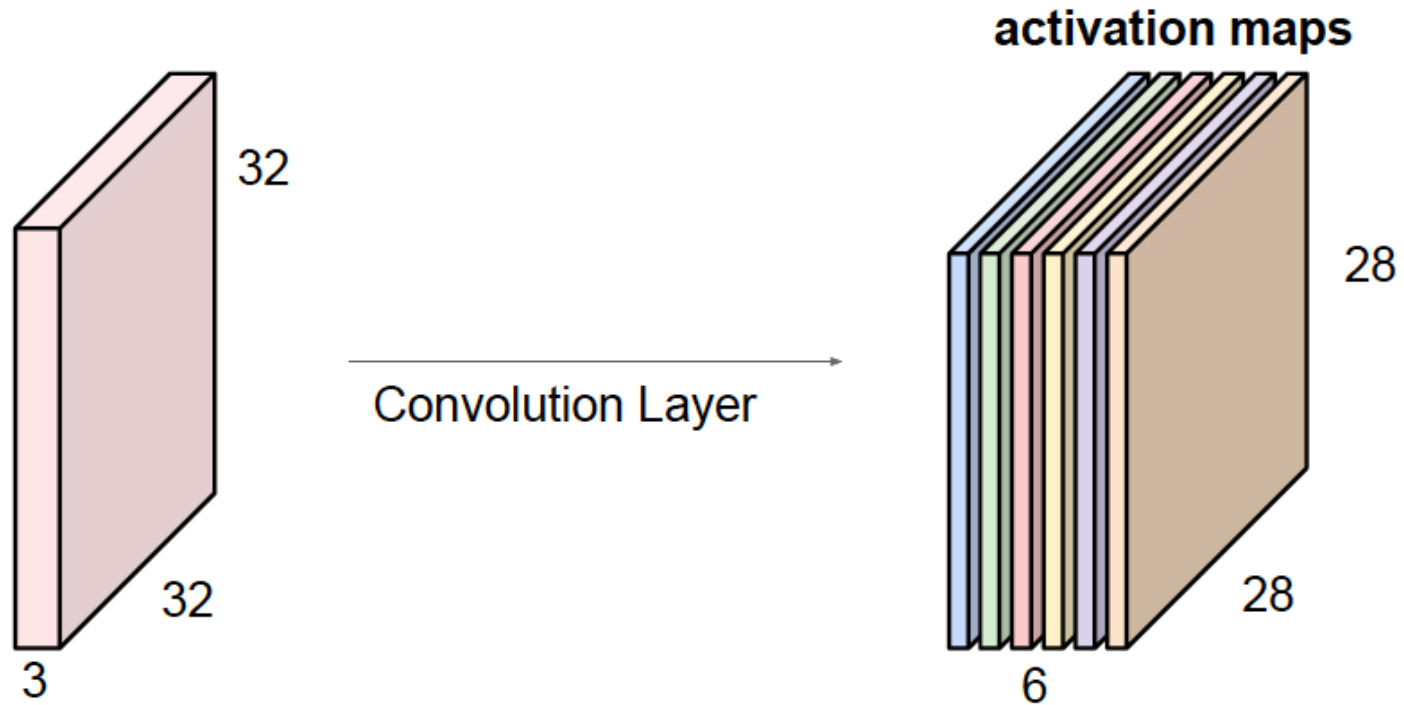

We stack these up to get a “new image” of size 28x28x6!

# Convolutional Neural Network

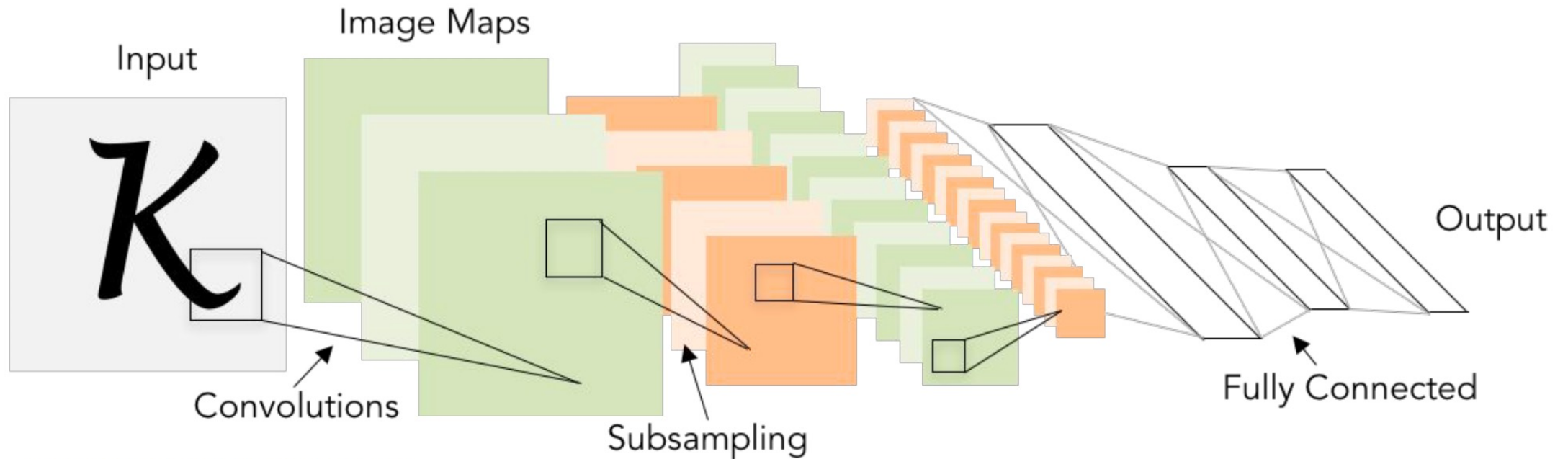
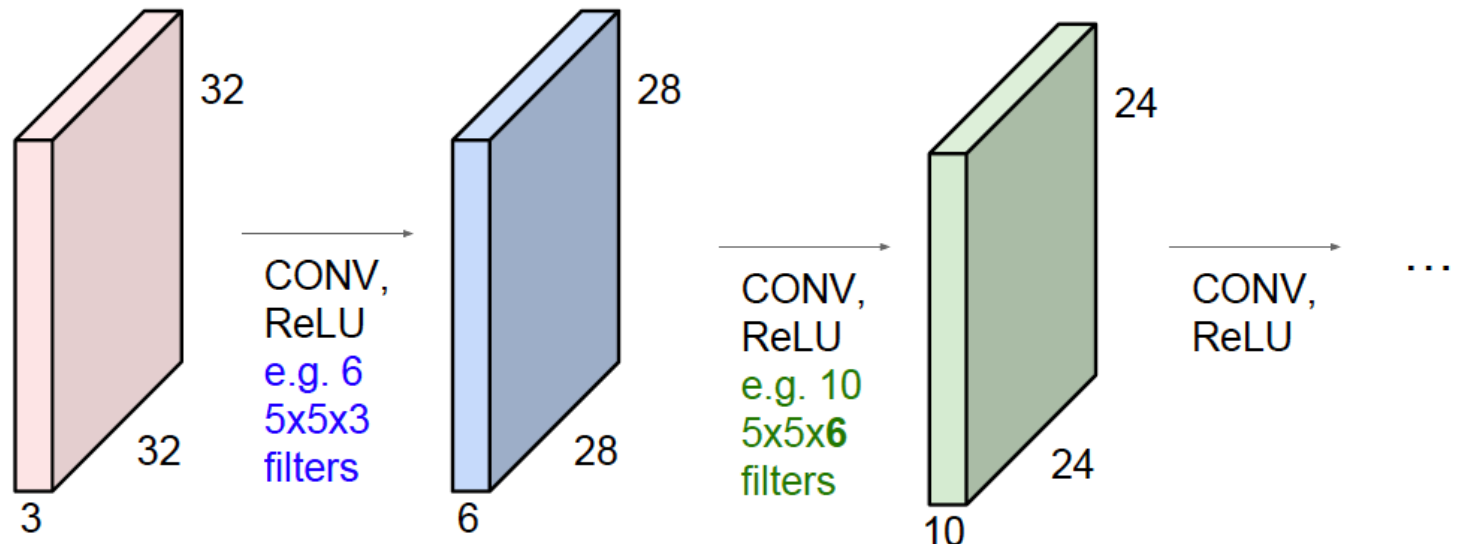

Illustration of LeCun et al. 1998 from CS231n 2017 Lecture 1

# Convolutional Neural Network

- CNN is a sequence of Conv Layers, interspersed with activation functions.
- CNN shrinks volumes spatially.
- E.g. 32x32 input convolved repeatedly with 5x5 filters! (32 -> 28 -> 24 ...).
- Shrinking too fast is not good, doesn't work well.



# CNN for Image Classification

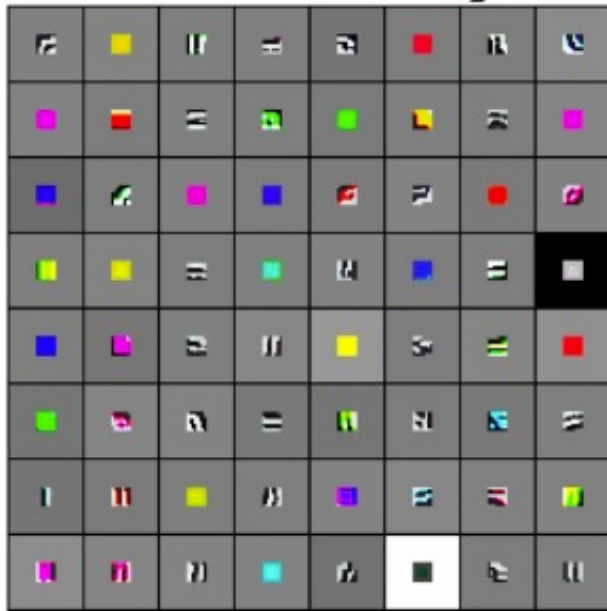

VGG-16 Conv1\_1

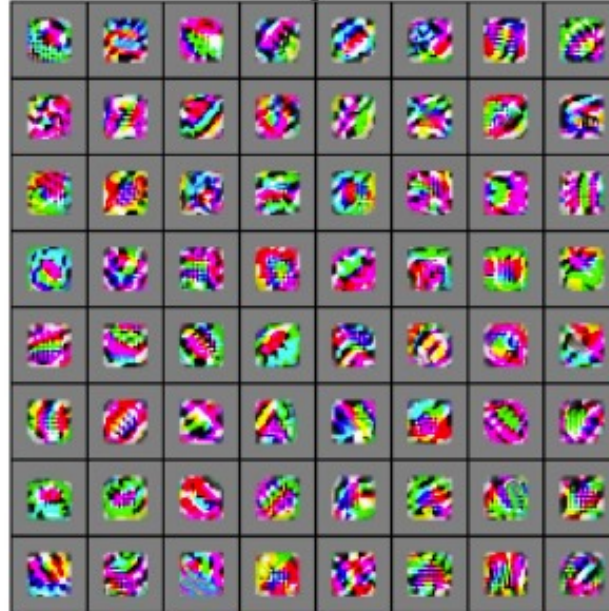

VGG-16 Conv3\_2

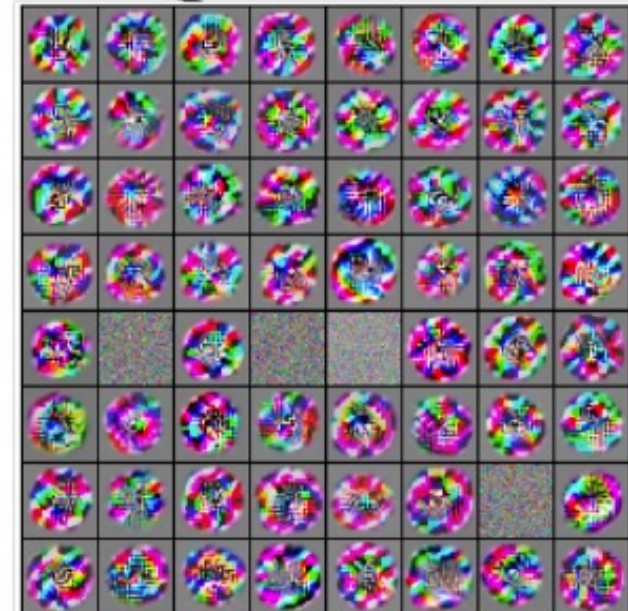

VGG-16 Conv5\_3

# Stride

---

7

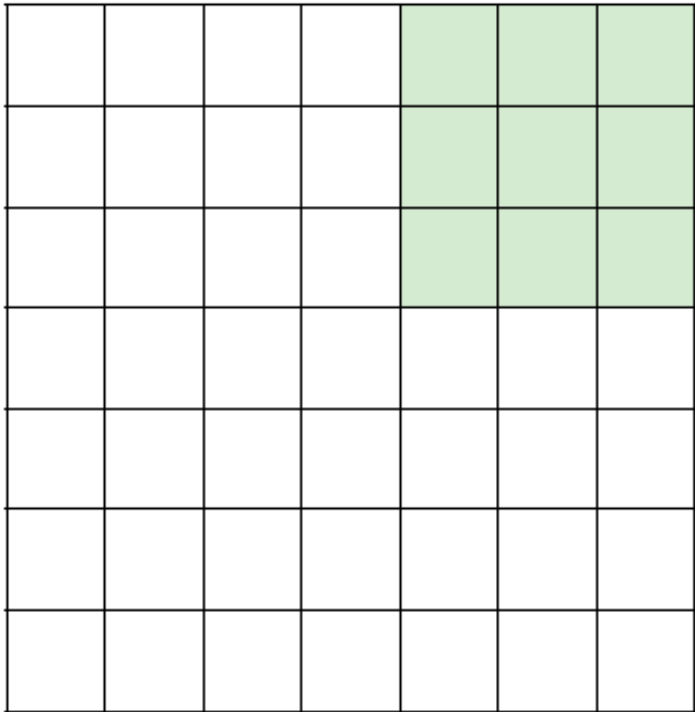

7x7 input (spatially)  
assume 3x3 filter

**=> 5x5 output**

7

# Stride

---

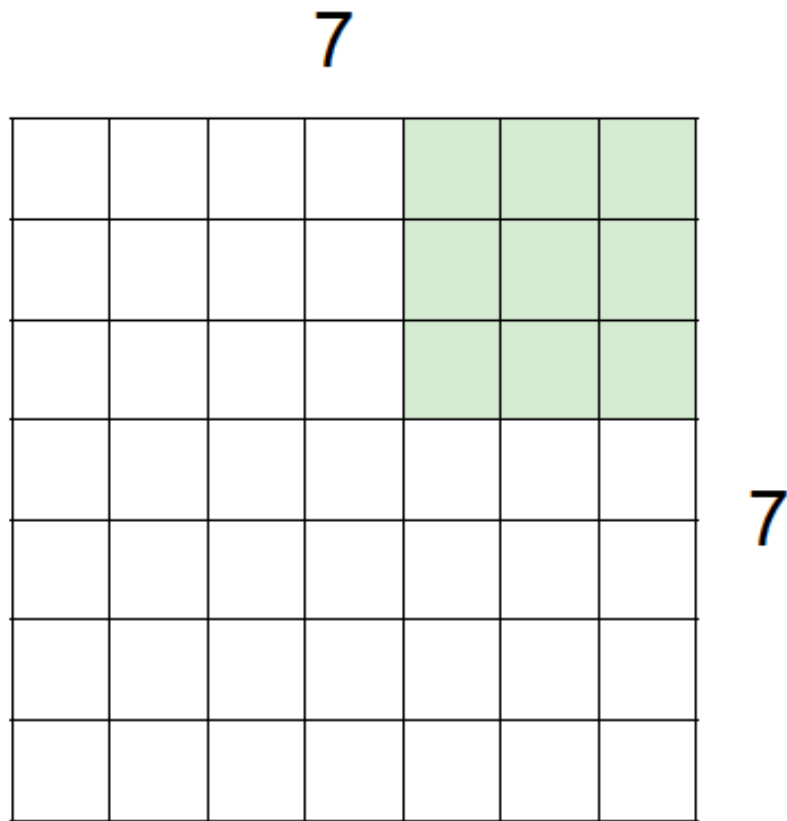

7x7 input (spatially)  
assume 3x3 filter  
applied **with stride 2**  
**=> 3x3 output!**

# Stride

---

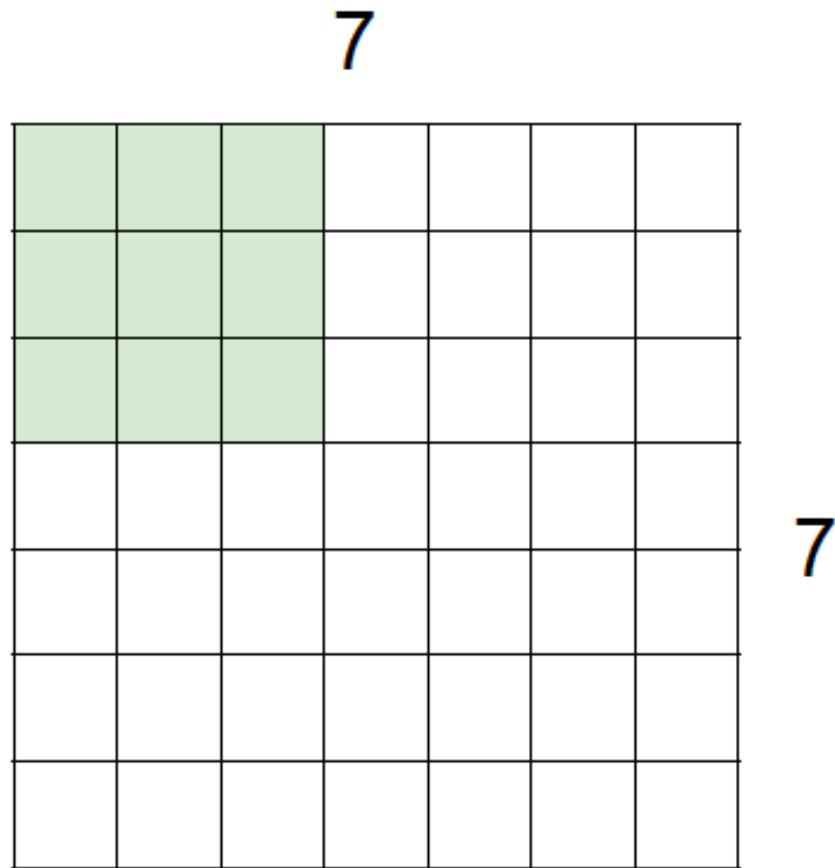

7x7 input (spatially)  
assume 3x3 filter  
applied **with stride 3?**

**doesn't fit!**  
cannot apply 3x3 filter on  
7x7 input with stride 3.



# Stride

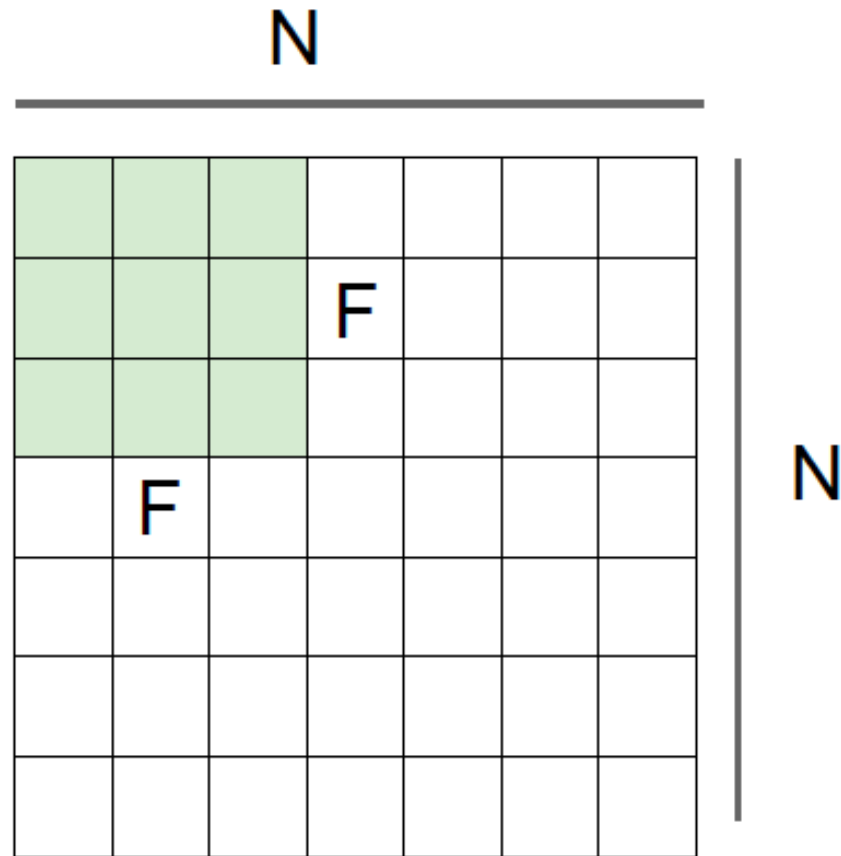

Output size:

$$(N - F) / \text{stride} + 1$$

e.g.  $N = 7$ ,  $F = 3$ :

$$\text{stride } 1 \Rightarrow (7 - 3) / 1 + 1 = 5$$

$$\text{stride } 2 \Rightarrow (7 - 3) / 2 + 1 = 3$$

$$\text{stride } 3 \Rightarrow (7 - 3) / 3 + 1 = 2.33 \text{ :}\backslash$$

# Padding

0	0	0	0	0	0			
0								
0								
0								
0								

e.g. input 7x7

**3x3** filter, applied with **stride 1**

**pad with 1 pixel** border => what is the output?

**7x7 output!**

In general, common to see CONV layers with stride 1, filters of size  $F \times F$ , and zero-padding with  $(F-1)/2$ .  
(will preserve size spatially)

- $F = 3 \Rightarrow$  zero pad with 1 pixel
- $F = 5 \Rightarrow$  zero pad with 2 pixel
- $F = 7 \Rightarrow$  zero pad with 3 pixel

# Convolution Summary

---

- Accepts a volume of size  $W_1 \times H_1 \times D_1$
- Requires four hyperparameters:
  - Number of filters  $K$ ,
  - their spatial extent  $F$ ,
  - the stride  $S$ ,
  - the amount of zero padding  $P$ .
- Produces a volume of size  $W_2 \times H_2 \times D_2$  where:
  - $W_2 = (W_1 - F + 2P)/S + 1$
  - $H_2 = (H_1 - F + 2P)/S + 1$  (i.e. width and height are computed equally by symmetry)
  - $D_2 = K$
- With parameter sharing, it introduces  $F \cdot F \cdot D_1$  weights per filter, for a total of  $(F \cdot F \cdot D_1) \cdot K$  weights and  $K$  biases.
- In the output volume, the  $d$ -th depth slice (of size  $W_2 \times H_2$ ) is the result of performing a valid convolution of the  $d$ -th filter over the input volume with a stride of  $S$ , and then offset by  $d$ -th bias.

# Pooling Layer

- Makes the representations smaller and more manageable
- Operates over each activation map independently

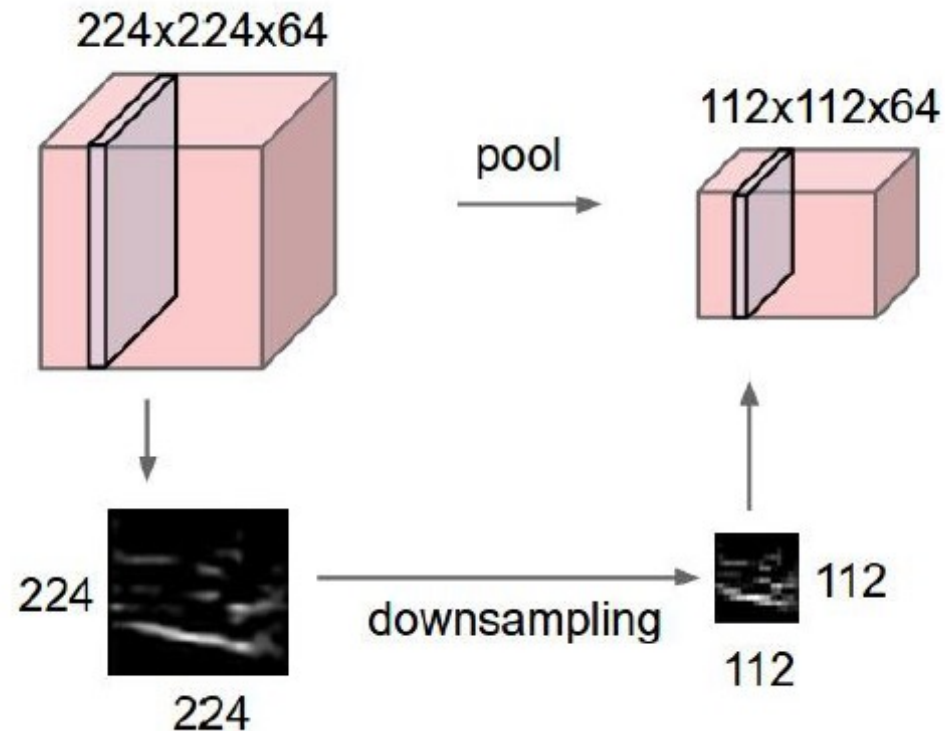

# MaxPooling and AvgPoling

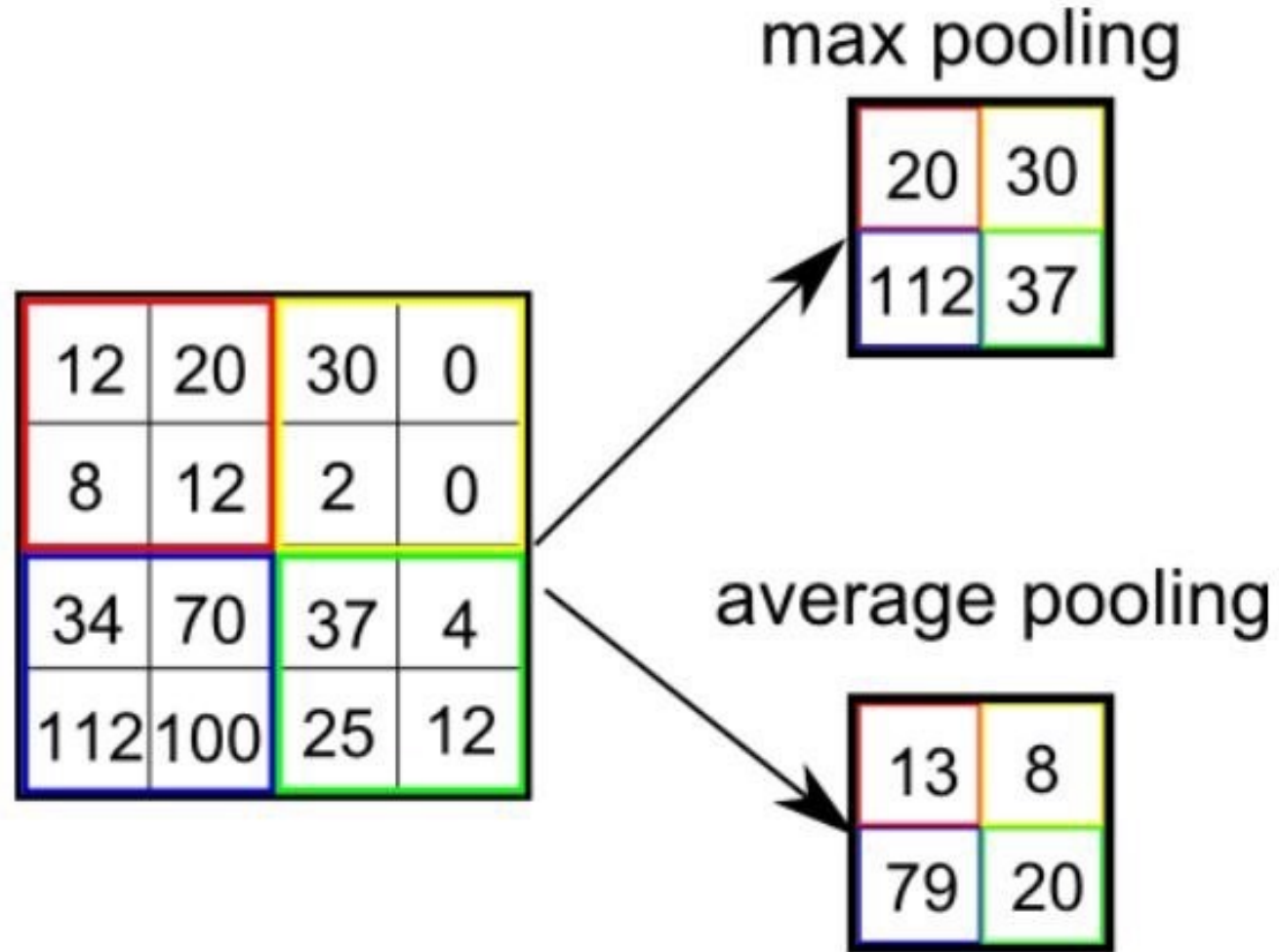

# Pooling Summary

---

- Accepts a volume of size  $W_1 \times H_1 \times D_1$
- Requires three hyperparameters:
  - their spatial extent  $F$ ,
  - the stride  $S$ ,
- Produces a volume of size  $W_2 \times H_2 \times D_2$  where:
  - $W_2 = (W_1 - F) / S + 1$
  - $H_2 = (H_1 - F) / S + 1$
  - $D_2 = D_1$
- Introduces zero parameters since it computes a fixed function of the input
- Note that it is not common to use zero-padding for Pooling layers

# Example of CNN

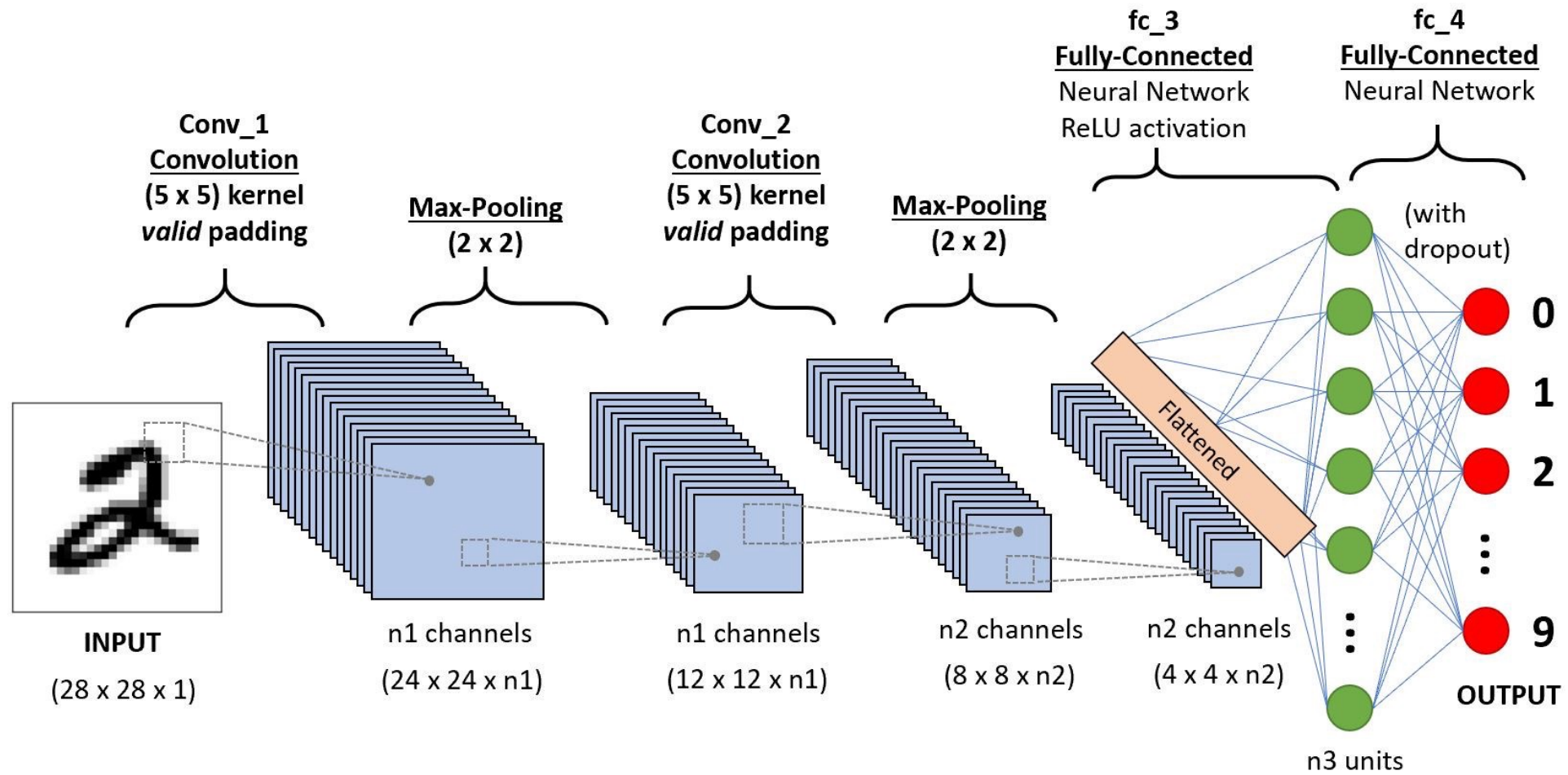

# Recurrent Neural Network

---

Slides edited from Stanford

[http://cs231n.stanford.edu/slides/2019/cs231n\\_2019\\_lecture10.pdf](http://cs231n.stanford.edu/slides/2019/cs231n_2019_lecture10.pdf)



# Types of Recurrent Neural Networks

one to one

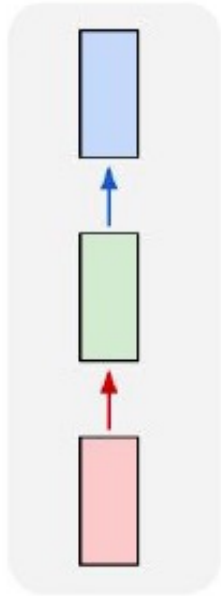

Vanilla NN

one to many

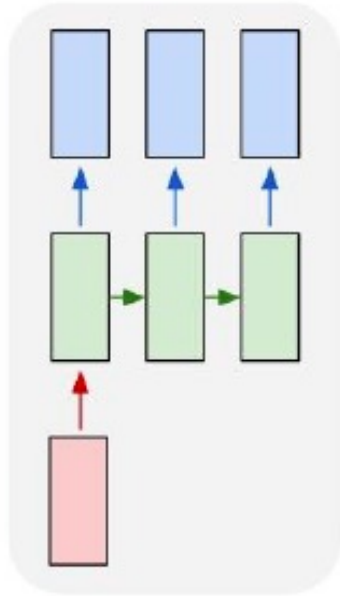
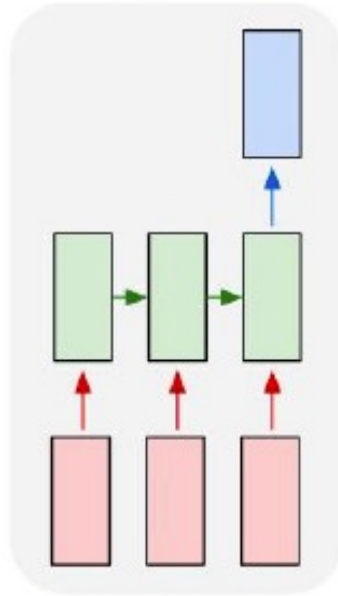

Image -->  
Sequence of Words  
Image Captioning

many to one



Sequence of Words -->  
Sentiment  
Sentiment Classification  
TS Classification

many to many

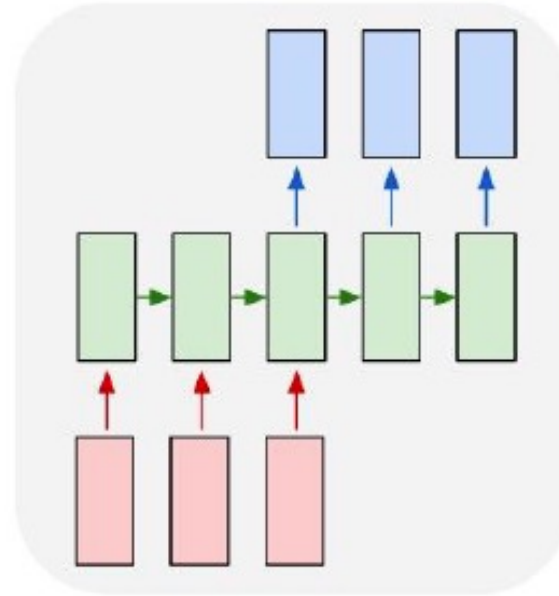

Sequence of Words -->  
Sequence of Words  
Machine Translation

many to many

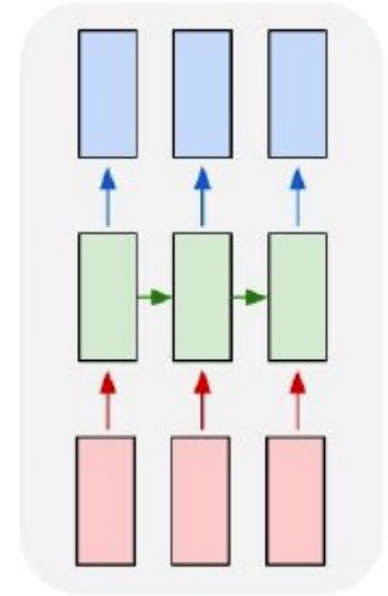

Video Classification

# Recurrent Neural Network - RNN

---

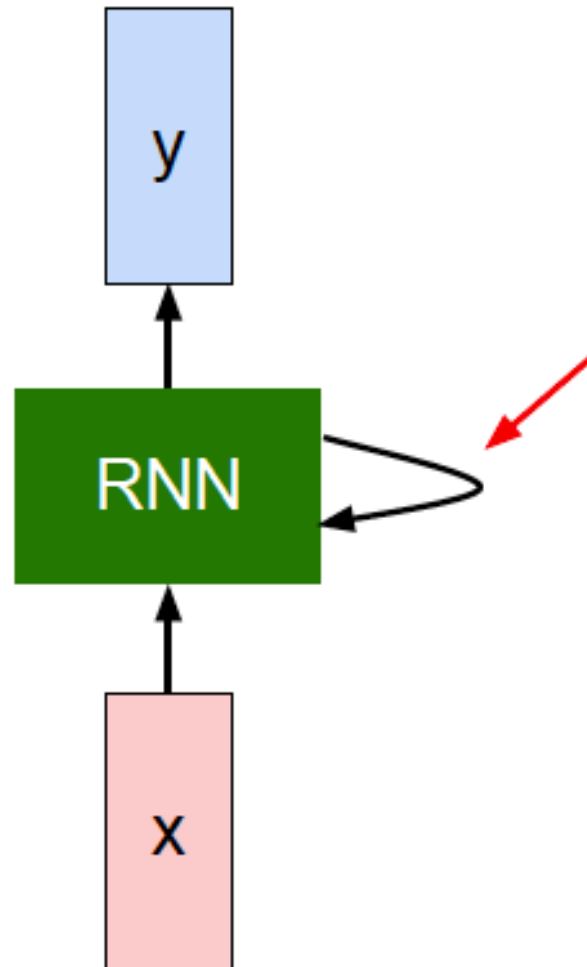

Key idea: RNNs have an “internal state” that is updated as a sequence is processed

# Recurrent Neural Network - RNN

- We can process a sequence of vectors  $\mathbf{x}$  by applying a *recurrence formula* at every time step:

$$\boxed{h_t} = \boxed{f_W}(\boxed{h_{t-1}}, \boxed{x_t})$$

new state / some function with parameters  $W$

old state

input vector at some time step

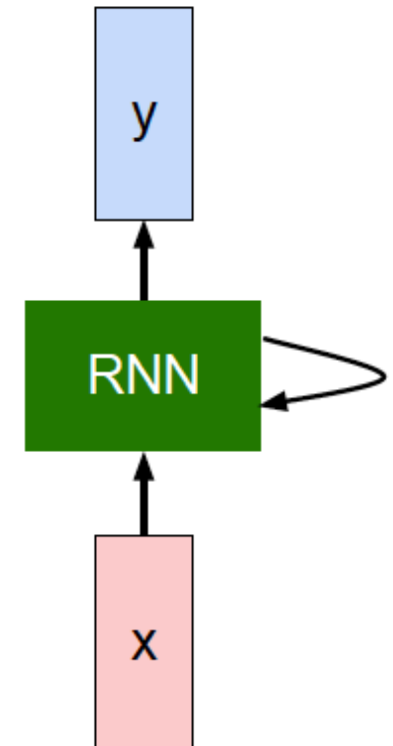

# Unfolded RNN

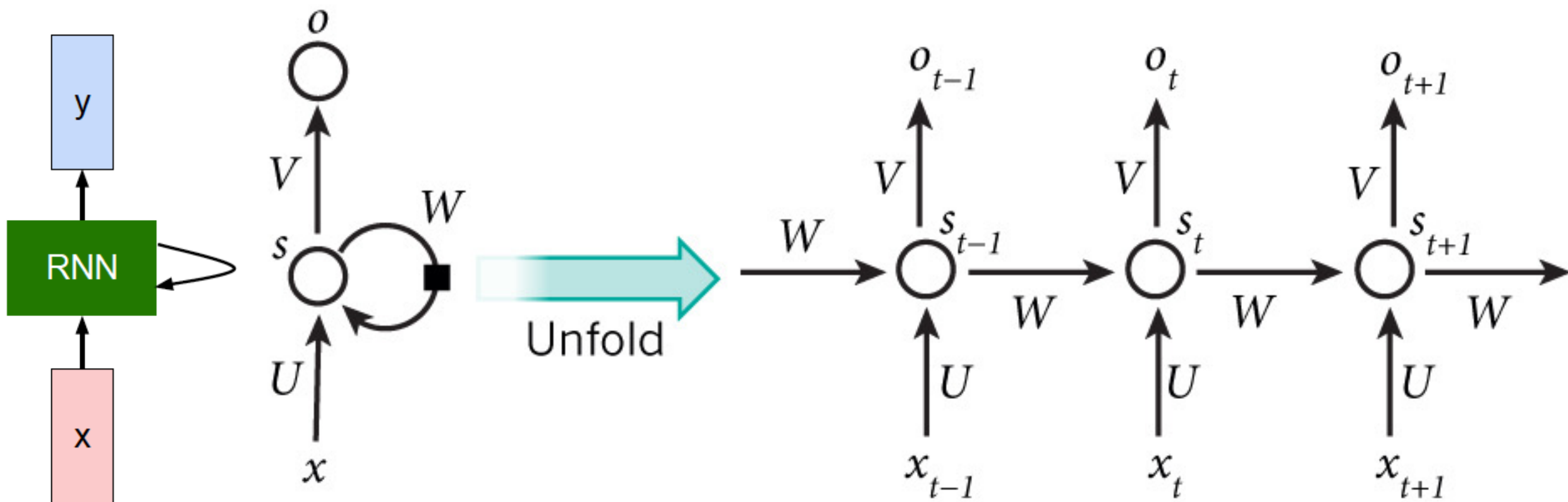

# RNN: Computational Graph

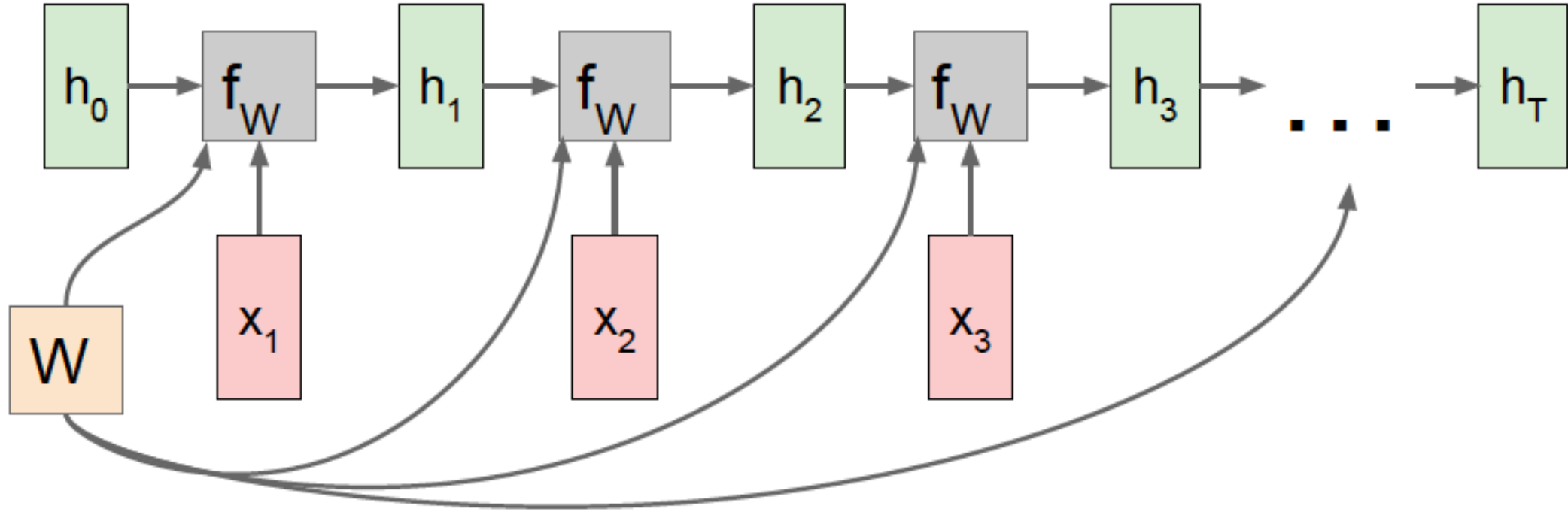

Reminder: Re-use the same weight matrix at every time-step

# RNN: Computational Graph: Many to Many

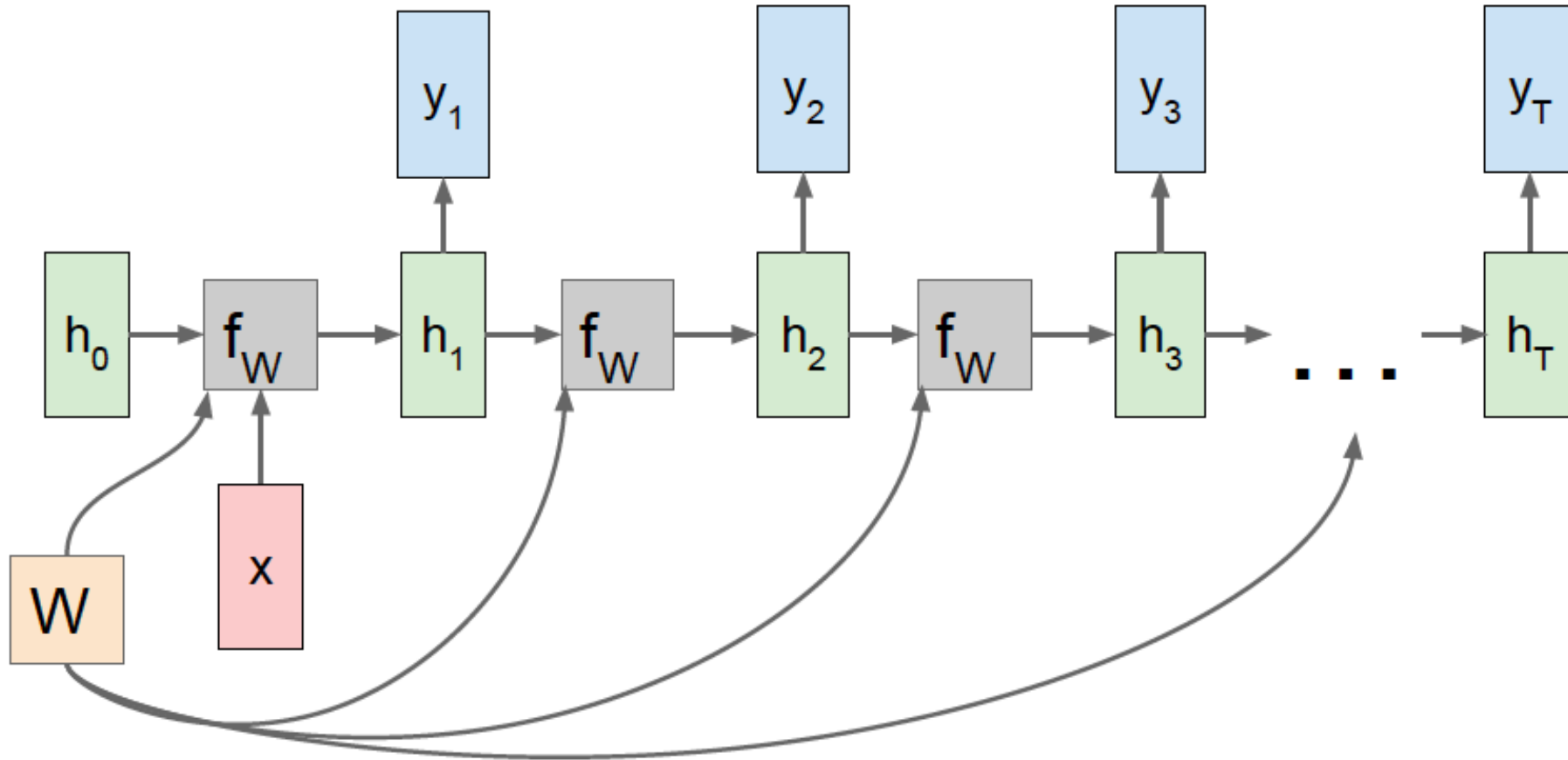

# RNN: Computational Graph: Many to One

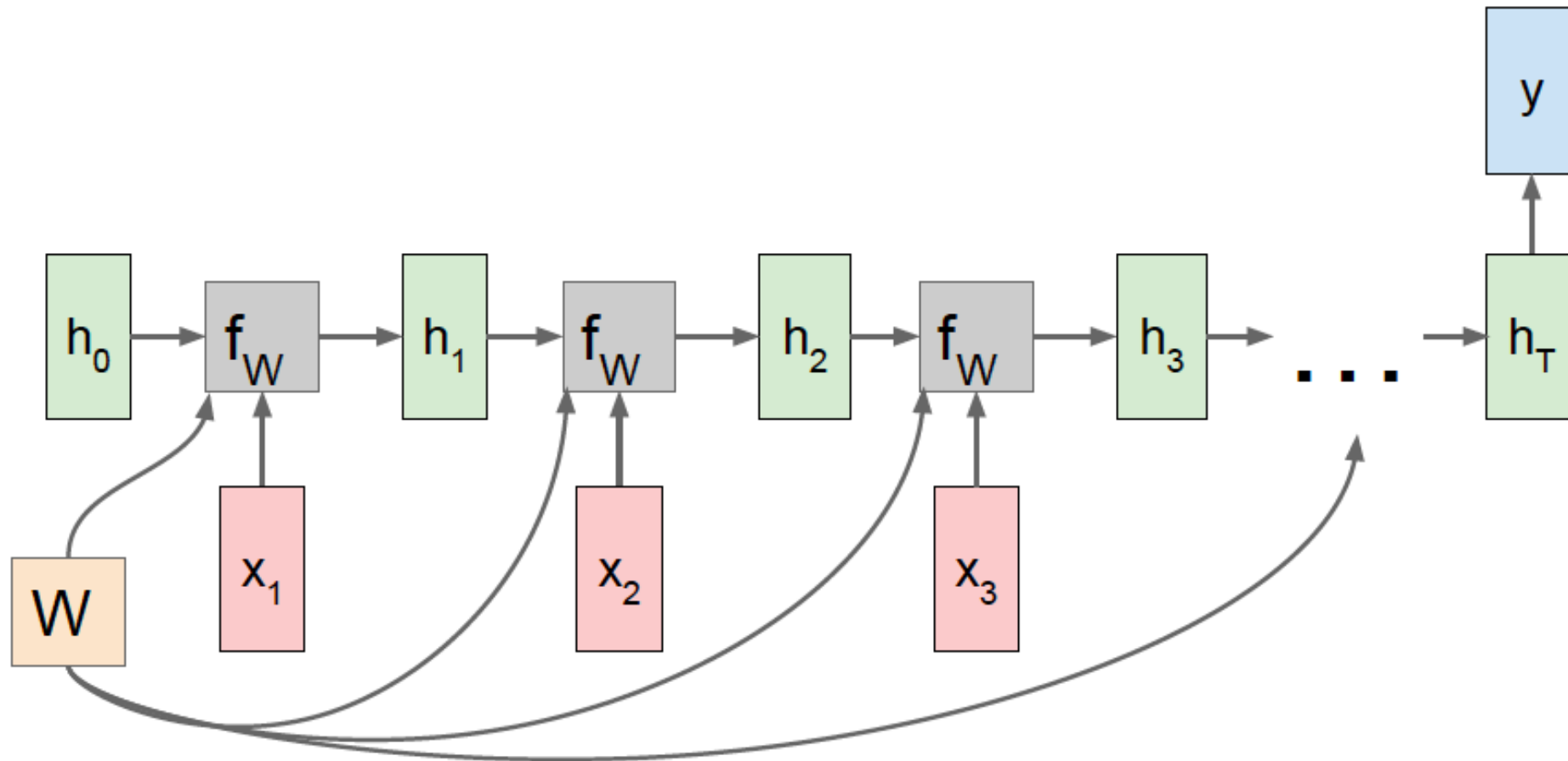

# RNN: Example Training

---

Vocabulary:  
[h,e,l,o]

Example training  
sequence:  
“hello”

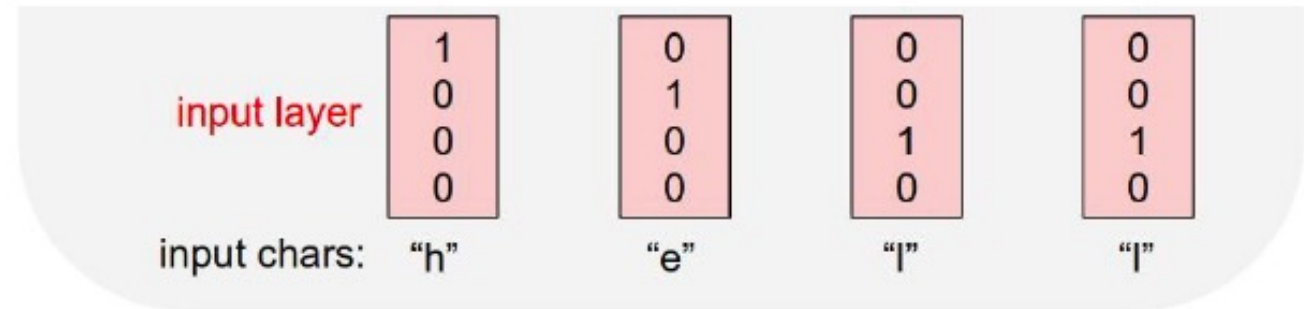



# RNN: Example Training

## Example: Character-level Language Model

Vocabulary:  
[h,e,l,o]

Example training  
sequence:  
“hello”

$$h_t = \tanh(W_{hh}h_{t-1} + W_{xh}x_t)$$

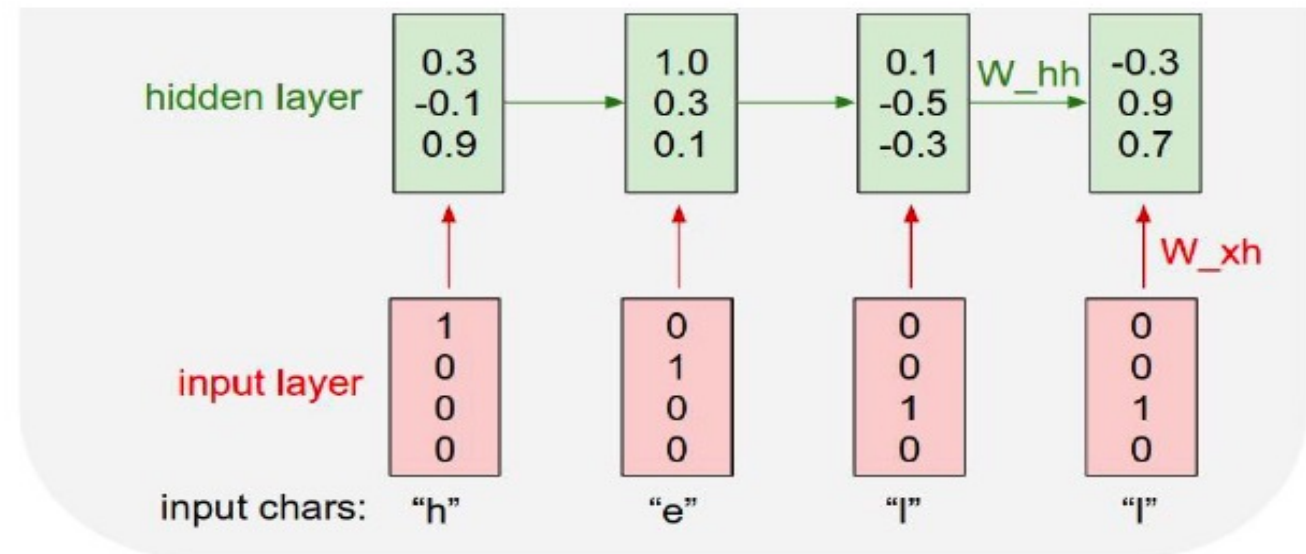

# RNN: Example Training

## Example: Character-level Language Model

Vocabulary:  
[h,e,l,o]

Example training  
sequence:  
“hello”

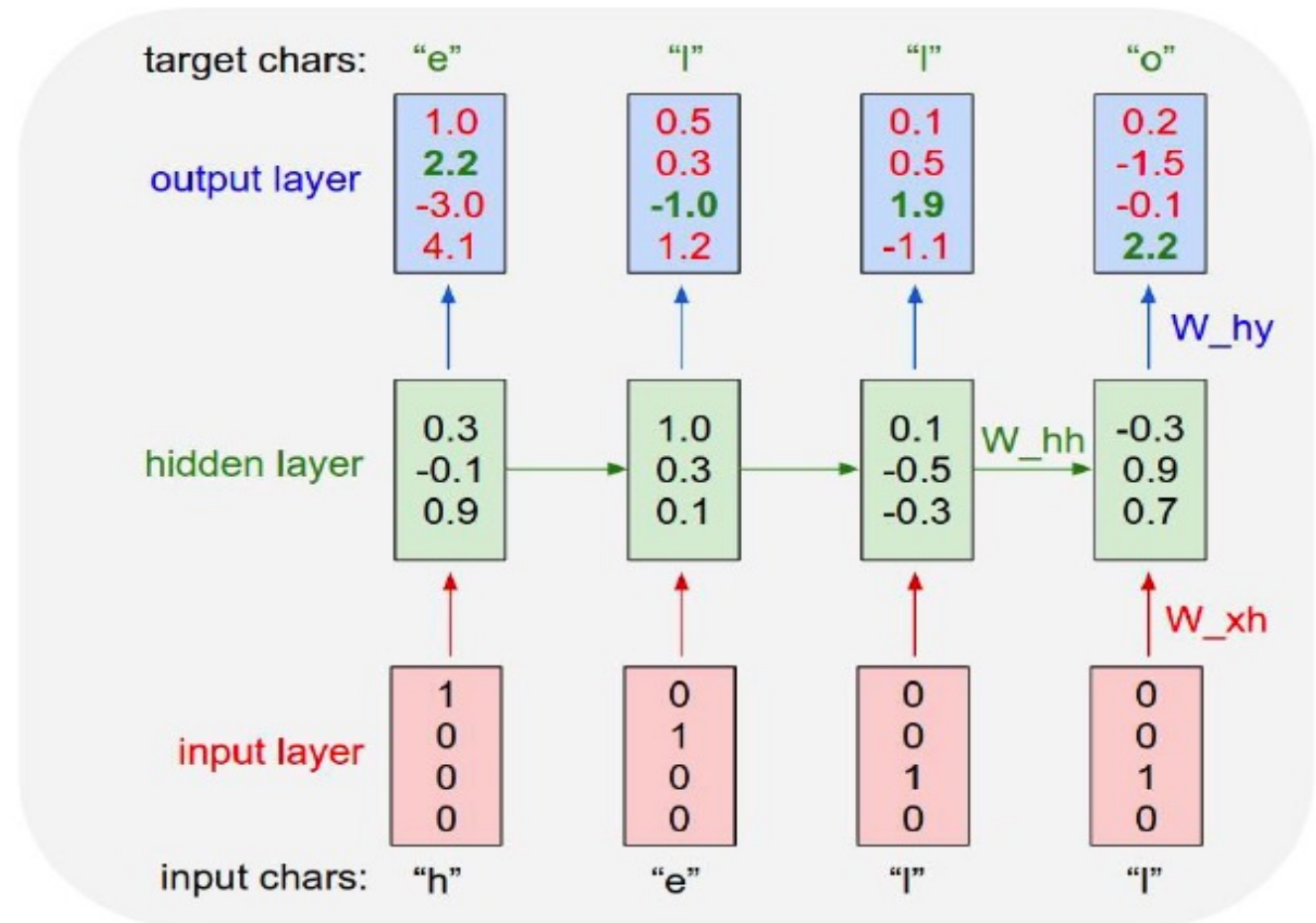

# RNN: Example Test

## Example: Character-level Language Model Sampling

Vocabulary:  
[h,e,l,o]

At test-time sample  
characters one at a time,  
feed back to model

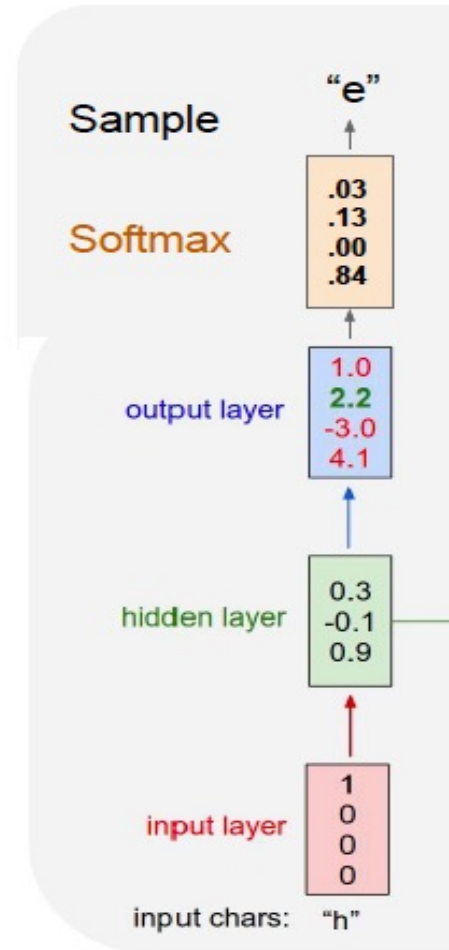

# RNN: Example Test

## Example: Character-level Language Model Sampling

Vocabulary:  
[h,e,l,o]

At test-time sample  
characters one at a time,  
feed back to model

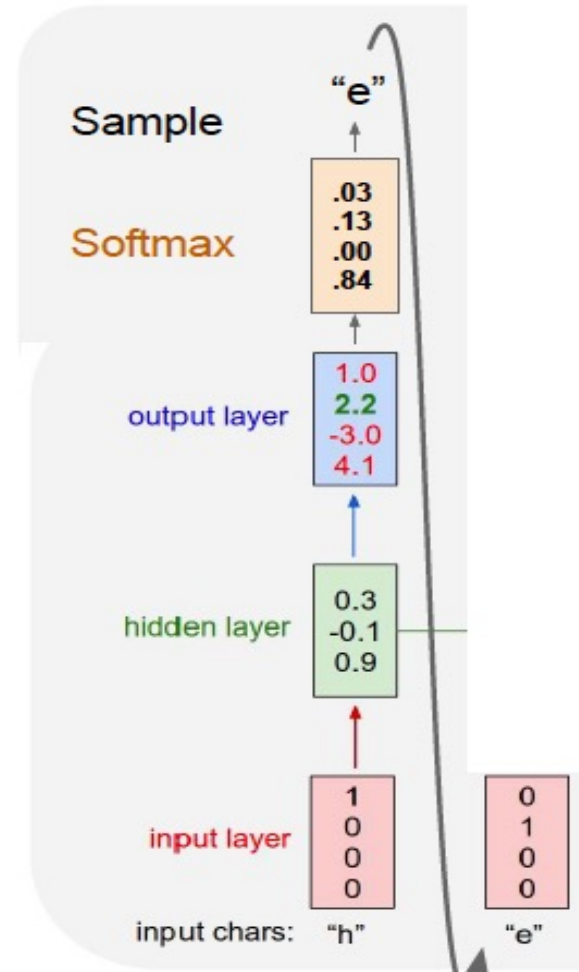

# RNN: Example Test

## Example: Character-level Language Model Sampling

Vocabulary:  
[h,e,l,o]

At test-time sample  
characters one at a time,  
feed back to model

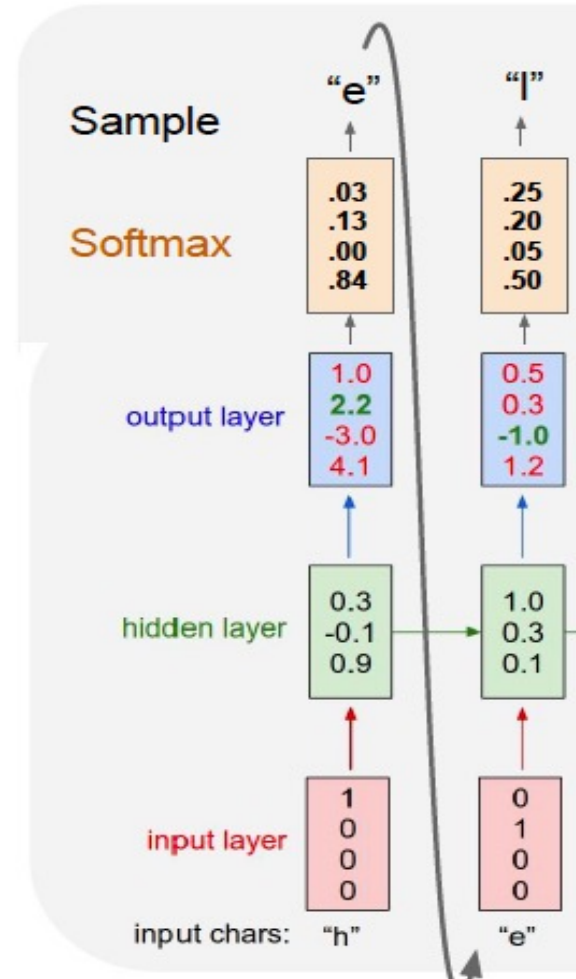

# RNN: Example Test

**Example:  
Character-level  
Language Model  
Sampling**

Vocabulary:  
[h,e,l,o]

At test-time sample  
characters one at a time,  
feed back to model

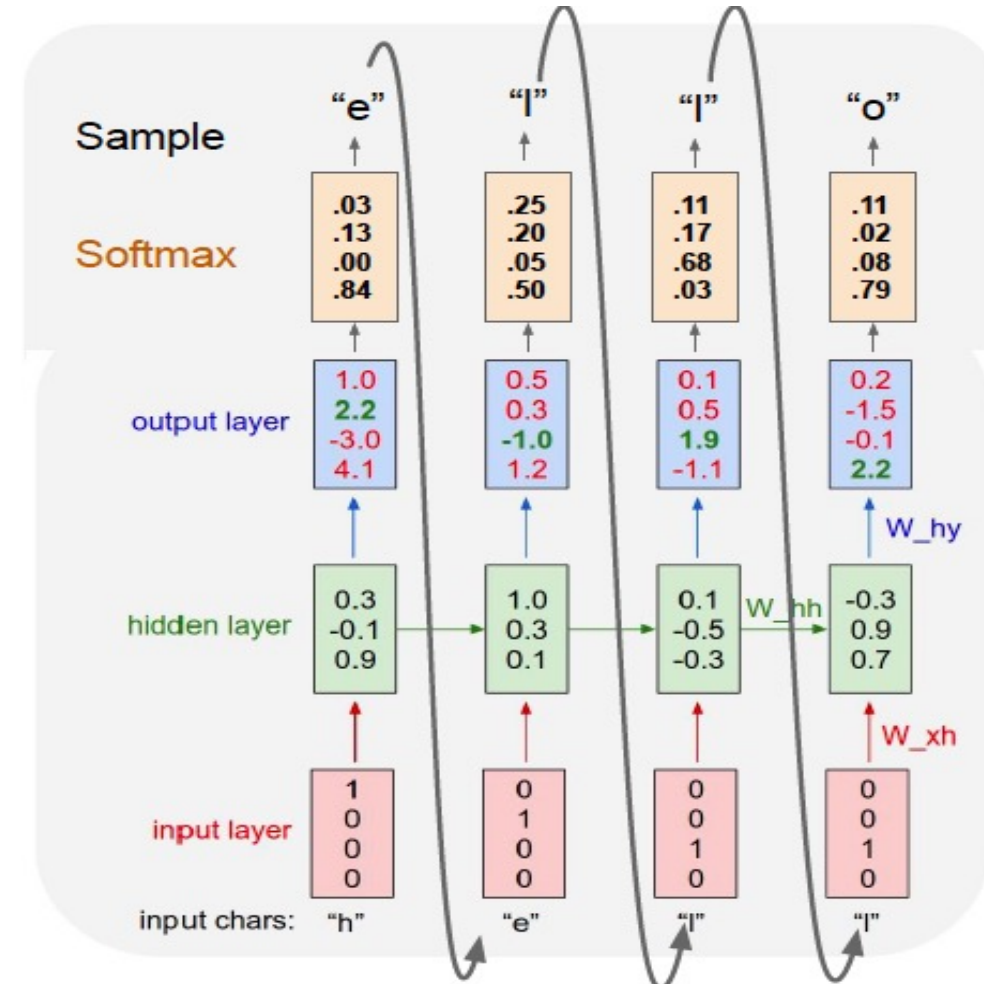

# References

- Artificial Neural Network. Chapter 5.4 and 5.5. Introduction to Data Mining.
- Hands-on Machine Learning with Scikit-Learn, Keras & Tensorflow. A practical handbook to start wrestling with Machine Learning models (2nd ed).
- Deep Learning. Ian Goodfellow, Yoshua Bengio, and Aaron Courville. The reference book for deep learning models.

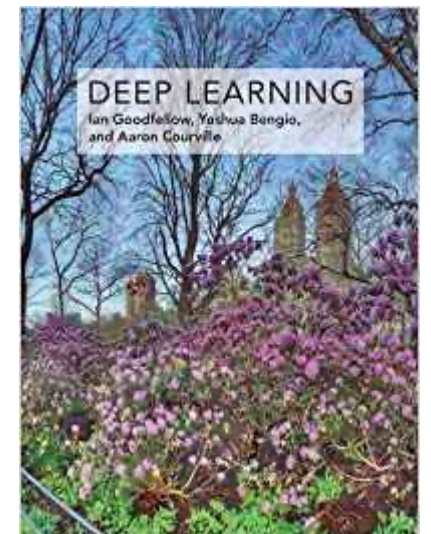
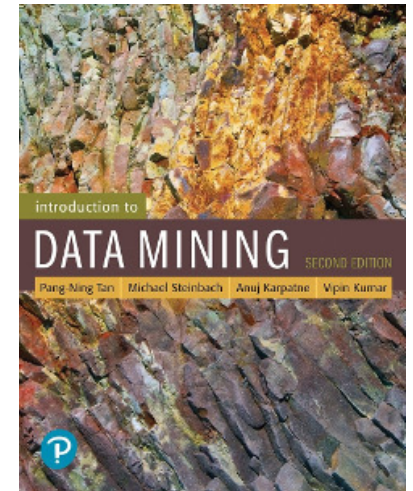
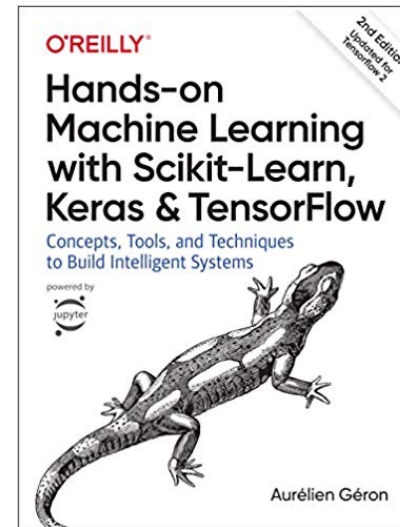

# Exercises - Neural Network

---



# Predict with a Neural Network

- Given the following NN with
  - assigned weights (see figure)
  - activation function  $f(S) = \text{sign}(S-0.2)$  for all nodes
- Label the test set on the right, then compute accuracy, and precision & recall for both classes

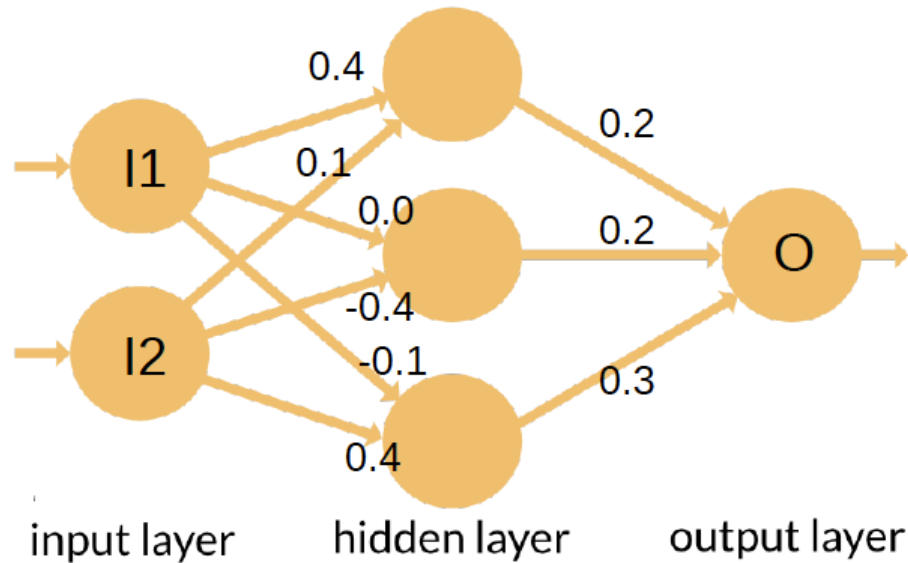

I1	I2	O
-1	+1	
+1	+1	
+1	-1	
+1	-1	
-1	+1	
+1	+1	
-1	-1	
+1	+1	
-1	-1	
+1	+1	

# Predict with a Neural Network - Solution

- Given the following NN with
  - assigned weights (see figure)
  - activation function  $f(S) = \text{sign}(S-0.2)$  for all nodes
- Label the test set on the right, then compute accuracy and precision & recall for both classes

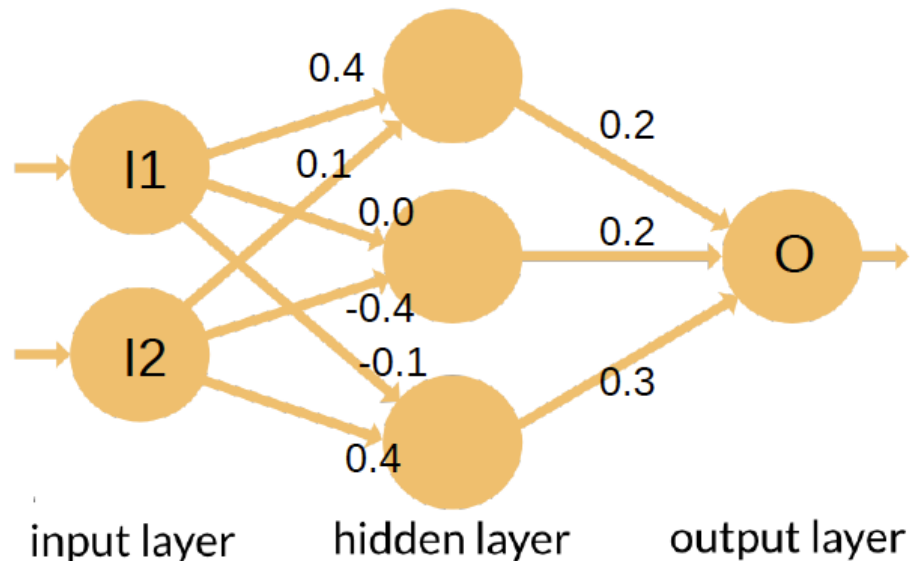

$$H_1 = \text{sign}(0.4 * -1 + 0.1 * 1 - 0.2) = \text{sign}(-0.5) = -1$$

$$H_2 = \text{sign}(0.0 * -1 + -0.4 * 1 - 0.2) = \text{sign}(-0.6) = -1$$

$$H_3 = \text{sign}(-0.1 * -1 + 0.4 * 1 - 0.2) = \text{sign}(0.3) = 1$$

$$Y_1 = \text{sign}(0.2 * -1 + 0.2 * -1 + 0.3 * 1 - 0.2) = \text{sign}(-0.3) = -1$$

I1	I2	C
-1	+1	-1
+1	+1	+1
+1	-1	-1
+1	-1	+1
-1	+1	+1
+1	+1	+1
-1	-1	-1
+1	+1	-1
-1	-1	-1
+1	+1	+1

# Predict with a Neural Network

Given the neural network below (on the left), apply it to the test set provided (on the right). The weights are reported beside each connection, while the activation function is simply  $f(S) = \text{sign}(S)$ , i.e. -1 for positive values, +1 for positive ones and 0 for  $S=0$ . For each case, show the output also of the nodes on the hidden layer.

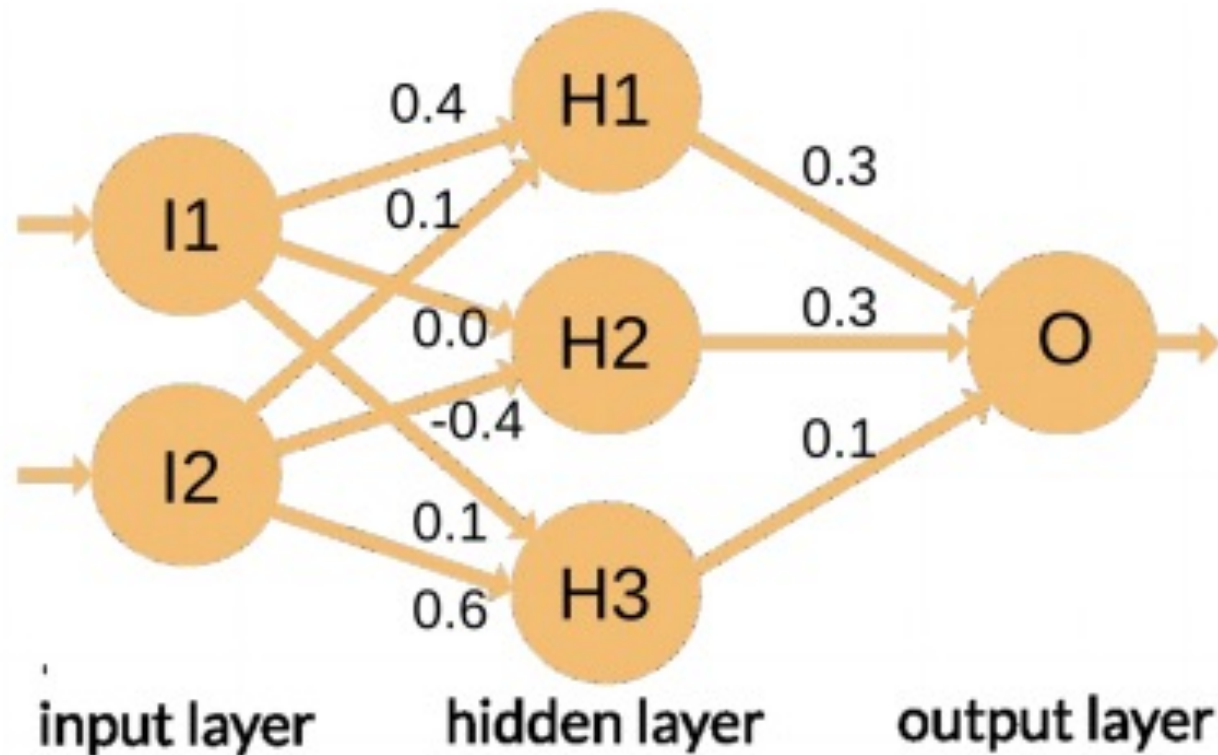

I1	I2	O
+0	-1	
+1	+0	
-1	+1	
+1	+1	
+1	-1	

# Predict with a Neural Network - Solution

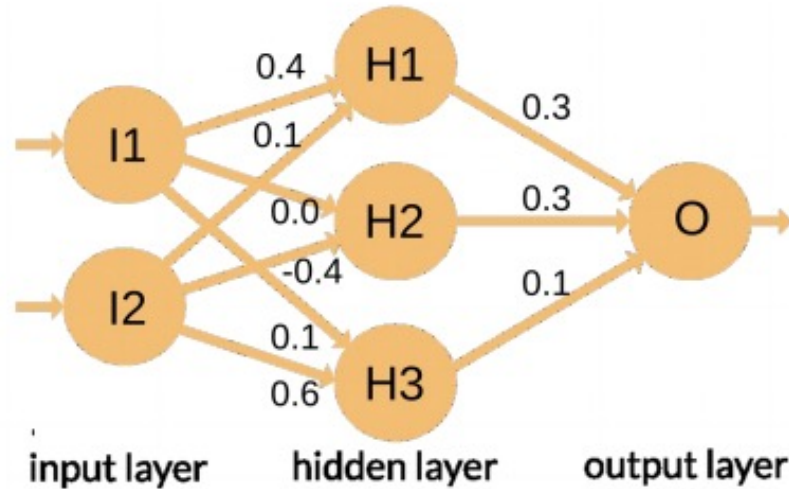

**Answer:**

	I1	I2	O
	+0	-1	-1
	+1	+0	+1
	-1	+1	-1
	+1	+1	+1
	+1	-1	+1

Input1	0	1	-1	1	1	1
Input2	-1	0	1	1	1	-1
H1	-1	1	-1	1	1	1
H2	1	0	-1	-1	-1	1
H3	-1	1	1	1	1	-1
Output	-1	1	-1	1	1	1