

# Methods for the specification and verification of business processes

MPB (6 cfu, 295AA)

Roberto Bruni

<http://www.di.unipi.it/~bruni>

02 - Business processes

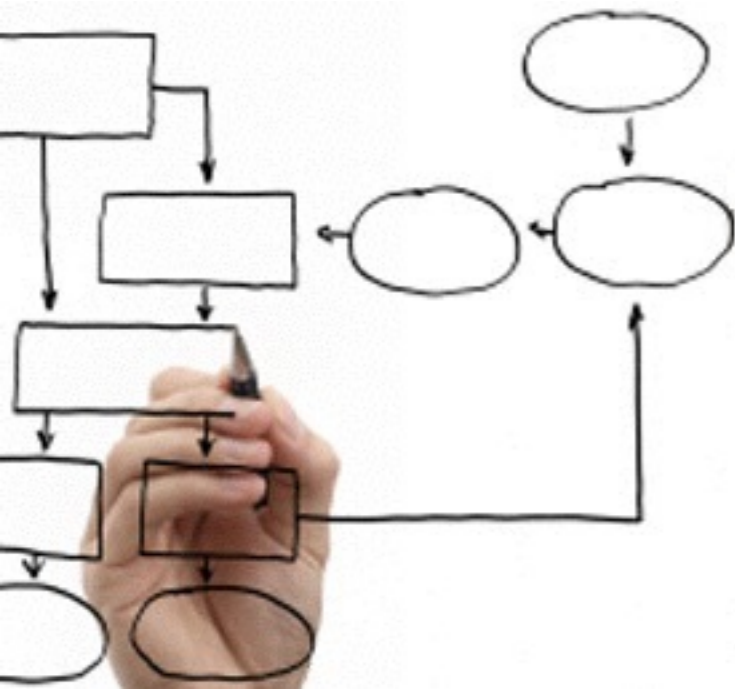

# Classes

Wednesday 14:00-16:00 Room N1

Friday 11:00-13:00 Room L1

Today:

*Ch.1 of Workflow Management: Models, Methods, and Systems*

*Ch.1 of Business Process Management: Concepts, Languages, Architectures*

# Digression...

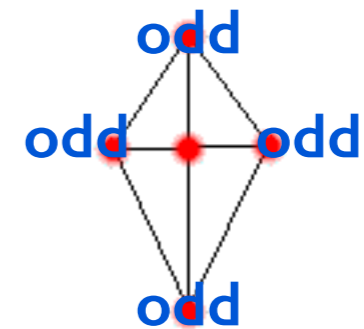
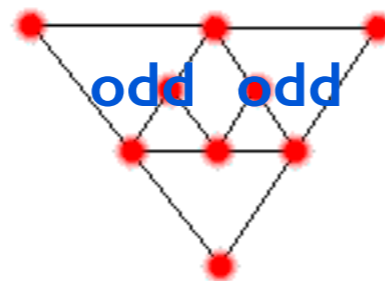
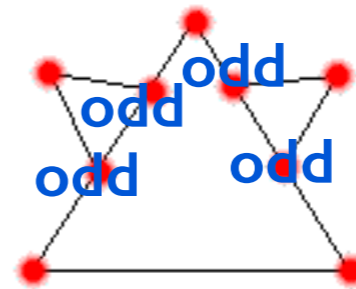
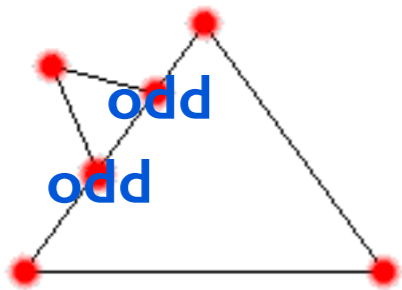

**Exercises:** find Eulerian circuits in the graphs above or prove that they cannot exist.

# Digression...

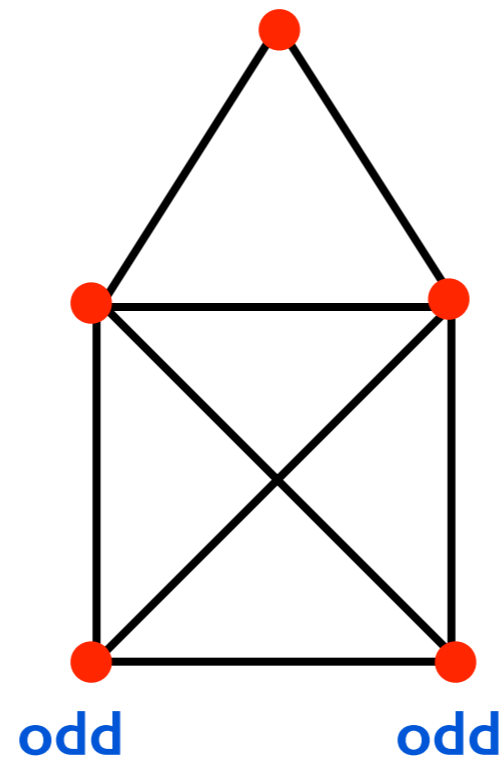

**An childish puzzle**

# Reference framework

Fix the business management context

Model and analyze processes

Functionality of processes management systems

# Terminology

Generic terms, widely applicable to different working situations and companies

We fix preferred terms when possible, but allow one to use synonyms interchangeably

# Issues

Role of work in the society

Processes and distribution of work

Principal-contractor relationship

Organizational structures

Process management

# Work

People work to live  
(or live to work?)

We need products to maintain our lives  
(food, clothing, house, transportation, fun, health)

We are not capable to produce all we need  
(or all we want, or all we are induced to want)  
because we cannot be skilled enough

We buy products we cannot make ourselves



# Business units

People organize specialized business units  
(limited range of products, highly efficient)

# Market

Products are supplied to people via markets  
(distribution in exchange of money)

# New services

Other work emerge, that would not exist  
(trading, banks, advertising, transportation,  
regulations, insurance companies)

There are services and products necessary to  
keep the organization operating  
(not making a direct contribution to keep us alive)

# Complexity

Modern society is too complex for people to see  
how their work fits in the overall scheme  
(alienation can become a major social problem)

The same scheme applies to large companies:  
high degree of work specialization  
cause big picture be lost by employees  
(why they have to do the things they are told to do)

# Paradigm shift

Alienation from work can have negative effects on  
(human life and) productivity

Companies can allow employees to know they are working  
for a particular customer  
(increase motivation, self-esteem, productivity)

## **Shift:**

from supply-driven economy (scarce means of production)  
to **demand-driven** economy (customers are scarce)

# Organizational paradigm shift

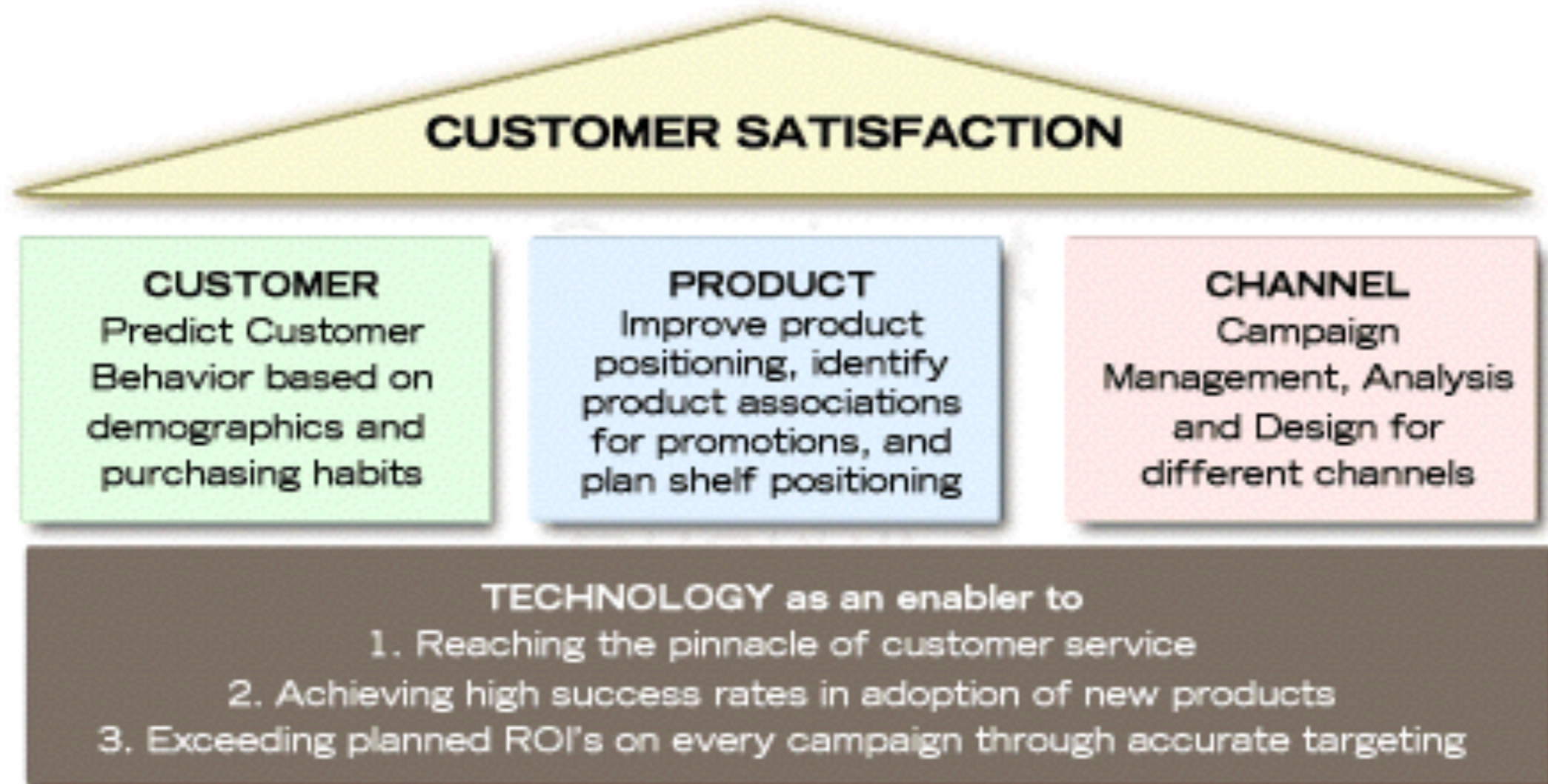

**ROI = Return On Investment**

# Issues

Role of work in the society

Processes and distribution of work

Principal-contractor relationship

Organizational structures

Process management

# Case

Many different types of work exist  
(baking bread, making furniture, design a building,  
collect surveys to compile a statistic)

They have in common the **case**:  
one tangible thing produced or modified  
(bread, furniture, house, diagram)  
more abstract cases are also possible  
(a lawsuit, an insurance claim, digital data)

**Synonyms:** work, job, product, service, item



# Procedure

Working on a case is typically discrete in nature

Every case has a beginning and an end

Each case can be distinguished from any other case

Each case involves a **procedure** being performed:  
the tasks to be carried out and the conditions that  
determine the order of the tasks

**Synonyms:** process, project

# Task

A **task** is a logical unit of work that is carried out as a single whole

# Example: Make a Pizza

1. Check ingredients
2. Check tools
3. Make the dough balls
4. Prepare toppings (while dough rises)
5. Shape dough balls into pizza
6. Top it
7. Cook it

Tasks? Procedures? Cases?

# Knowledge

Some tasks can be performed by a computer without human intervention

Executing some tasks may require human intelligence: a judgement or a decision  
(a bank employee decides about a loan request)

Persons need **knowledge** to execute tasks  
(their past experience, company guidelines)

# Resource

A **resource** is the generic name for a person, machine or group of persons or machines that is responsible for a task

# Activity

An **activity** is the performance of a task by a resource

Various cases may share the same procedure, but each case may involve different activities to be carried out, depending on case **attributes** (one insurance claim may involve objections and another one may not)

# Example: Make a Pizza

1. Check ingredients
2. Check tools
3. Make the dough balls
4. Prepare toppings (while dough rises)
5. Shape dough balls into pizza
6. Top it
7. Cook it

Knowledge? Resources? Activities?

# Example: Make a Pizza

Knowing the procedure is essential, but

Not all recipees are the same

Not all pizzas taste the same

Execution is important

Training is important



# Cases vs procedures

The number of procedures in a company is (generally) finite and far smaller than the number of cases to be handled

**Example:** it is easier to make one hundred skirts with the same pattern than one hundred skirts using different patterns

**Example:** off-the-rack is cheaper than made-to-measure

# Economy of scale

The cost per case fall as the number of cases increases

**Strategy:** keep the number of procedures small and make the number of cases that each can perform as high as possible

Profit, after all, is the ultimate objective  
(not necessarily the best one)

# Example

Insurance companies want to keep the number of claims as low as possible, but this is generally a factor they cannot control

They can try to keep low the number of procedures, but the risk is to make them too much complex (a unique procedure to handle all cases is possible in principle, but inefficient in practice)

**Ideal situation:** a small number of good procedures, with a lot of cases to be handled by each of them

# Different examples

What about tailor-made suits?  
one case per process?

What about architects and houses?  
design from scratch for each case?

# Not so different?

Tailors and architects can exploit standard approaches for each case

Tailor process:  
take customer's measurement,  
show a number of patterns,  
modify the chosen pattern,  
choose the fabric,  
draw the pattern

**Observation:** tasks can be highly dependent on cases

# One-of-a-kind processes

The first stage in tackling the case is the design of its specific process

Even in this case, standard tasks can be frequently found that are used to compile many specific processes

# Issues

Role of work in the society

Processes and distribution of work

Principal-contractor relationship

Organizational structures

Process management

# Principal

Most people's work is assigned or outsourced to them by other people: their **principals** (they can be company departments or firms)

We can divide principals in two forms:  
**boss** and **customer**

Assignments ordered by bosses are related to work for customers  
(directly in case of production process, indirectly for support and managerial processes)



# Contractors

A person who is assigned a task is called **contractor**, or also **resource**  
(assignments can be carried out by machines and computer applications as well as by people)

# Actors

An **actor** can be a principal or a contractor, or  
play both roles at the same time  
(contractors may redirect work to third parties)

# Contract

A **contract** exists between a principal and a contractor about the case to be performed (deadline for completion, price to be paid)

A **communication** protocol can be established between a principal and a contractor to exchange information

# Protocol example

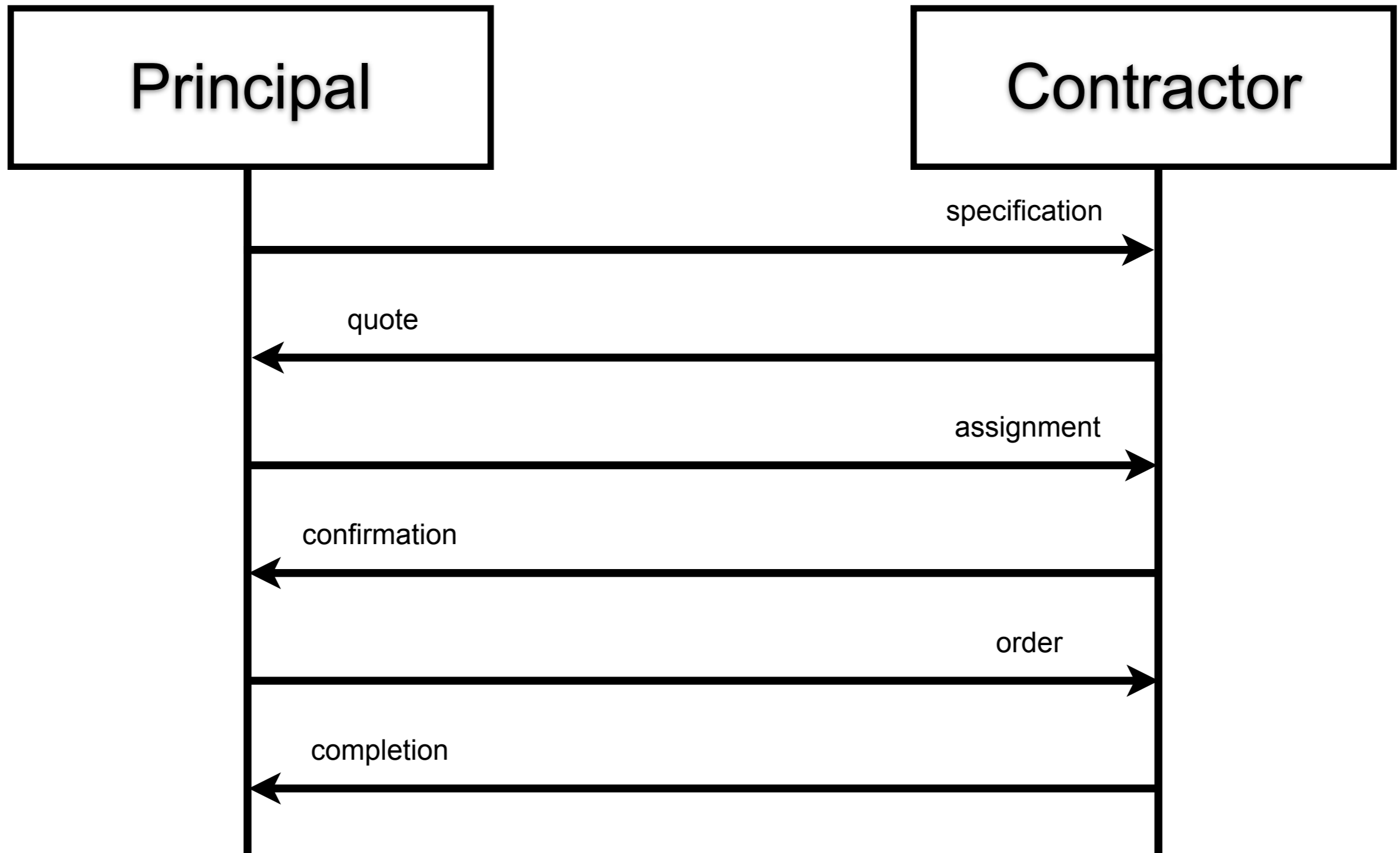

# Contract tree example

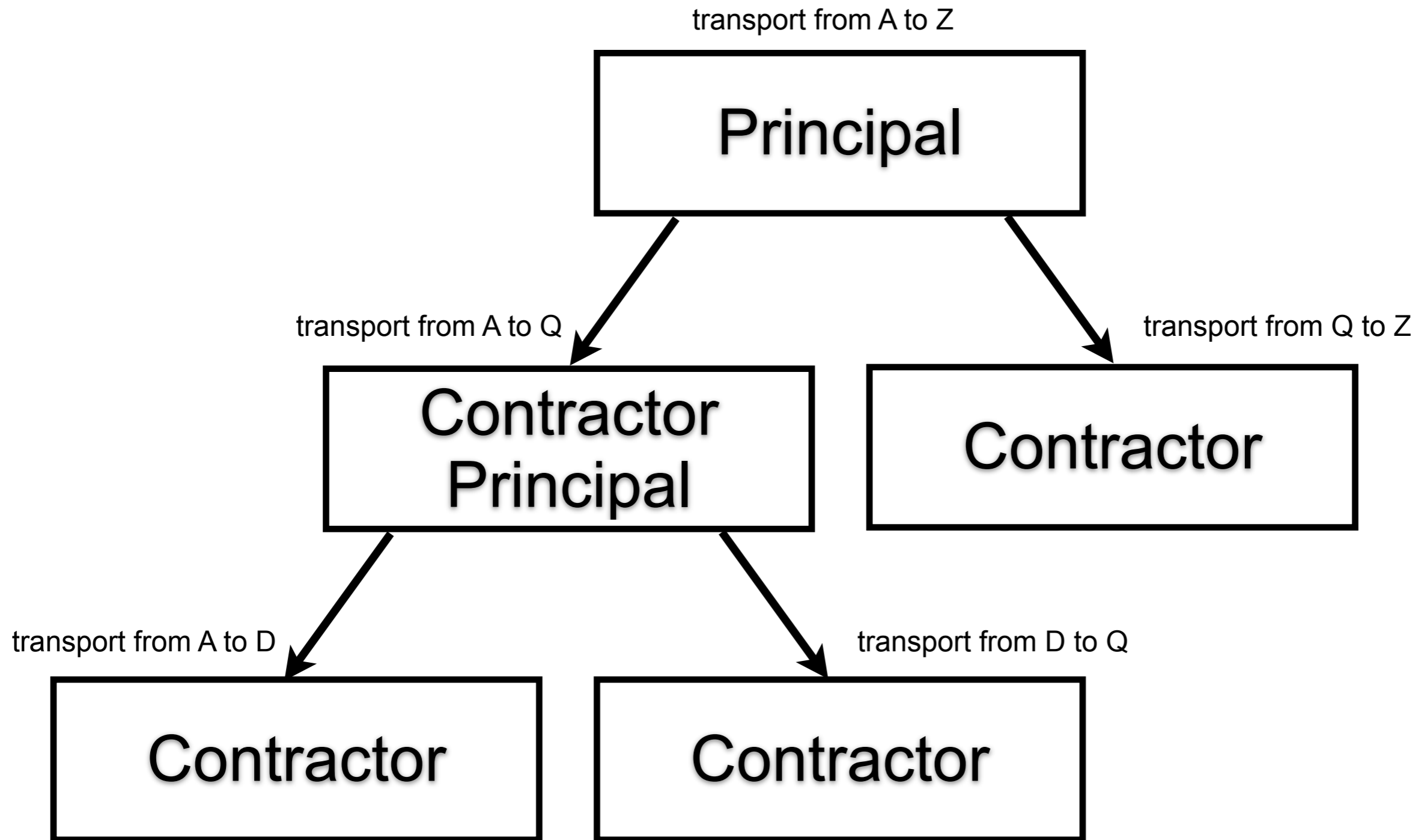

# Issues

Role of work in the society

Processes and distribution of work

Principal-contractor relationship

Organizational structures

Process management



# Organizational structure

An **organizational structure** establishes how the work, authorities and responsibilities are divided up amongst its staff  
(roles and functions)

A single person can fulfill several roles, together or along time



# Most relevant forms of organizational structure

**Hierarchical:** structured as a tree, internal nodes are individual roles or functions, leaves are staff or departments, branches are authority relationships (independent of cases)

**Matrix:** add (dynamic) functional dimension (each person can have one or more functional bosses, known as project leaders)

**Network:** autonomous actors collaborate to supply products or services

# Hierarchical organizational structure

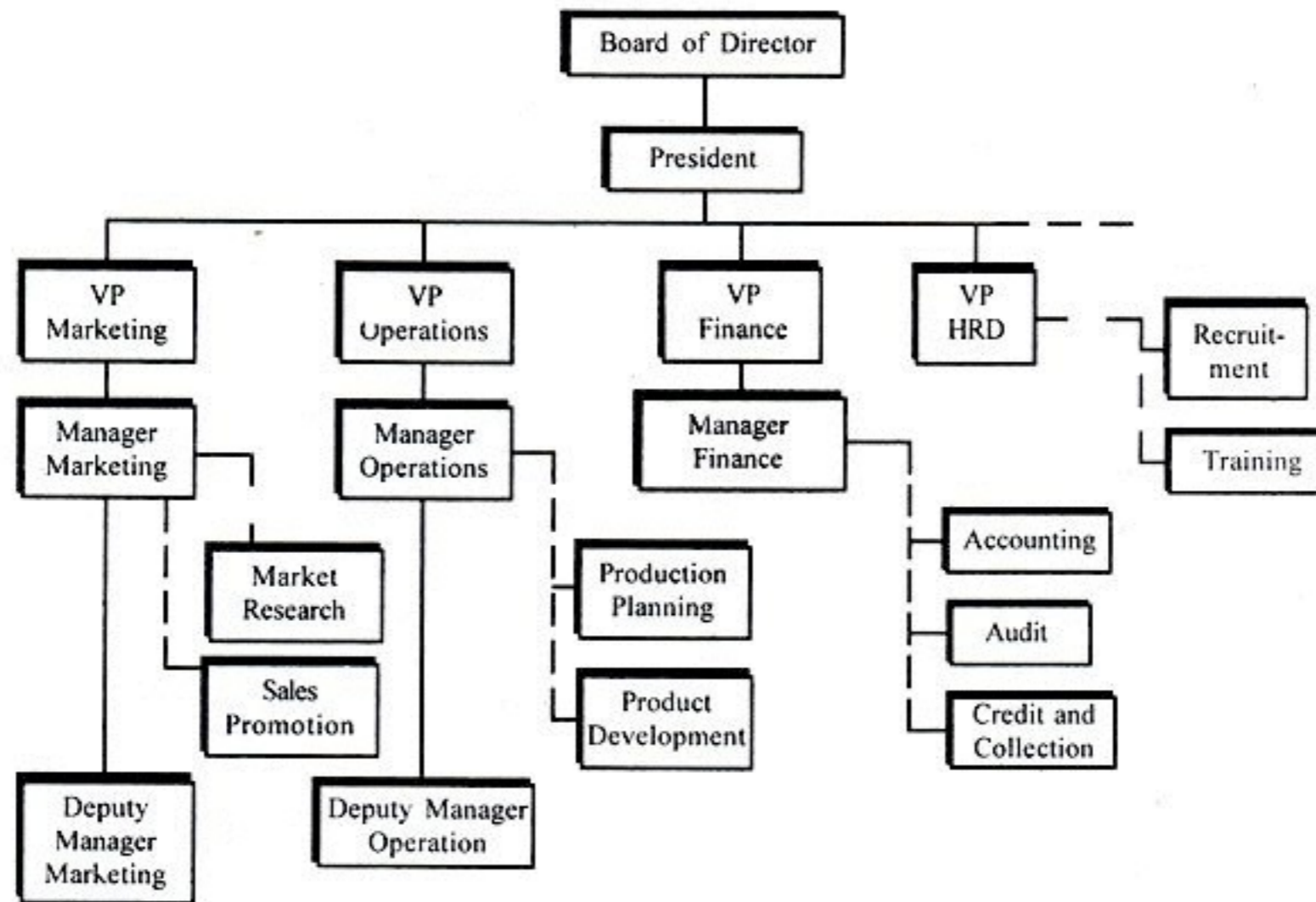

Legend : — Line Authority  
 -- Staff Relationship

# Matrix organizational structure

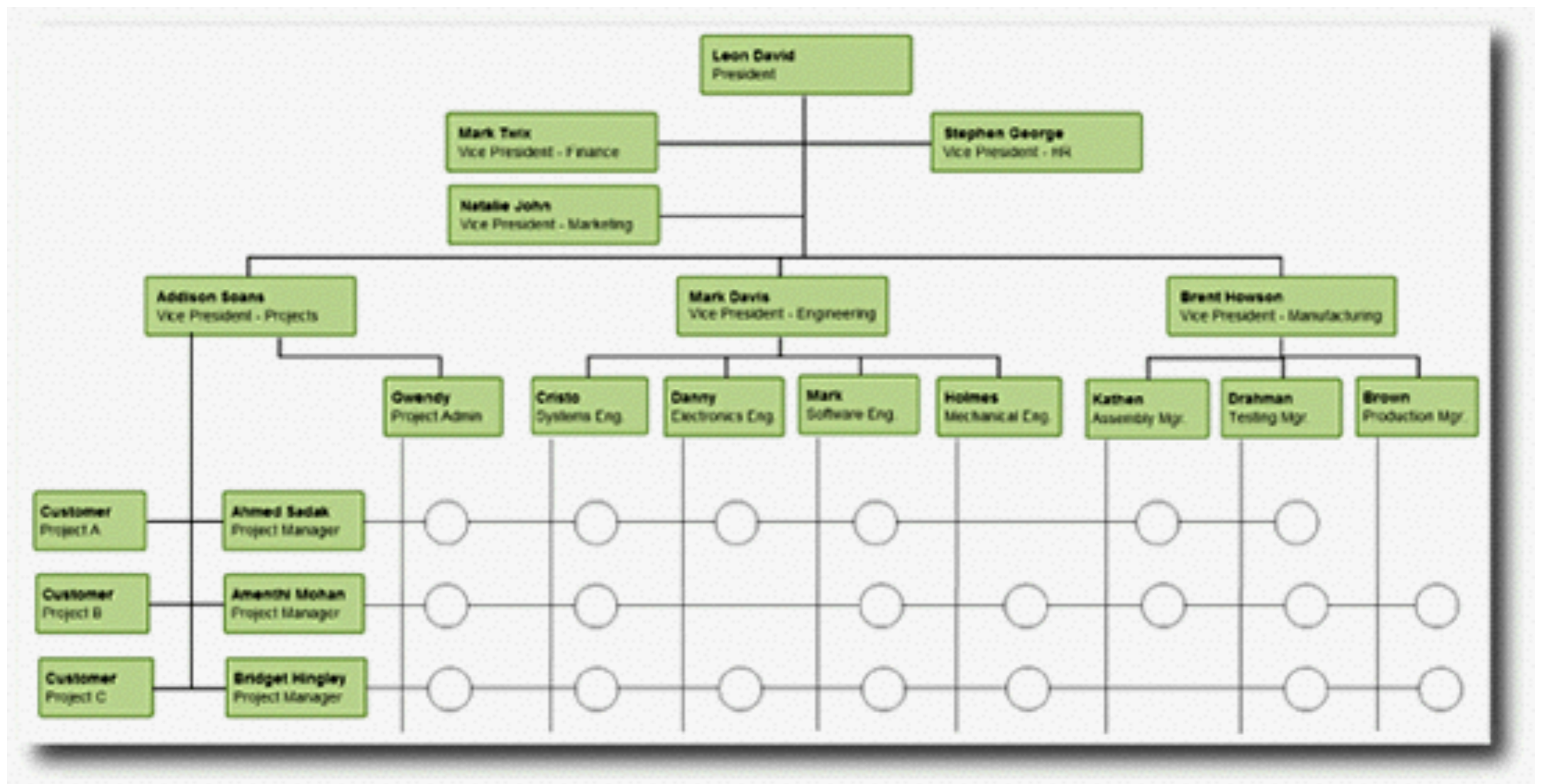

# Network organizational structure

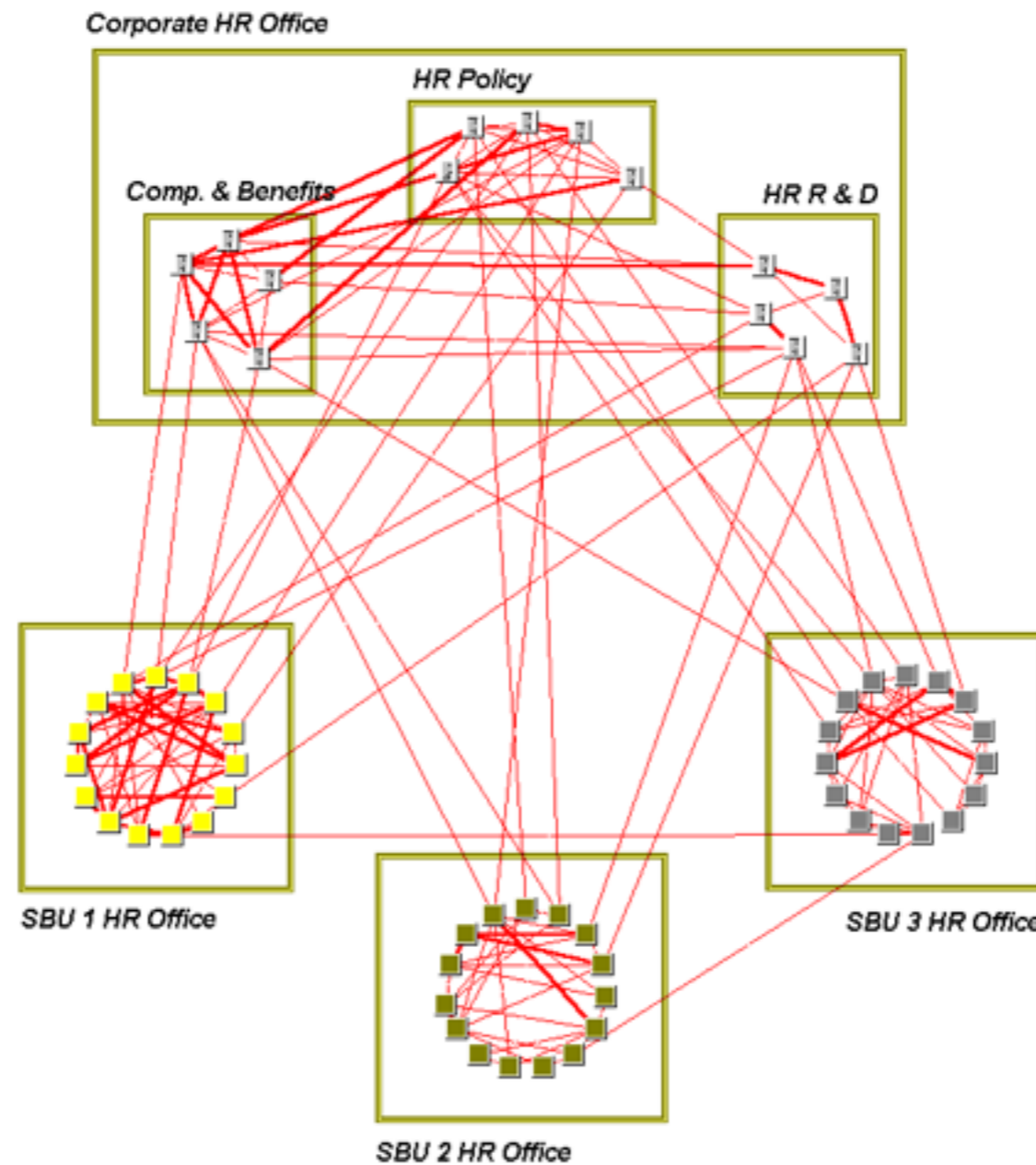

# Issues

Role of work in the society

Processes and distribution of work

Principal-contractor relationship

Organizational structures

Process management

# What is all about

Each **product** that a company provides to the market is the outcome of a number of **activities** performed



Business processes are about activities **understanding, correlation, organization and improvement**

# Awareness

Process management systems  
**support and encourage**  
communication between employees  
and make their activities more controllable

# Narrowing the gap

Organizational business aspects



Information technology



# Enactment

Activities can be performed by employees **manually** or by the help of information systems

Other activities can be enacted **automatically** by information systems

Some activities can **trigger** or **inhibit** other activities

# Process orientation roots (1990's)

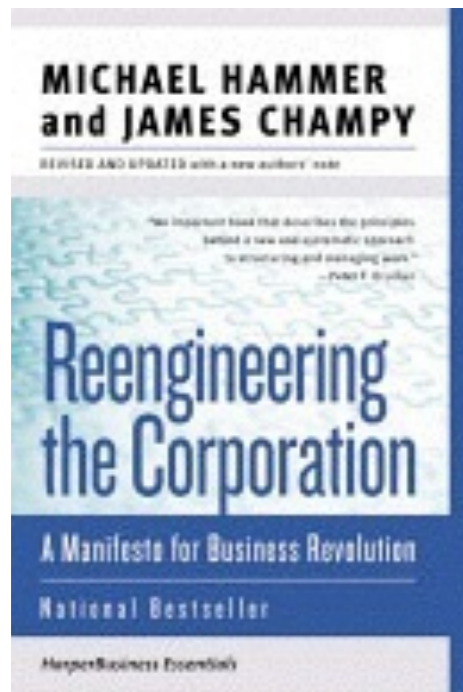

Seminal book advocating the radical redesign of the business process of a company as opposed to evolutionary improvements

A **business process** is a **collection of activities** that take one or more kinds of **input** and create an **output** that is of value to the customer

*- Hammer & Champy (1993)*

# Keywords

*Hammer & Champy:* **collection, input, output**

# How vs What

The main innovation is the shift of focus on the business logic of the process (**how work is done**), instead of the product perspective (**what is done**)

# Process orientation roots (1990's)

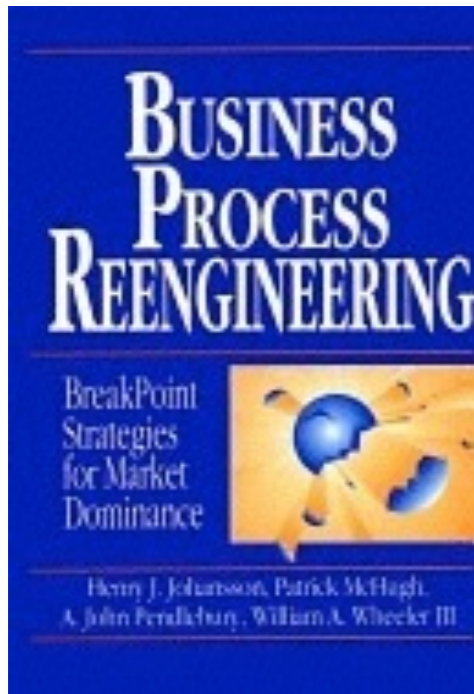

The transformation that occurs in the process should add value to the input and create an output that is more useful and effective to the recipient either **upstream** or **downstream**

A process is a set of **linked** activities that take an input and transform it to create an output.

- *Johansson et al. (1993)*

# Keywords

*Hammer & Champy:* **collection, input, output**

*Johansson et al.:* **upstream, downstream, linked**

# Process orientation roots (1990's)

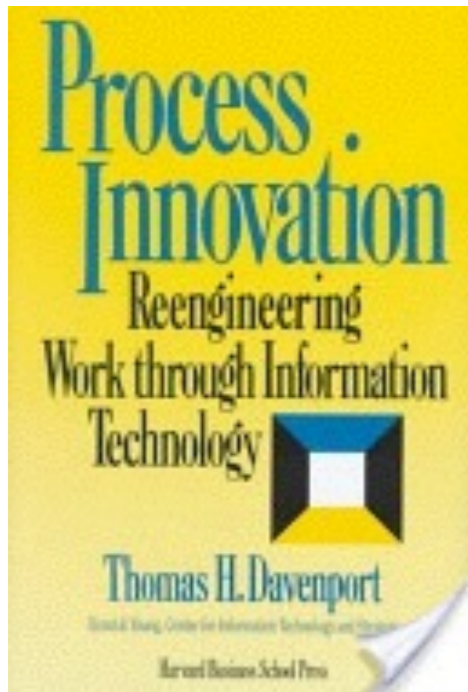

Processes as structured, measured sets of activities designed to produce a specific output for a particular market

A **process** is a specific **ordering** of work activities across **time** and **space**, with a **beginning** and an **end**, and clearly defined **inputs** and **outputs**: a structure for action.

*- Davenport (1993)*

# Keywords

*Hammer & Champy:* **collection, input, output**

*Johansson et al.:* **upstream, downstream, linked**

*Davenport:* **structure, ordering, time, space, begin, end**



# More from Davenport

Unless designers or participants can agree on the way work is and should be **structured**, it will be very difficult to systematically improve, or effect innovation in, that work

Whereas an organization's hierarchical structure is typically a slice-in-time view of responsibilities and reporting relationships, its process structure is a **dynamic view** of how the organization delivers value

# More from Davenport

Furthermore, while we cannot measure or improve hierarchical structure in any absolute sense, processes that are clearly structured are amenable to **measurement** in a variety of dimensions have cost, time, output quality, and customer satisfaction

When we reduce cost or increase customer satisfaction, we have bettered the process itself

# More from Davenport

Processes also need clearly defined **owners** to be responsible for design and execution.

Process ownership must be seen as an additional or alternative dimension of the formal organizational structure that, during periods of radical process change, **takes precedence** over other dimensions of structure.

Otherwise process owners will not have the power or legitimacy needed to implement process designs that violate organizational charts and norms

# More from Davenport

In service industries it is nearly impossible to distinguish between innovative new services offered to the customers and the **innovative processes** that enable them

Following a structured process is generally a good thing, and there is nothing inherently slow or inefficient about acting along process lines

# Keywords

*Hammer & Champy:* **collection, input, output**

*Johansson et al.:* **upstream, downstream, linked**

*Davenport:* **structure, ordering, time, space, begin, end, dynamic, measurement, owner, precedence of process view, innovation enabling**

# Process orientation roots (1990's)

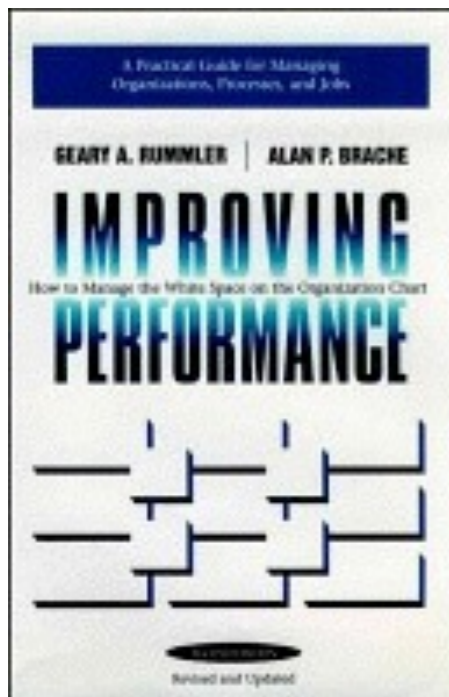

Most processes are **cross-functional**, spanning the 'white space' between the boxes on the organization chart. Some processes result in a product or service that is received by an organization's external customer. We call these **production** processes.

Other processes produce products that are invisible to the external customer but essential to the effective management of the business.

We call these **support** processes

# General applicability

The approach can be applied to both large and small processes: to the entire set of activities that serves customers, or only to answering a letter of complaint.

The larger the process, however, the greater the potential for radical benefit

Key generic business processes include product development, customer order fulfillment, and financial asset management

# Typical processes in manufacturing firms

**Operational:** product development, customer acquisition, customer requirements identification, manufacturing, integrated logistics, order management, post-sales service

**Management:** performance monitoring, information management, asset management, human resource management, planning and resource allocation



# Primary process

Produce company's products  
(**production** processes)

Customer-oriented, even if sometimes the customer is not known in advance

Generate income for the company

**Examples:** raw materials purchase, service sale, design and engineering, distribution

# Secondary process

Support primary processes  
(**support** processes)

**Examples:** machinery purchase and maintenance, personnel management (recruitment and selection, training, work appraisal, payrolls, dismissal), financial administration, marketing

# Tertiary process

Direct and coordinate primary and secondary ones  
(**managerial** processes)

Fix objectives, allocated resources and  
preconditions for the managers of other processes

**Examples:** maintenance of contracts with  
financiers and other stakeholders

# 1, 2, 3

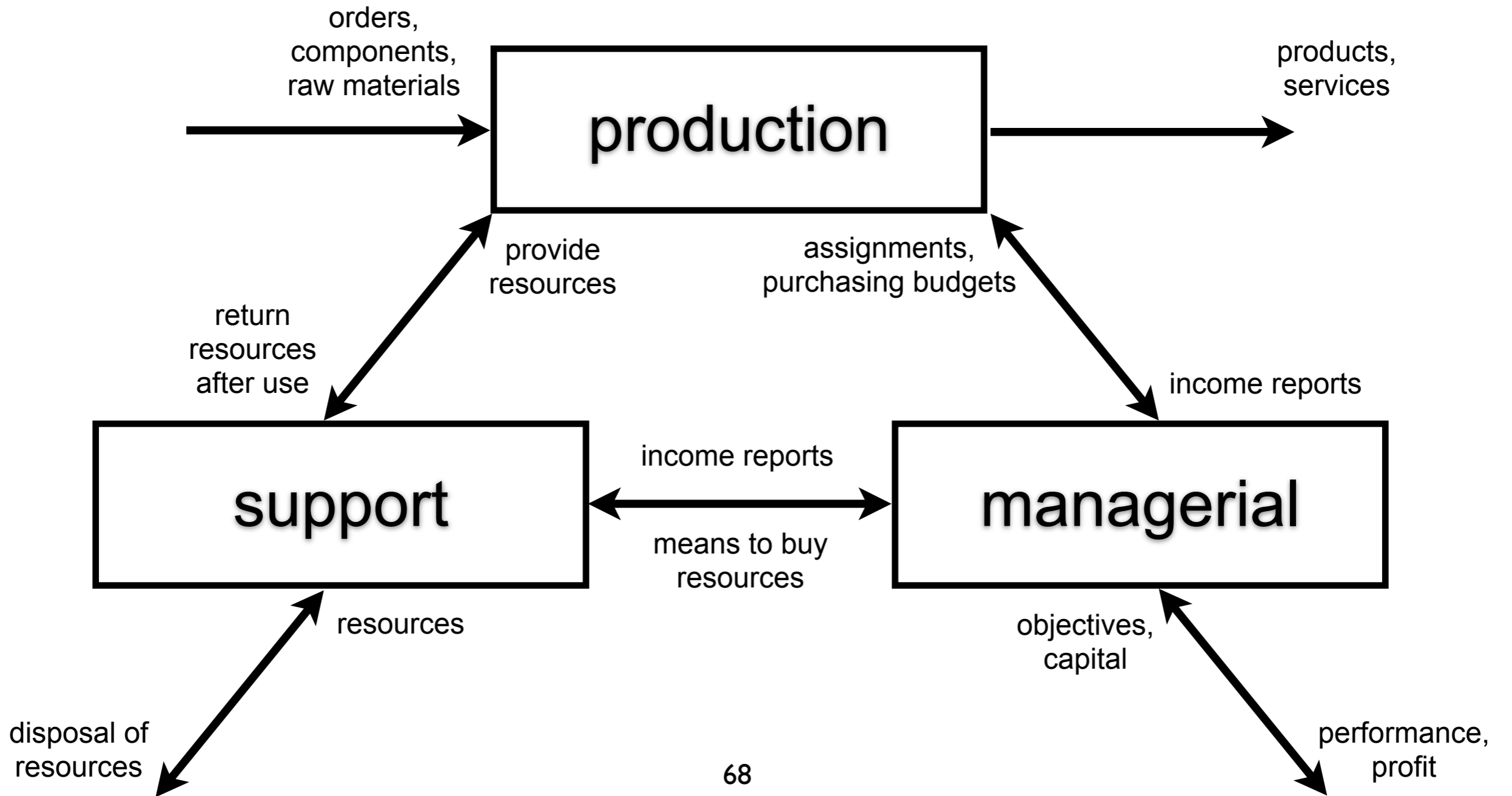

# Keywords

*Hammer & Champy:* **collection, input, output**

*Johansson et al.:* **upstream, downstream, linked**

*Davenport:* **structure, ordering, time, space, begin, end, dynamic, measurement, owner, precedence of process view, innovation enabling**

*Rummler & Brache:* **production, support, managerial**

Summing up

# Definability

Processes must have clearly defined boundaries, input and output



# Structured

Processes wrap up a collection of tasks

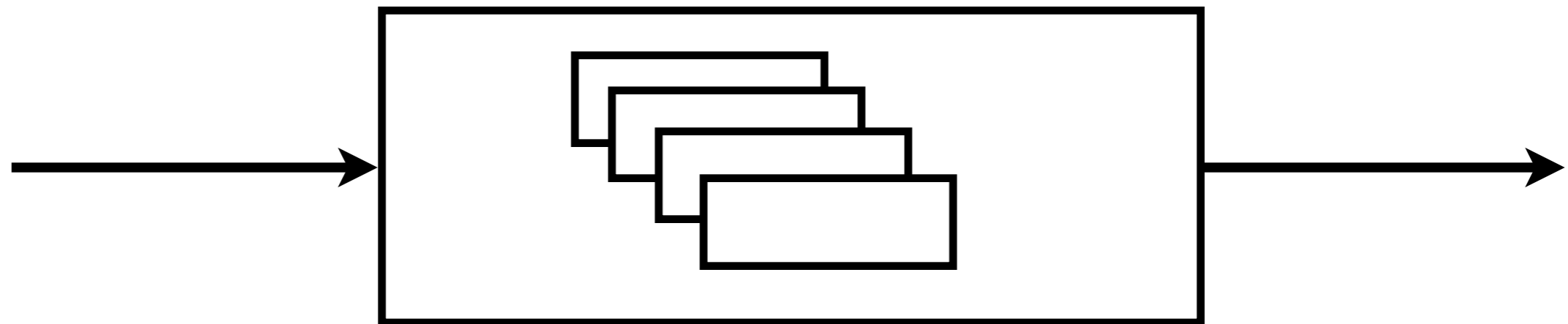



# Ordered

Process tasks are ordered according to their position in time and space

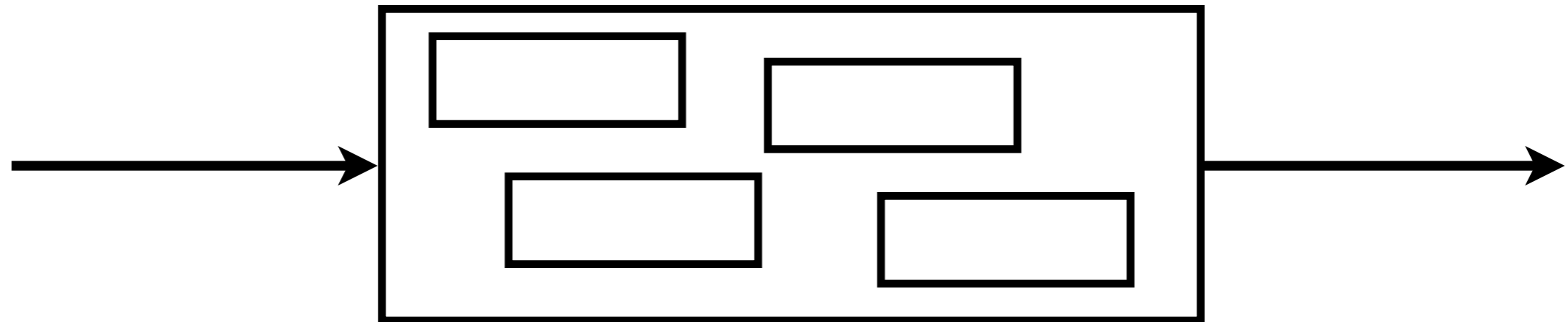

# Digression

What is a **partial order**?

- $(S, \sqsubseteq)$   $S$  is a set
- $\sqsubseteq$  is a binary relation included in  $S \times S$
- $\sqsubseteq$  is reflexive
- $\forall x \in S$  we have  $x \sqsubseteq x$
- $\sqsubseteq$  is transitive
- $\forall x, y, z \in S$ , if  $x \sqsubseteq y$  and  $y \sqsubseteq z$ , then  $x \sqsubseteq z$
- $\sqsubseteq$  is anti-symmetric
- $\forall x, y \in S$ , if  $x \sqsubseteq y$  and  $y \sqsubseteq x$ , then  $x = y$

# Digression

What is a **total order**?

$(S, \sqsubseteq)$  is a partial order and

$\forall x, y \in S$  we have  $x \sqsubseteq y$  or  $y \sqsubseteq x$

# Exercises

Are the following pairs partial / total orders?

$(\mathbf{Nat}, <)$        $(\mathbf{Nat}, \leq)$        $(\mathbf{Int}, \geq)$

$(\mathbf{Nat}, \emptyset)$        $(\mathbf{Nat}, \mathbf{Nat} \times \mathbf{Nat})$

$(\wp(\mathbf{Nat}), \subseteq)$        $(\mathbf{Nat}, \{(x, x) \mid x \in \mathbf{Nat}\})$

# Digression

What is a **linear extension** of a partial order?

Let  $(S, \sqsubseteq)$  be a partial order and  $(S, \preceq)$  a total order

$(S, \preceq)$  is a linear extension of  $(S, \sqsubseteq)$  if

$\forall x, y \in S$  we have that  $x \sqsubseteq y$  implies  $x \preceq y$

(or equivalently,  $\sqsubseteq$  is included in  $\preceq$ )

# Exercises

$$S = \{a, b, c, d, e, f\}$$

$$a \sqsubseteq b \sqsubseteq d \sqsubseteq f \quad a \sqsubseteq c \sqsubseteq e \sqsubseteq f \quad c \sqsubseteq d$$

Which of the following are linear extensions?

(we write, e.g.,  $abc$  for  $a \preceq b \preceq c$ )

abcdef

abcedf

abdcef

acebdf

acbedf

acefbd

# Linked

Process activities are linked along a value-added chain

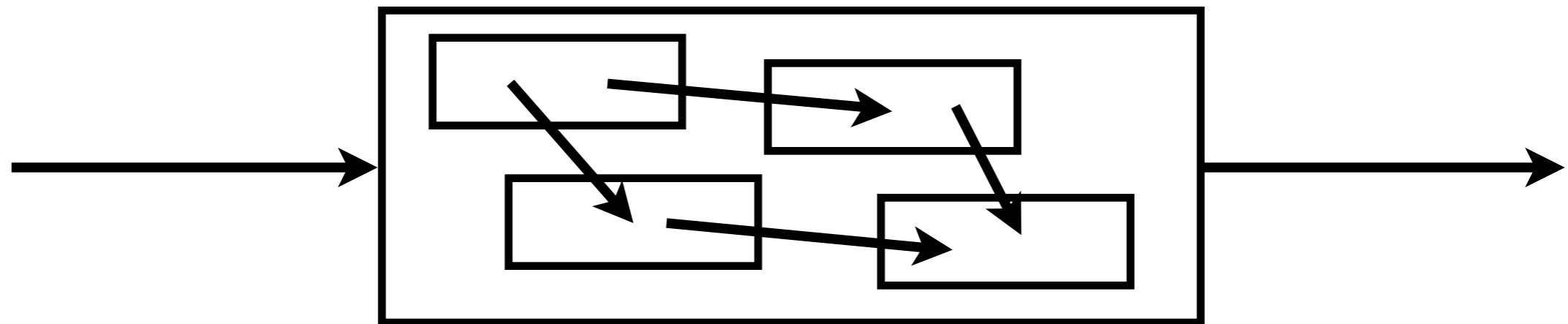

# Customer

The process output has a recipient

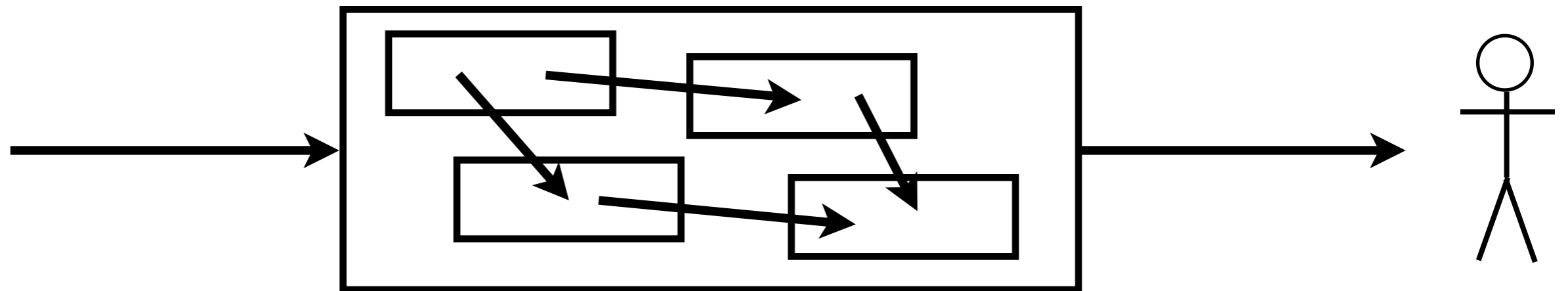



# Measurability

The process output can be evaluated

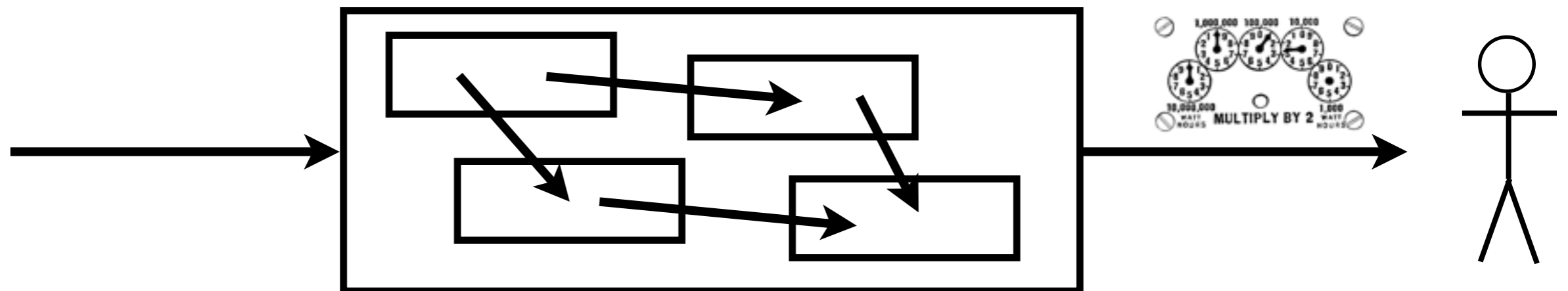

# Ownership

There is one responsible for the performance and continuous improvement of the process

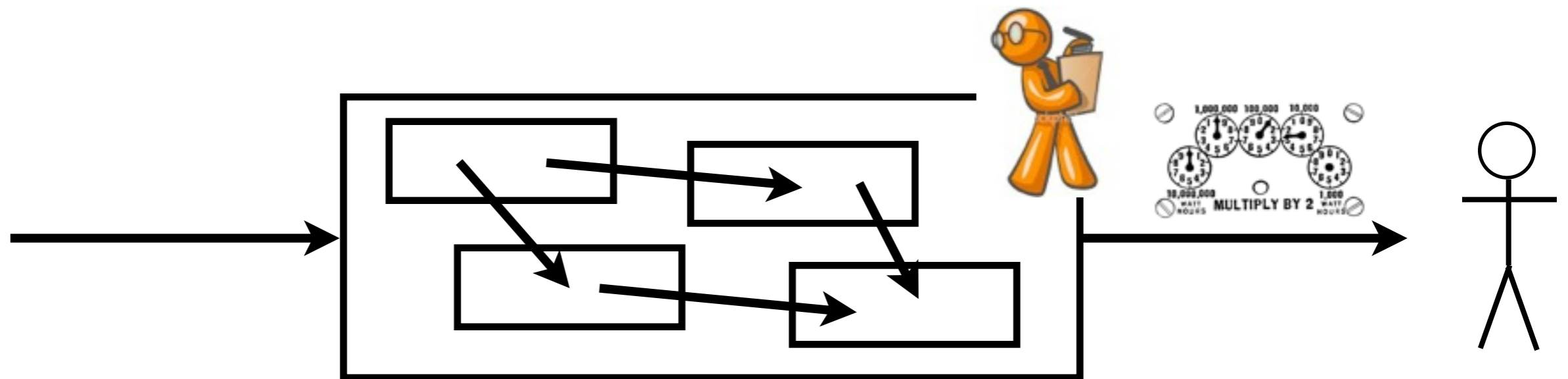

# Cross-functionality

A process can span several functions within and across the organizational structure in which it is embedded

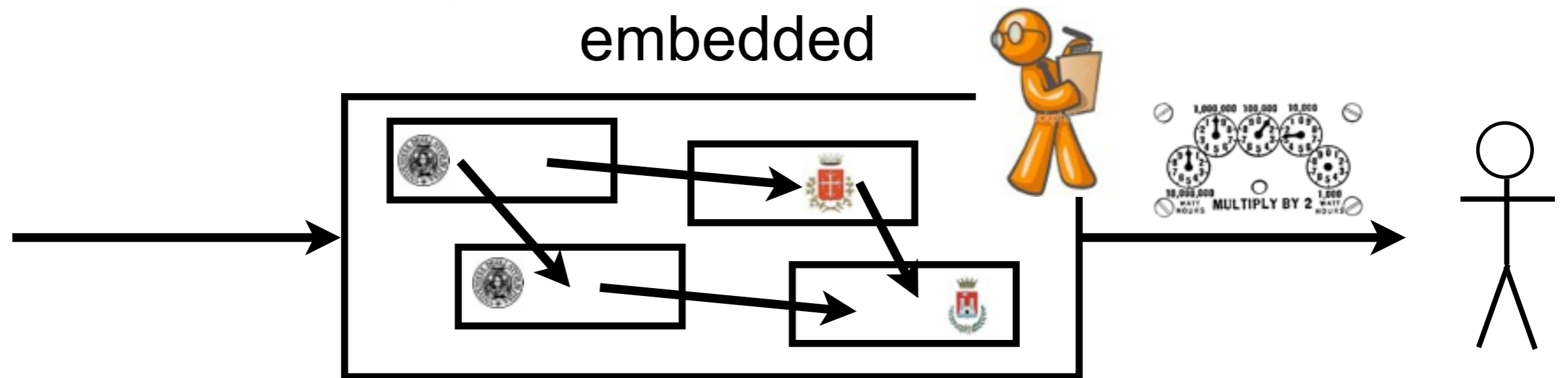

# Some definitions

# Business process

**Definition:** a **business process** consists of a set of activities that are performed in coordination in an organizational and technical environment.

These activities jointly realize a business goal.

Each business process is enacted by a single organization, but it may interact with business processes performed by other organizations.

- *Weske*

# Business process management

**Definition:** **business process management**

includes concepts, methods, and techniques to support the design, administration, configuration, enactment, and analysis of business processes.

- *Weske*

# Business process management

The basis of business process management is the explicit representation of business processes with their **activities** and the **execution constraints** between them

Business processes can then be subject to **analysis, improvement, and enactment**

# Business process management system

**Definition:** **business process management system** is a generic software system that is driven by explicit process representations to coordinate the enactment of business processes.

- *Weske*



# Business process model

**Definition:** **business process model** consists of a set of activity models and execution constraints between them.

- *Weske*

# Business process instance

**Definition:** **business process instance**

represents a concrete case in the operational business of a company, consisting of activity instances.

- *Weske*

# Model and instances

Each business process model acts as a blueprint for a set of business process instances

Each activity model acts as a blueprint for a set of activity instances



# Abuse of notation

If no confusion is possible, the term business process is used to refer to either business process models or business process instances

Analogously, the term activity is used to refer to either activity models or activity instances

# Process-driven software

Business process models are the main artefact for implementing business processes

This implementation can be done by organizational rules and policies, but it can also be done by business process management (software) system

In this case the software system is driven by explicit process representations

# Process representations

Visual representations: diagrams and charts  
(few conventions, intuitive)

Languages: precise syntax  
(process dialects, XML)

Models: precise semantics  
(Petri nets, YAWL)