

Business Processes Modelling

MPB (6 cfu, 295AA)

Roberto Bruni

<http://www.di.unipi.it/~bruni>

11 - Incidence matrices



Object

We give a matrix-based representation of Petri nets and their computations

Free Choice Nets (book, optional reading)

<https://www7.in.tum.de/~esparza/bookfc.html>

Digression

Are you familiar with the following concepts?

Vector notation

$$[2 \quad 0 \quad 1] \cdot \begin{bmatrix} 0 \\ 3 \\ 2 \end{bmatrix} =$$

Digression

Are you familiar with the following concepts?

Vector notation

$$[2 \quad 0 \quad 1] \cdot \begin{bmatrix} 0 & 1 \\ 3 & 4 \\ 2 & 2 \end{bmatrix} =$$

Digression

Are you familiar with the following concepts?

Linear algebra

$$\begin{cases} 3x_1 + 2x_2 - 2x_3 = 0 \\ 6x_1 - 4x_2 = 0 \\ 9x_1 - 3x_3 = 0 \end{cases}$$

Digression

Are you familiar with the following concepts?

Linear algebra

$$[x_1 \quad x_2 \quad x_3] \cdot \begin{bmatrix} 3 & 6 & 9 \\ 2 & -4 & 0 \\ -2 & 0 & -3 \end{bmatrix} = [0 \quad 0 \quad 0]$$

$$\begin{cases} 3x_1 + 2x_2 - 2x_3 = 0 \\ 6x_1 - 4x_2 = 0 \\ 9x_1 - 3x_3 = 0 \end{cases}$$

Vectors: notation

Let $E = \{e_1, e_2, \dots, e_n\}$ be a finite set of elements.

Any mapping $v : E \rightarrow \mathbb{Q}$ (or to $\mathbb{N}, \mathbb{Z}, \dots$) can be regarded as a vector:

$$\mathbf{v} = [v(e_1), v(e_2), \dots, v(e_n)]$$

We **do not** use different symbols for row and column vectors:

$$\mathbf{v} = \begin{bmatrix} v(e_1) \\ v(e_2) \\ \vdots \\ v(e_n) \end{bmatrix}$$

Marking as a vector

Any marking $M : P \rightarrow \mathbb{N}$ corresponds to a vector:

$$M = [M(p_1) \quad M(p_2) \quad \dots \quad M(p_n)]$$

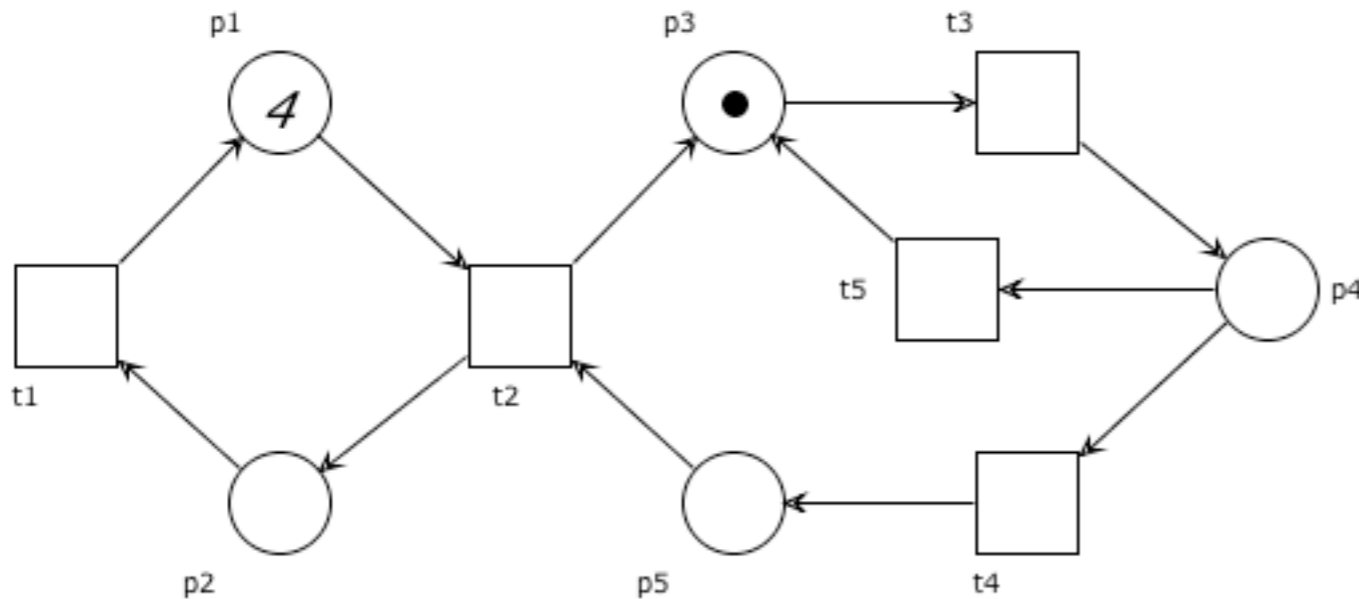

$$M_0 = [4 \quad 0 \quad 1 \quad 0 \quad 0]$$

Vectors: notation

Let \mathbf{v}, \mathbf{w} be two vectors over E

We write $\mathbf{v} \leq \mathbf{w}$ if $v(e) \leq w(e)$ for any $e \in E$

We write $\mathbf{v} < \mathbf{w}$ if $v \leq w$ and $v(e) < w(e)$ for some $e \in E$

We write $\mathbf{v} \prec \mathbf{w}$ if $v(e) < w(e)$ for any $e \in E$

We let $\mathbf{0}$ denote any vector of any length whose entries are all 0

Question time

$$3a + 2b \stackrel{?}{\subseteq} 2a + 3b + c$$

$$[3 \quad 2 \quad 0] \stackrel{?}{\leq} [2 \quad 3 \quad 1]$$

$$3a + 2b \stackrel{?}{\supseteq} 2a + 3b + c$$

$$[3 \quad 2 \quad 0] \stackrel{?}{\geq} [2 \quad 3 \quad 1]$$

$$a + 2b \stackrel{?}{\subset} 2a + 3b$$

$$[1 \quad 2 \quad 0] \stackrel{?}{<} [2 \quad 3 \quad 0]$$

$$[0 \quad 0 \quad 0] \stackrel{?}{\wedge} [2 \quad 0 \quad 1]$$

$$[0 \quad 0 \quad 0] \stackrel{?}{\wedge} [2 \quad 3 \quad 1]$$

Question time

$$3a + 2b \stackrel{?}{\subseteq} 2a + 3b + c \quad \text{No} \quad [3 \ 2 \ 0] \stackrel{?}{\leq} [2 \ 3 \ 1]$$

$$3a + 2b \stackrel{?}{\supseteq} 2a + 3b + c \quad \text{No} \quad [3 \ 2 \ 0] \stackrel{?}{\geq} [2 \ 3 \ 1]$$

$$a + 2b \stackrel{?}{\subset} 2a + 3b \quad \text{Yes} \quad [1 \ 2 \ 0] \stackrel{?}{<} [2 \ 3 \ 0]$$

$$\text{No} \quad [0 \ 0 \ 0] \stackrel{?}{\wedge} [2 \ 0 \ 1]$$

$$\text{Yes} \quad [0 \ 0 \ 0] \stackrel{?}{\wedge} [2 \ 3 \ 1]$$

Computation as a vector transformation

Linear transformations of vectors (spaces) can be expressed by matrix multiplication

Can we express Petri net computations by matrix multiplication?

Key point

The change of the numbers of tokens on a place p caused by the firing of the transition t does not depend on the current marking

It is entirely determined by the net
(i.e., by the flow relation)

Let us have a look at the relative changes for every place and transition...

Possible connections between p and t

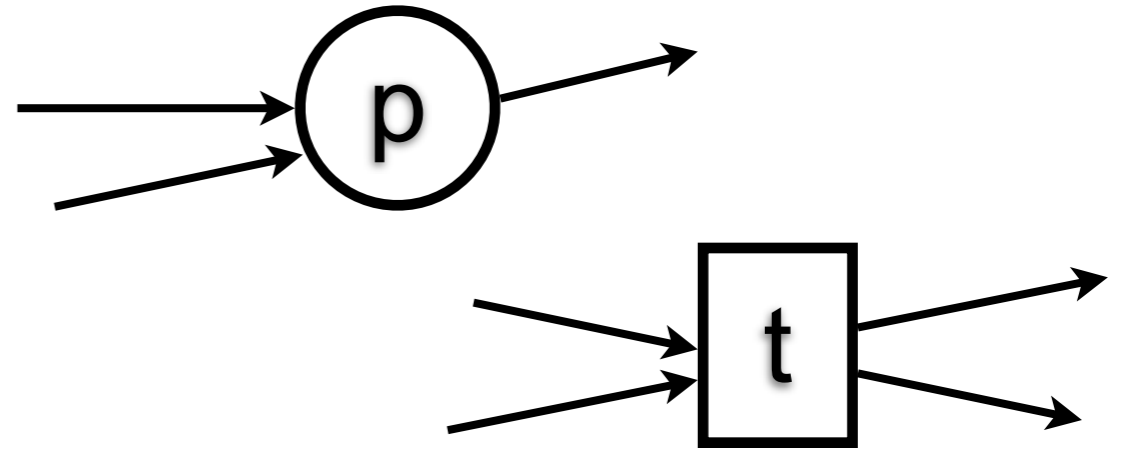

$(p, t) \notin F$ and $(t, p) \notin F$

Place p and transition t are completely unrelated:

- p has no influence on the enabling of t
- firing t does not change the number of tokens in p

Possible connections between p and t

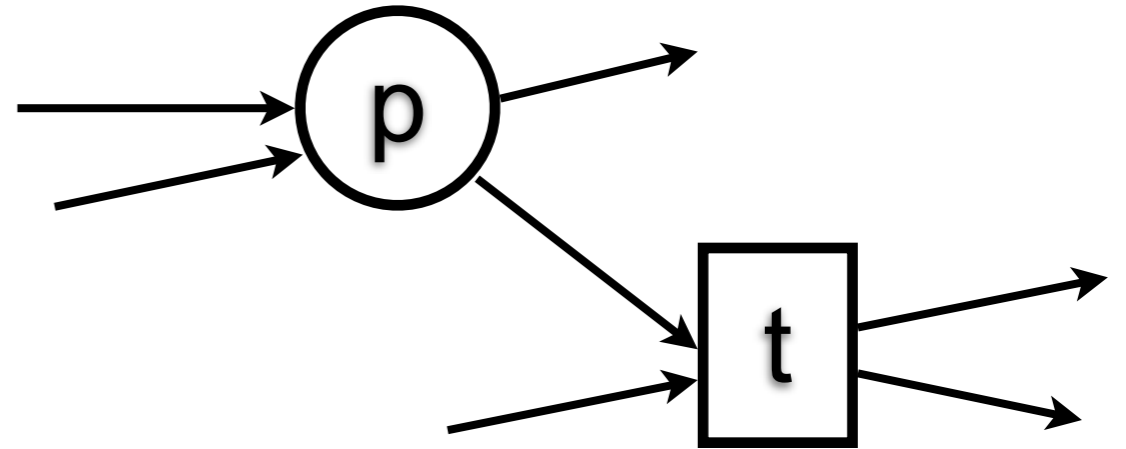

$(p, t) \in F$ and $(t, p) \notin F$

- one token in p is needed to enable t
- firing t reduces by one the number of tokens in p

Possible connections between p and t

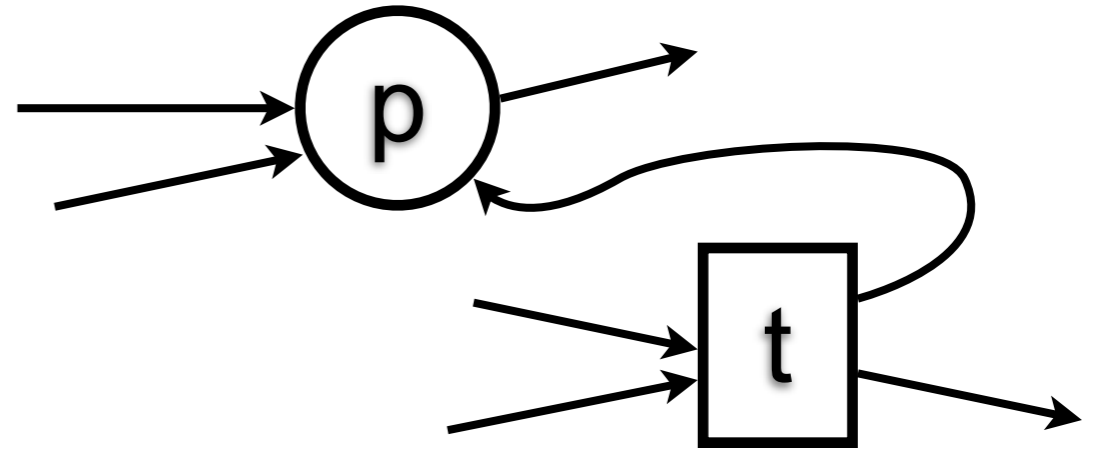

$(p, t) \notin F$ and $(t, p) \in F$

- firing t increases by one the number of tokens in p

Possible connections between p and t

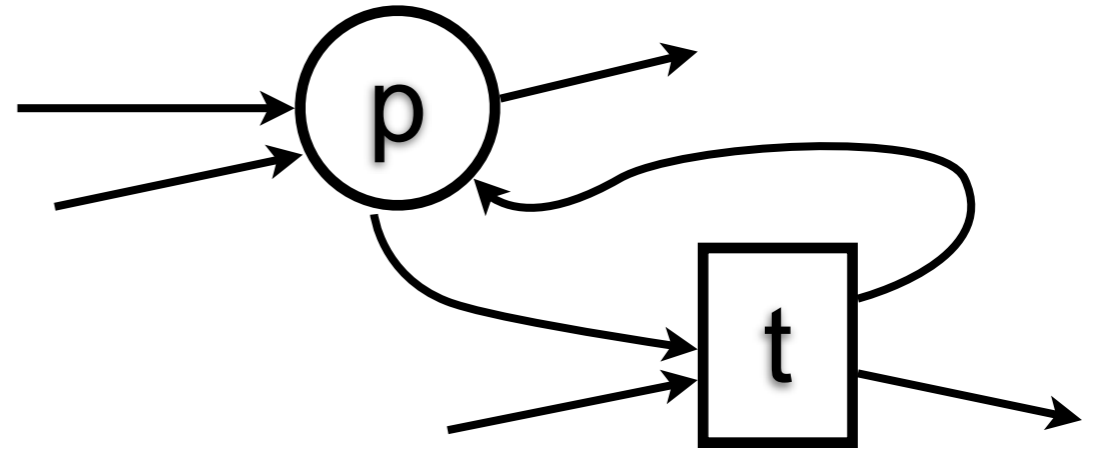

$(p, t) \in F$ and $(t, p) \in F$

- one token in p is needed to enable t
- firing t does not change the number of tokens in p

Incidence matrix

Let $N = (P, T, F)$ be a net.

Its **incidence matrix** $\mathbf{N} : (P \times T) \rightarrow \{-1, 0, 1\}$ is defined as:

$$\mathbf{N}(p, t) = \begin{cases} -1 & \text{if } (p, t) \in F \wedge (t, p) \notin F \\ +1 & \text{if } (p, t) \notin F \wedge (t, p) \in F \\ 0 & \text{otherwise} \\ & ((p, t) \notin F \wedge (t, p) \notin F \text{ or } (p, t) \in F \wedge (t, p) \in F) \end{cases}$$

Matrix view

m columns, one for each transition

n rows,
one for
each place

	t_1	t_2	t_3					...					t_m
p_1		+1	-1										-1
p_2	-1		+1										
p_3		+1											
			+1										
...								...					+1
	+1												
			-1										
													+1
p_n		-1	+1										-1

Column vector t_j

$t_j : P \rightarrow \{-1, 0, 1\}$ such that $t_j(p) = \mathbf{N}(p, t_j)$

	t_1	t_2	t_3	...	t_m
p_1		+1	-1		-1
p_2	-1		+1		
p_3		+1			
			+1		
...				...	+1
	+1				
			-1		
					+1
p_n		-1	+1		-1

Row vector p_i

$p_i : T \rightarrow \{-1, 0, 1\}$
 such that
 $p_i(t) = \mathbf{N}(p_i, t)$

	t_1	t_2	t_3											t_m
p_1		+1	-1											-1
p_2	-1		+1											
p_3		+1												
			+1											
														+1
	+1													
			-1											
														+1
p_n		-1	+1											-1

Example: vending machine

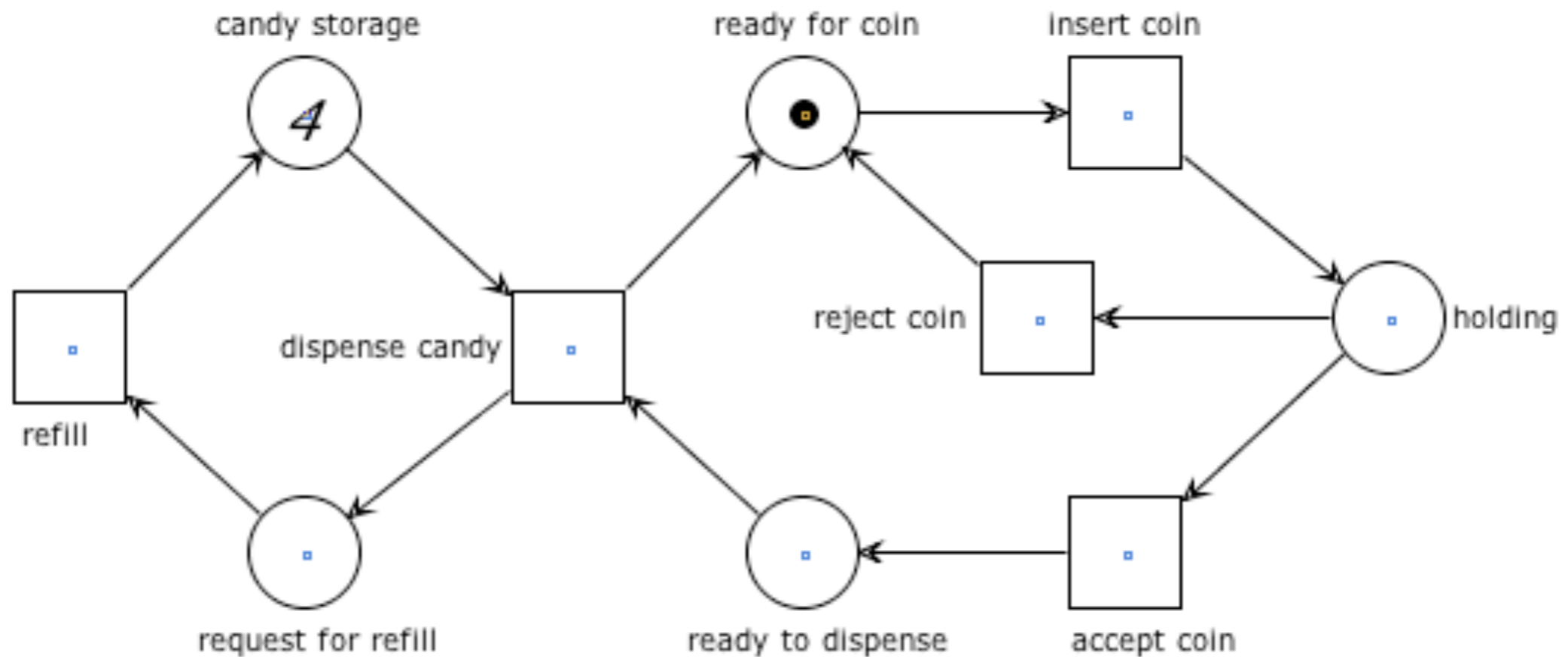

Example: vending machine

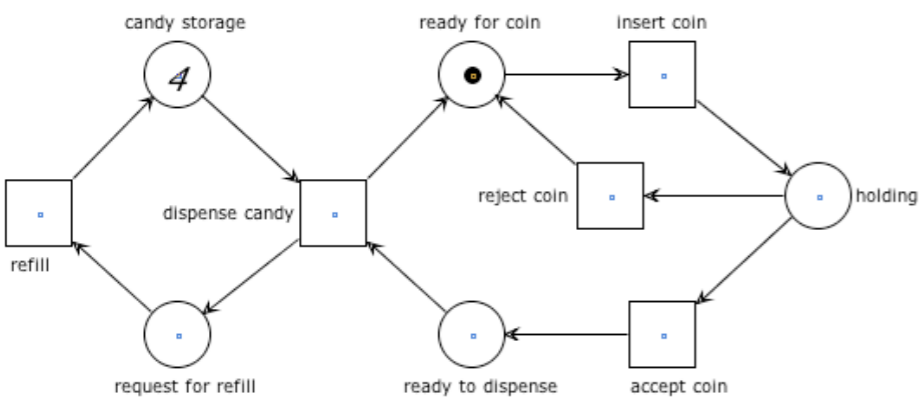

	refill t_1	dispense candy t_2	insert coin t_3	accept coin t_4	reject coin t_5
candy storage p_1					
request for refill p_2					
ready for coin p_3					
holding p_4					
ready to dispense p_5					

Example: vending machine

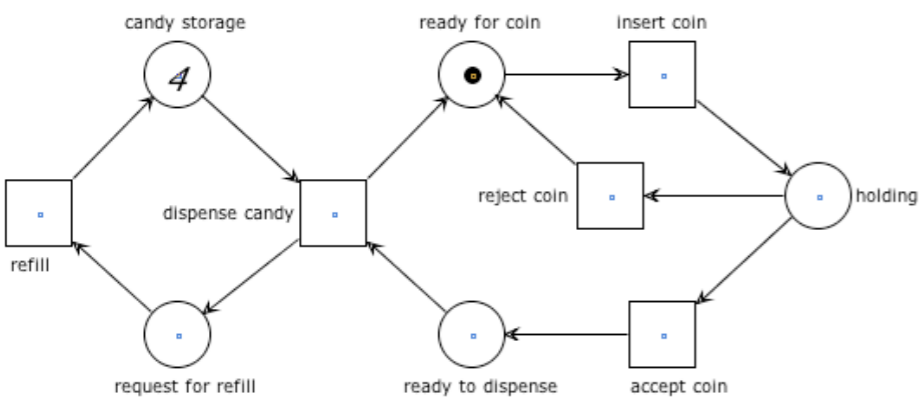

	refill t_1	dispense candy t_2	insert coin t_3	accept coin t_4	reject coin t_5
candy storage p_1	1	-1			
request for refill p_2	-1	1			
ready for coin p_3		1	-1		1
holding p_4			1	-1	-1
ready to dispense p_5		-1		1	

Example: vending machine

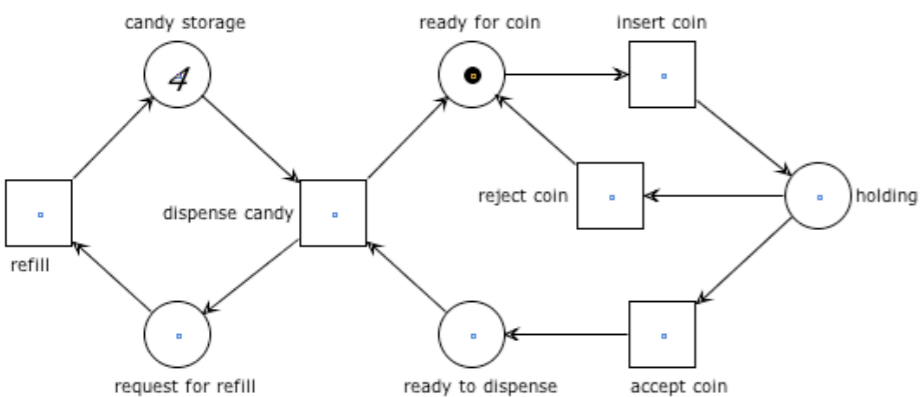

	refill t_1	dispense candy t_2	insert coin t_3	accept coin t_4	reject coin t_5
candy storage p_1	1	-1	0	0	0
request for refill p_2	-1	1	0	0	0
ready for coin p_3	0	1	-1	0	1
holding p_4	0	0	1	-1	-1
ready to dispense p_5	0	-1	0	1	0

Firing, in vector notation

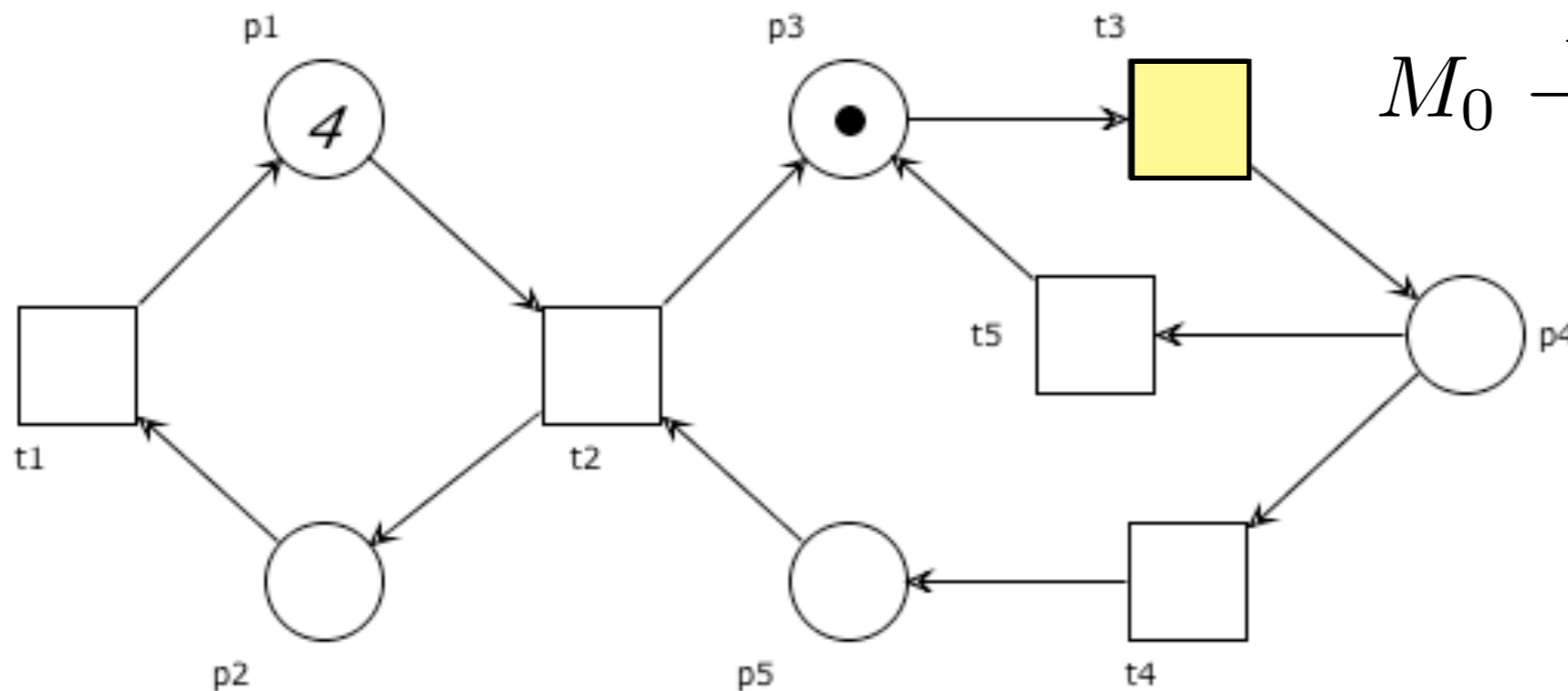

$$M_0 \xrightarrow{t_3} M_1 = 4p_1 + p_4$$

$$\begin{matrix} M_0 \\ \left[\begin{array}{c} 4 \\ 0 \\ 1 \\ 0 \\ 0 \end{array} \right] \end{matrix}
 +
 \begin{matrix} t_3 \\ \left[\begin{array}{c} 0 \\ 0 \\ -1 \\ 1 \\ 0 \end{array} \right] \end{matrix}
 =
 \begin{matrix} M_1 \\ \left[\begin{array}{c} 4 \\ 0 \\ 0 \\ 1 \\ 0 \end{array} \right] \end{matrix}$$

Firing, in vector notation

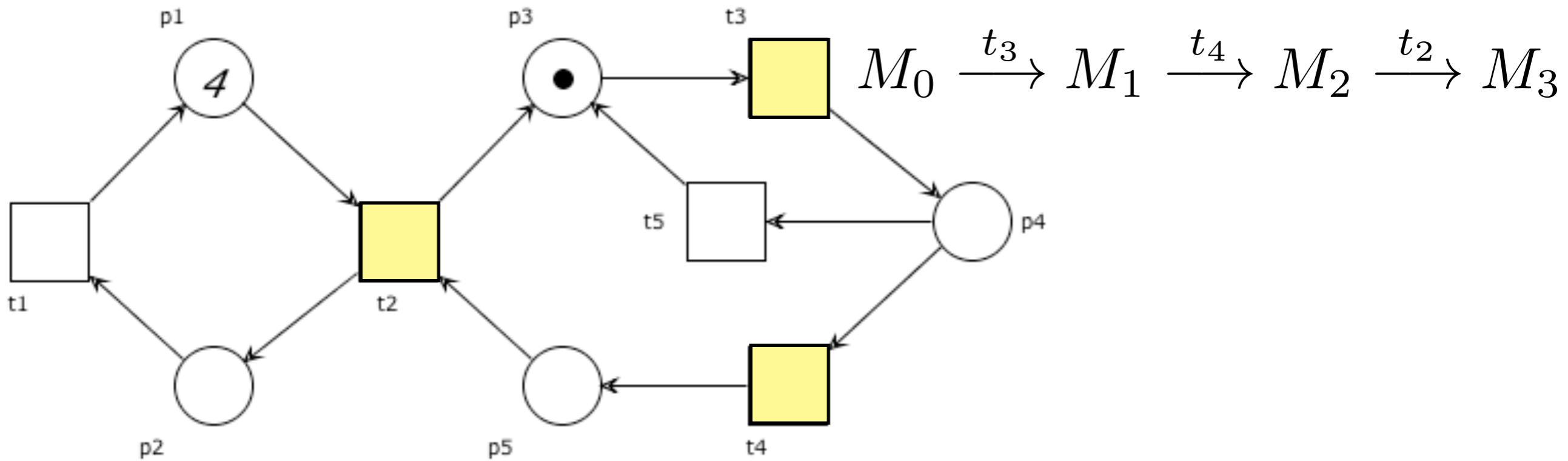

$$\begin{matrix} M_0 \\ \left[\begin{array}{c} 4 \\ 0 \\ 1 \\ 0 \\ 0 \end{array} \right] \end{matrix} + \begin{matrix} t_3 \\ \left[\begin{array}{c} 0 \\ 0 \\ -1 \\ 1 \\ 0 \end{array} \right] \end{matrix} = \begin{matrix} M_1 \\ \left[\begin{array}{c} 4 \\ 0 \\ 0 \\ 1 \\ 0 \end{array} \right] \end{matrix}$$

Firing, in vector notation

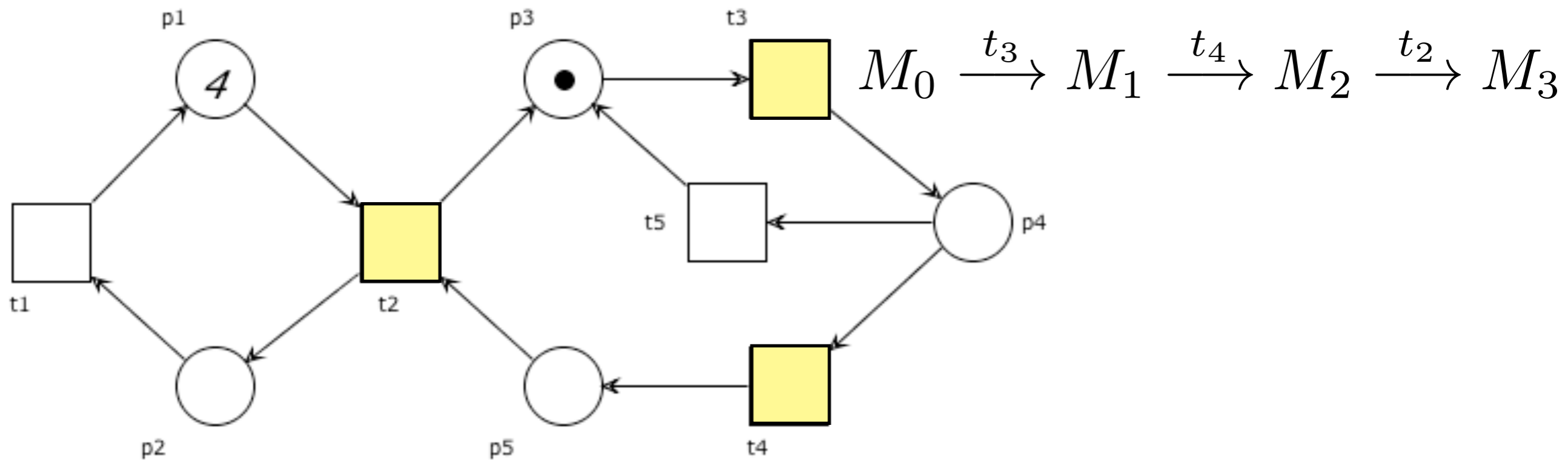

$$\begin{matrix} M_1 \\ \left[\begin{array}{c} 4 \\ 0 \\ 0 \\ 1 \\ 0 \end{array} \right] \end{matrix} + \begin{matrix} t_4 \\ \left[\begin{array}{c} 0 \\ 0 \\ 0 \\ -1 \\ 1 \end{array} \right] \end{matrix} = \begin{matrix} M_2 \\ \left[\begin{array}{c} 4 \\ 0 \\ 0 \\ 0 \\ 1 \end{array} \right] \end{matrix}$$

Firing, in vector notation

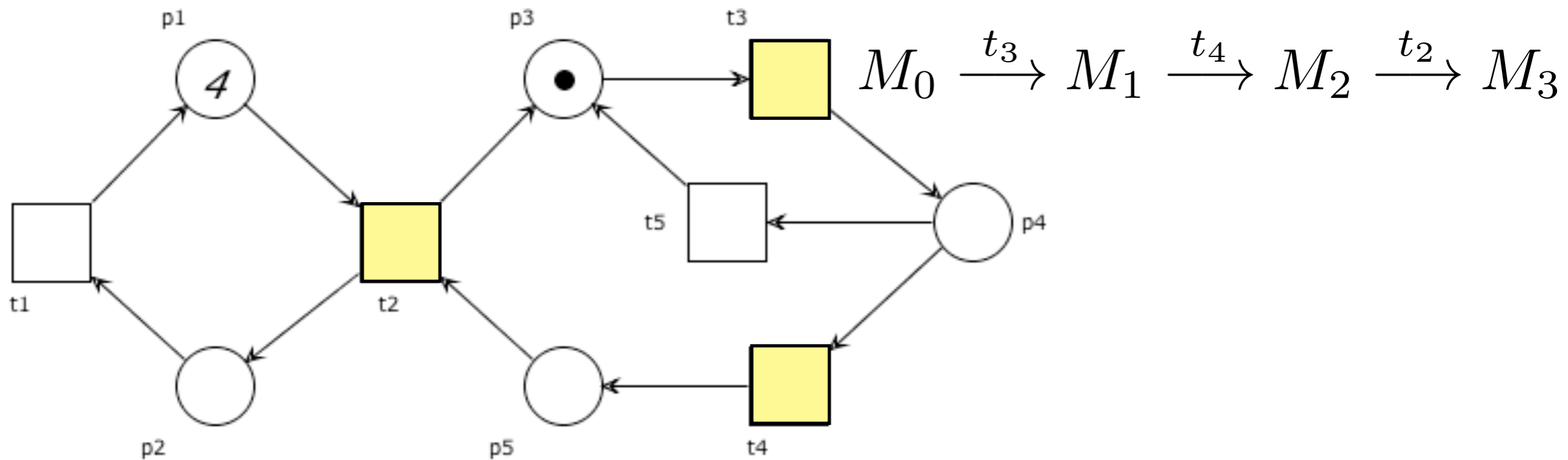

$$\begin{bmatrix} M_2 \\ 4 \\ 0 \\ 0 \\ 0 \\ 1 \end{bmatrix} + \begin{bmatrix} t_2 \\ -1 \\ 1 \\ 1 \\ 0 \\ -1 \end{bmatrix} = \begin{bmatrix} M_3 \\ 3 \\ 1 \\ 1 \\ 0 \\ 0 \end{bmatrix}$$

Products

Let \mathbf{x}, \mathbf{y} be two vectors of equal length n (written $|\mathbf{x}| = |\mathbf{y}| = n$)

We define their scalar product by

$$\mathbf{x} \cdot \mathbf{y} = \sum_{i=1}^n x_i y_i$$

$$\begin{bmatrix} x_1 & x_2 & \dots & x_n \end{bmatrix} \cdot \begin{bmatrix} y_1 \\ y_2 \\ \vdots \\ y_n \end{bmatrix} = x_1 y_1 + x_2 y_2 + \dots + x_n y_n$$

Products: example

$$\begin{bmatrix} 0 & 1 & -1 & 0 & 1 \end{bmatrix} \cdot \begin{bmatrix} 1 \\ 1 \\ 2 \\ 0 \\ 1 \end{bmatrix} =$$

Products: example

$$\begin{bmatrix} 0 & 1 & -1 & 0 & 1 \end{bmatrix} \cdot \begin{bmatrix} 1 \\ 1 \\ 2 \\ 0 \\ 1 \end{bmatrix} = (0 \cdot 1) +$$

Products: example

$$\begin{bmatrix} 0 & 1 & -1 & 0 & 1 \end{bmatrix} \cdot \begin{bmatrix} 1 \\ 1 \\ 2 \\ 0 \\ 1 \end{bmatrix} = (0 \cdot 1) + (1 \cdot 1) +$$

Products: example

$$[0 \quad 1 \quad \boxed{-1} \quad 0 \quad 1] \cdot \begin{bmatrix} 1 \\ 1 \\ \boxed{2} \\ 0 \\ 1 \end{bmatrix} = (0 \cdot 1) + (1 \cdot 1) + (-1 \cdot 2) +$$

Products: example

$$[0 \quad 1 \quad -1 \quad \boxed{0} \quad 1] \cdot \begin{bmatrix} 1 \\ 1 \\ 2 \\ \boxed{0} \\ 1 \end{bmatrix} = (0 \cdot 1) + (1 \cdot 1) + (-1 \cdot 2) + (0 \cdot 0) +$$

Products: example

$$\begin{bmatrix} 0 & 1 & -1 & 0 & 1 \end{bmatrix} \cdot \begin{bmatrix} 1 \\ 1 \\ 2 \\ 0 \\ 1 \end{bmatrix} = (0 \cdot 1) + (1 \cdot 1) + (-1 \cdot 2) + (0 \cdot 0) + (1 \cdot 1)$$

Products: example

$$[0 \quad 1 \quad -1 \quad 0 \quad 1] \cdot \begin{bmatrix} 1 \\ 1 \\ 2 \\ 0 \\ 1 \end{bmatrix} = (0 \cdot 1) + (1 \cdot 1) + (-1 \cdot 2) + (0 \cdot 0) + (1 \cdot 1) = 0 + 1 - 2 + 0 + 1$$

Products: example

$$\begin{bmatrix} 0 & 1 & -1 & 0 & 1 \end{bmatrix} \cdot \begin{bmatrix} 1 \\ 1 \\ 2 \\ 0 \\ 1 \end{bmatrix} = (0 \cdot 1) + (1 \cdot 1) + (-1 \cdot 2) + (0 \cdot 0) + (1 \cdot 1) = 0 + 1 - 2 + 0 + 1 = 0$$

Products

Let $\mathbf{x}_1, \mathbf{x}_2, \dots, \mathbf{x}_k, \mathbf{y}$ be all vectors of equal length

Let X be a $(k \times n)$ -matrix whose i -th row is \mathbf{x}_i

We define the product $X \cdot \mathbf{y}$ as the (column) vector where

$$(X \cdot \mathbf{y})_i = \mathbf{x}_i \cdot \mathbf{y}$$

$$\begin{bmatrix} \square & \square & \square & \square \\ \square & \square & \square & \square \\ \square & \square & \square & \square \\ \square & \square & \square & \square \end{bmatrix} \cdot \begin{bmatrix} \square \\ \square \\ \square \\ \square \end{bmatrix} = \begin{matrix} \text{rows} \\ \begin{bmatrix} \mathbf{x}_1 \\ \mathbf{x}_2 \\ \vdots \\ \mathbf{x}_k \end{bmatrix} \end{matrix} \cdot \begin{bmatrix} y_1 \\ y_2 \\ \vdots \\ y_n \end{bmatrix} = \begin{bmatrix} \mathbf{x}_1 \cdot \mathbf{y} \\ \mathbf{x}_2 \cdot \mathbf{y} \\ \vdots \\ \mathbf{x}_k \cdot \mathbf{y} \end{bmatrix} \begin{bmatrix} \square \\ \square \\ \square \\ \square \end{bmatrix}$$

Products: example

$$\begin{bmatrix} 1 & -1 & 0 & 0 & 0 \\ -1 & 1 & 0 & 0 & 0 \\ 0 & 1 & -1 & 0 & 1 \\ 0 & 0 & 1 & -1 & -1 \\ 0 & -1 & 0 & 1 & 0 \end{bmatrix} \cdot \begin{bmatrix} 1 \\ 1 \\ 2 \\ 0 \\ 1 \end{bmatrix} = \begin{bmatrix} 1 - 1 \\ -1 + 1 \\ 1 - 2 + 1 \\ 2 - 1 \\ -1 \end{bmatrix}$$

Products: example

$$\begin{bmatrix} 1 & -1 & 0 & 0 & 0 \\ -1 & 1 & 0 & 0 & 0 \\ 0 & 1 & -1 & 0 & 1 \\ 0 & 0 & 1 & -1 & -1 \\ 0 & -1 & 0 & 1 & 0 \end{bmatrix} \cdot \begin{bmatrix} 1 \\ 1 \\ 2 \\ 0 \\ 1 \end{bmatrix} = \begin{bmatrix} 1 - 1 \\ -1 + 1 \\ 1 - 2 + 1 \\ 2 - 1 \\ -1 \end{bmatrix}$$

Products: example

$$\begin{bmatrix} 1 & -1 & 0 & 0 & 0 \\ -1 & 1 & 0 & 0 & 0 \\ 0 & 1 & -1 & 0 & 1 \\ 0 & 0 & 1 & -1 & -1 \\ 0 & -1 & 0 & 1 & 0 \end{bmatrix} \cdot \begin{bmatrix} 1 \\ 1 \\ 2 \\ 0 \\ 1 \end{bmatrix} = \begin{bmatrix} 1 - 1 \\ -1 + 1 \\ 1 - 2 + 1 \\ 2 - 1 \\ -1 \end{bmatrix}$$

Products: example

$$\begin{bmatrix} 1 & -1 & 0 & 0 & 0 \\ -1 & 1 & 0 & 0 & 0 \\ 0 & 1 & -1 & 0 & 1 \\ 0 & 0 & 1 & -1 & -1 \\ 0 & -1 & 0 & 1 & 0 \end{bmatrix} \cdot \begin{bmatrix} 1 \\ 1 \\ 2 \\ 0 \\ 1 \end{bmatrix} = \begin{bmatrix} 1 - 1 \\ -1 + 1 \\ 1 - 2 + 1 \\ 2 - 1 \\ -1 \end{bmatrix}$$

Products: example

$$\begin{bmatrix} 1 & -1 & 0 & 0 & 0 \\ -1 & 1 & 0 & 0 & 0 \\ 0 & 1 & -1 & 0 & 1 \\ 0 & 0 & 1 & -1 & -1 \\ 0 & -1 & 0 & 1 & 0 \end{bmatrix} \cdot \begin{bmatrix} 1 \\ 1 \\ 2 \\ 0 \\ 1 \end{bmatrix} = \begin{bmatrix} 1 - 1 \\ -1 + 1 \\ 1 - 2 + 1 \\ 2 - 1 \\ -1 \end{bmatrix}$$

Products: example

$$\begin{bmatrix} 1 & -1 & 0 & 0 & 0 \\ -1 & 1 & 0 & 0 & 0 \\ 0 & 1 & -1 & 0 & 1 \\ 0 & 0 & 1 & -1 & -1 \\ 0 & -1 & 0 & 1 & 0 \end{bmatrix} \cdot \begin{bmatrix} 1 \\ 1 \\ 2 \\ 0 \\ 1 \end{bmatrix} = \begin{bmatrix} 1 - 1 \\ -1 + 1 \\ 1 - 2 + 1 \\ 2 - 1 \\ -1 \end{bmatrix}$$

Products: example

$$\begin{bmatrix} 1 & -1 & 0 & 0 & 0 \\ -1 & 1 & 0 & 0 & 0 \\ 0 & 1 & -1 & 0 & 1 \\ 0 & 0 & 1 & -1 & -1 \\ 0 & -1 & 0 & 1 & 0 \end{bmatrix} \cdot \begin{bmatrix} 1 \\ 1 \\ 2 \\ 0 \\ 1 \end{bmatrix} = \begin{bmatrix} 1 - 1 \\ -1 + 1 \\ 1 - 2 + 1 \\ 2 - 1 \\ -1 \end{bmatrix}$$

Products: example

$$\begin{bmatrix} 1 & -1 & 0 & 0 & 0 \\ -1 & 1 & 0 & 0 & 0 \\ 0 & 1 & -1 & 0 & 1 \\ 0 & 0 & 1 & -1 & -1 \\ 0 & -1 & 0 & 1 & 0 \end{bmatrix} \cdot \begin{bmatrix} 1 \\ 1 \\ 2 \\ 0 \\ 1 \end{bmatrix} = \begin{bmatrix} 1 - 1 \\ -1 + 1 \\ 1 - 2 + 1 \\ 2 - 1 \\ -1 \end{bmatrix} = \begin{bmatrix} 0 \\ 0 \\ 0 \\ 1 \\ -1 \end{bmatrix}$$

Products

Let $\mathbf{x}, \mathbf{y}_1, \mathbf{y}_2, \dots, \mathbf{y}_k$ be all vectors of equal length

Let Y be a $(n \times k)$ -matrix whose i -th column is \mathbf{y}_i

We define the product $\mathbf{x} \cdot Y$ as the (row) vector where

$$(\mathbf{x} \cdot Y)_i = \mathbf{x} \cdot \mathbf{y}_i$$

$$[x_1 \ x_2 \ \dots \ x_n] \cdot \begin{matrix} \text{columns} \\ [y_1 \ y_2 \ \dots \ y_k] \end{matrix} = [x \cdot y_1 \quad x \cdot y_2 \quad \dots \quad x \cdot y_k]$$

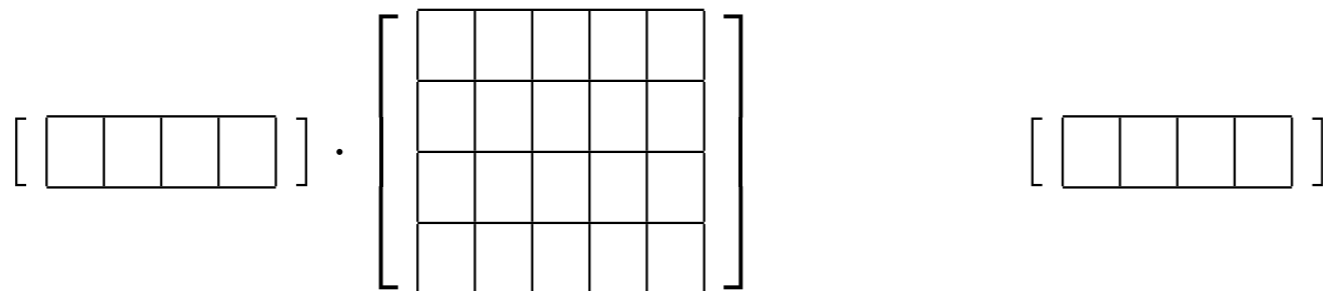

Vector perspective

Let $P = \{ p_1, \dots, p_n \}$ and $T = \{ t_1, \dots, t_m \}$

The net (P, T, F) can be seen as a matrix $(n \times m)$

A marking is a vector of length n

But we miss an ingredient:

can any firing sequence be seen as a vector?

Parikh vectors of transition sequences

Let $N = (P, T, F)$ be a net and $\sigma \in T^*$ a finite sequence of transitions.

The **Parikh vector**

$$\vec{\sigma} : T \rightarrow \mathbb{N}$$

of σ maps every $t \in T$ to the number of its occurrences in σ .

Parikh vector of a firing

As a special case, for a sequence $\sigma = t$ (one single transition):

$$\vec{t} = \begin{bmatrix} 0 & \dots & 0 & 1 & 0 & \dots & 0 \\ t_1 & & & t & & & t_m \end{bmatrix}$$

Recursive definition of Parikh vector

$$\vec{\epsilon} = \mathbf{0}$$

$$\vec{t} = \begin{bmatrix} 0 & \dots & 0 & 1 & 0 & \dots & 0 \\ t_1 & & & t & & & t_m \end{bmatrix}$$

$$\vec{\sigma t} = \vec{\sigma} + \vec{t}$$

Parikh vector: example

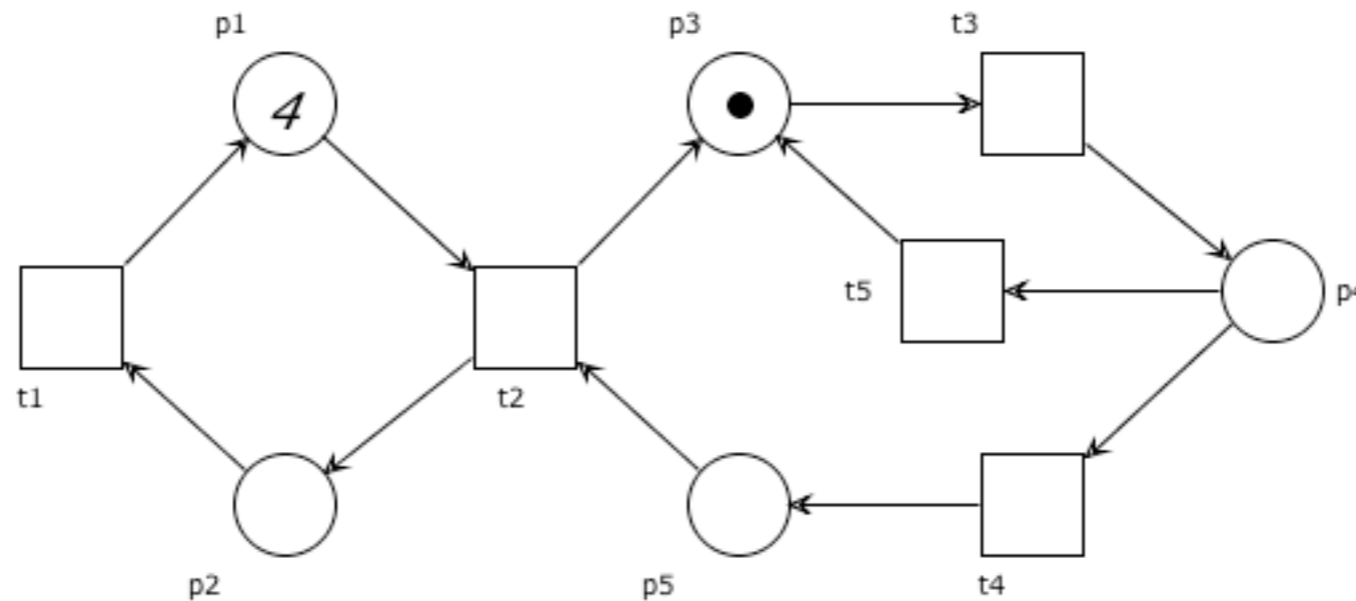

$$M_0 = 4p_1 + p_3$$

$$M_0 \xrightarrow{\sigma = t_3 t_5 t_3 t_4 t_2} 3p_1 + p_2 + p_3 \quad \vec{\sigma} = [0 \quad 1 \quad 2 \quad 1 \quad 1]$$

$$M_0 \xrightarrow{\sigma' = t_3 t_4 t_2 t_3 t_4 t_2 t_3 t_5 t_3} 2p_1 + 2p_2 + p_4 \quad \vec{\sigma}' = [0 \quad 2 \quad 4 \quad 2 \quad 1]$$

First fact

$$\mathbf{N} \cdot \vec{t}_j = t_j$$

	t_1	t_j	t_m	
p_1				0 t_1
				0
				1 t_j
				0
p_n				0 t_m

Second fact

$$\mathbf{N} \cdot \vec{t}_j = t_j$$

If $M \xrightarrow{t} M'$ then $M' = M + \mathbf{t}$

Consequence

$$\mathbf{N} \cdot \vec{t}_j = t_j$$

If $M \xrightarrow{t} M'$ then $M' = M + \mathbf{t}$

If $M \xrightarrow{t} M'$ then $M' = M + \mathbf{N} \cdot \vec{t}$

Marking equation lemma

Lemma: If $M \xrightarrow{\sigma} M'$ then $M' = M + \mathbf{N} \cdot \vec{\sigma}$

Marking equation lemma

Lemma: If $M \xrightarrow{\sigma} M'$ then $M' = M + \mathbf{N} \cdot \vec{\sigma}$

The proof is by induction on the length of σ

base ($\sigma = \epsilon$): and therefore $M' = M$. The equality holds trivially, because $\vec{\sigma} = \mathbf{0}$

induction ($\sigma = \sigma' t$ for some sequence σ' and transition t):

$$\begin{aligned} \text{Let } M \xrightarrow{\sigma'} M'' \xrightarrow{t} M'. \text{ We have: } M' &= M'' + \mathbf{t} \\ &= M'' + \mathbf{N} \cdot \vec{t} \\ \text{(inductive hyp. } M'' = M + \mathbf{N} \cdot \vec{\sigma}') &= M + \mathbf{N} \cdot \vec{\sigma}' + \mathbf{N} \cdot \vec{t} \\ &= M + \mathbf{N} \cdot (\vec{\sigma}' + \vec{t}) \\ &= M + \mathbf{N} \cdot (\vec{\sigma' t}) \\ &= M + \mathbf{N} \cdot \vec{\sigma} \end{aligned}$$

Marking equation: example

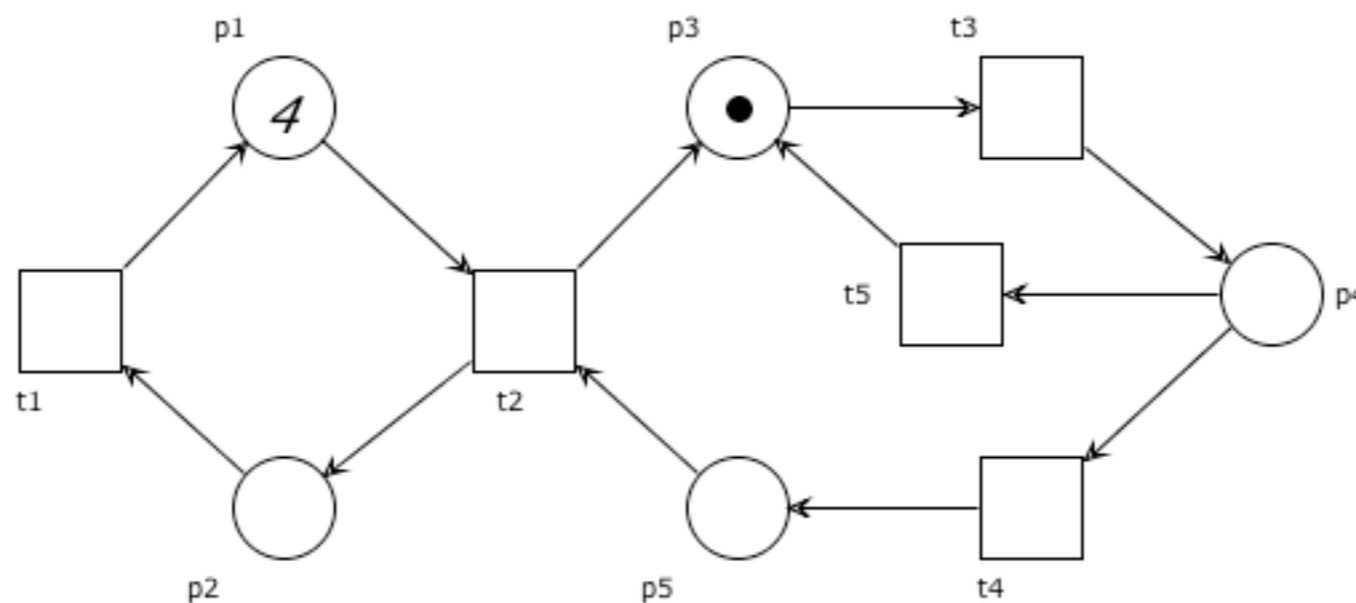

$$M_0 = [4 \quad 0 \quad 1 \quad 0 \quad 0]$$

Marking equation: example

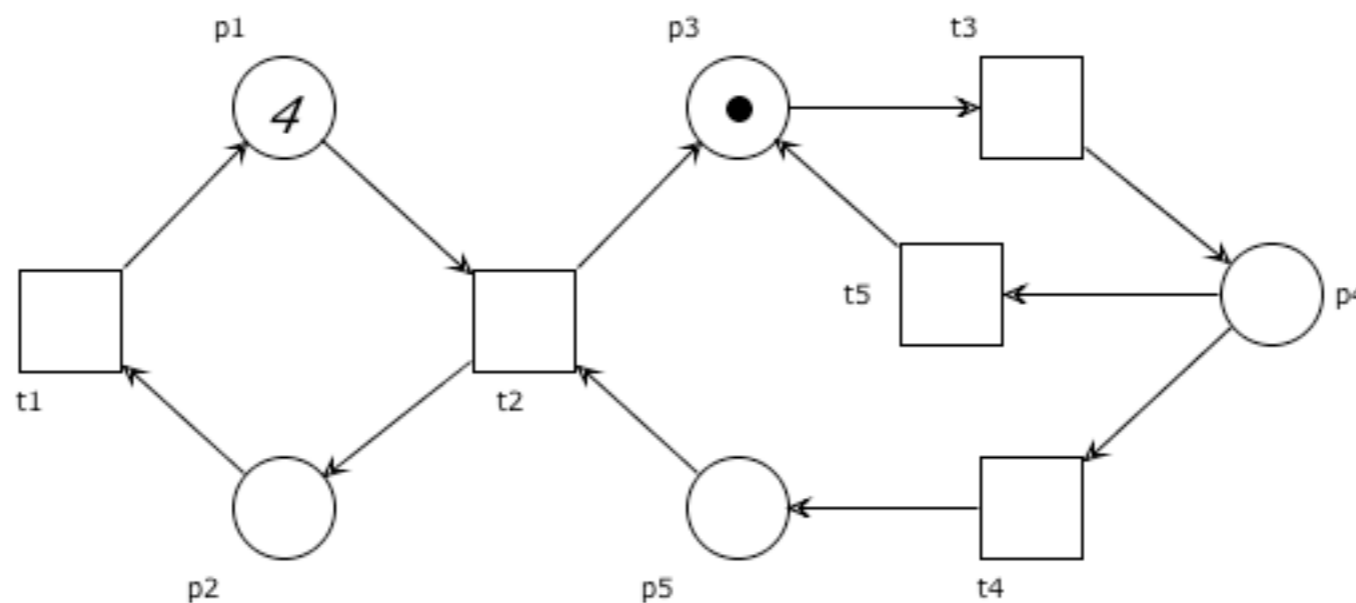

$$M_0 = [4 \quad 0 \quad 1 \quad 0 \quad 0] \quad \sigma = t_3 t_5 t_3 t_4 t_2$$

Marking equation: example

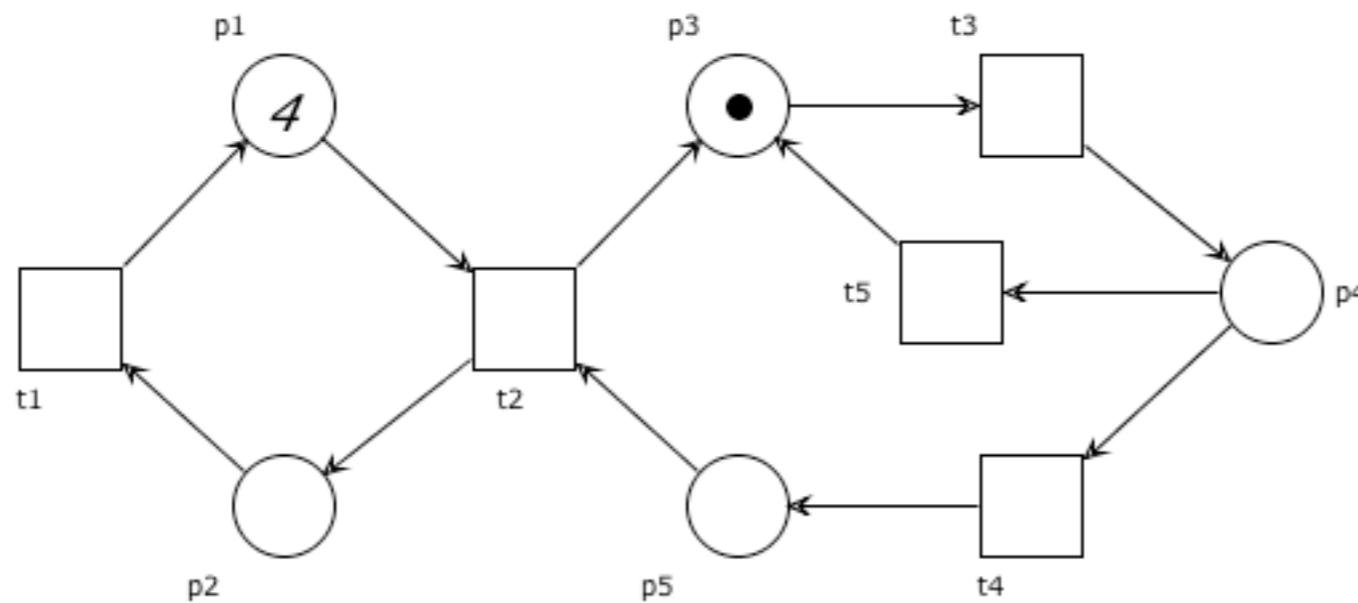

$$M_0 = [4 \quad 0 \quad 1 \quad 0 \quad 0] \quad \sigma = t_3 t_5 t_3 t_4 t_2 \quad \vec{\sigma} = [0 \quad 1 \quad 2 \quad 1 \quad 1]$$

Marking equation: example

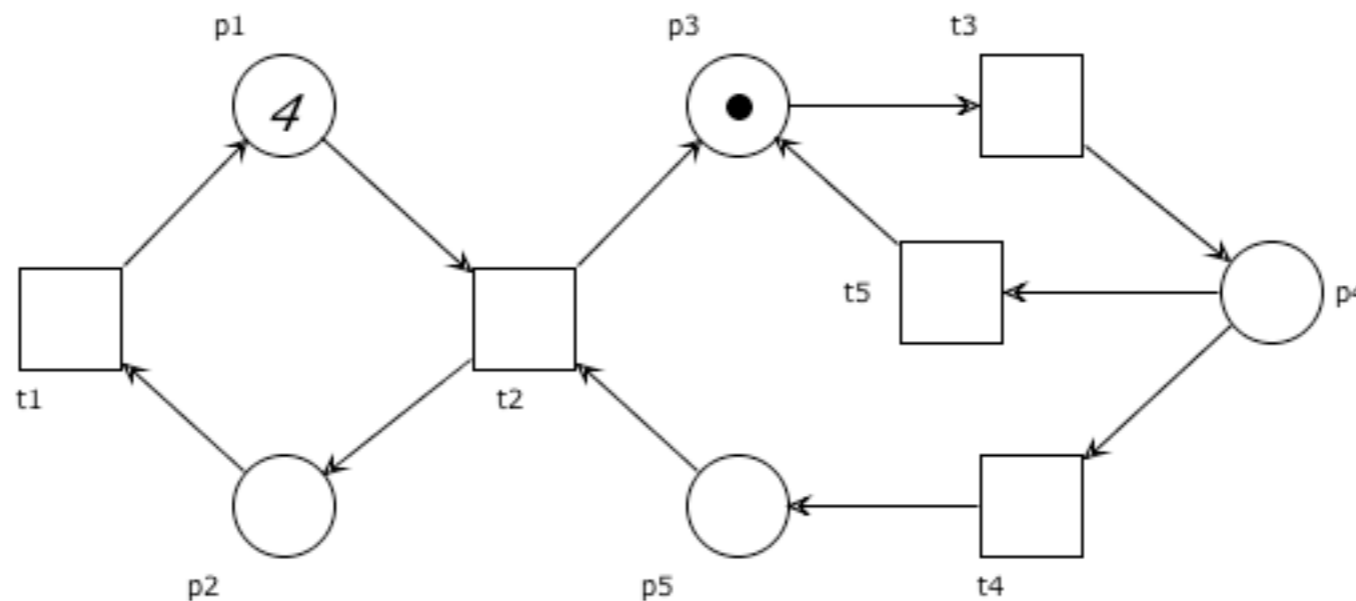

$$M_0 = [4 \quad 0 \quad 1 \quad 0 \quad 0] \quad \sigma = t_3 t_5 t_3 t_4 t_2 \quad \vec{\sigma} = [0 \quad 1 \quad 2 \quad 1 \quad 1]$$

$$\begin{array}{c} M_0 \\ \left[\begin{array}{c} 4 \\ 0 \\ 1 \\ 0 \\ 0 \end{array} \right] \end{array} + \begin{array}{c} N \\ \left[\begin{array}{cccccc} 1 & -1 & 0 & 0 & 0 \\ -1 & 1 & 0 & 0 & 0 \\ 0 & 1 & -1 & 0 & 1 \\ 0 & 0 & 1 & -1 & -1 \\ 0 & -1 & 0 & 1 & 0 \end{array} \right] \cdot \begin{array}{c} \vec{\sigma} \\ \left[\begin{array}{c} 0 \\ 1 \\ 2 \\ 1 \\ 1 \end{array} \right] \end{array} = \begin{array}{c} \\ \left[\begin{array}{c} 3 \\ 1 \\ 1 \\ 0 \\ 0 \end{array} \right] \end{array}$$

Marking equation lemma: consequences

The marking reached by any occurrence sequence only depends on the number of occurrences of each transition

It does not depend on the order in which transitions occur

Every fireable permutation of the same transitions leads to the same marking

Monotonicity lemma (1)

Lemma: If $M \xrightarrow{\sigma} M'$ then $M + L \xrightarrow{\sigma} M' + L$ for any L

Monotonicity lemma (1)

Lemma: If $M \xrightarrow{\sigma} M'$ then $M + L \xrightarrow{\sigma} M' + L$ for any L

The proof is by induction on the length of σ

base ($\sigma = \epsilon$): the empty sequence is always enabled, at any marking

induction ($\sigma = \sigma' t$ for some sequence σ' and transition t):

Let $M \xrightarrow{\sigma'} M'' \xrightarrow{t} M'$.

By the marking equation lemma: $M' = M'' + \mathbf{N} \cdot \vec{t}$

By the induction hypothesis $M + L \xrightarrow{\sigma'} M'' + L$

Moreover, $M'' + L \xrightarrow{t}$ because $M'' \xrightarrow{t}$.

By the marking equation lemma: $M'' + L \xrightarrow{t} M'' + L + \mathbf{N} \cdot \vec{t} = M' + L$

Monotonicity lemma: example

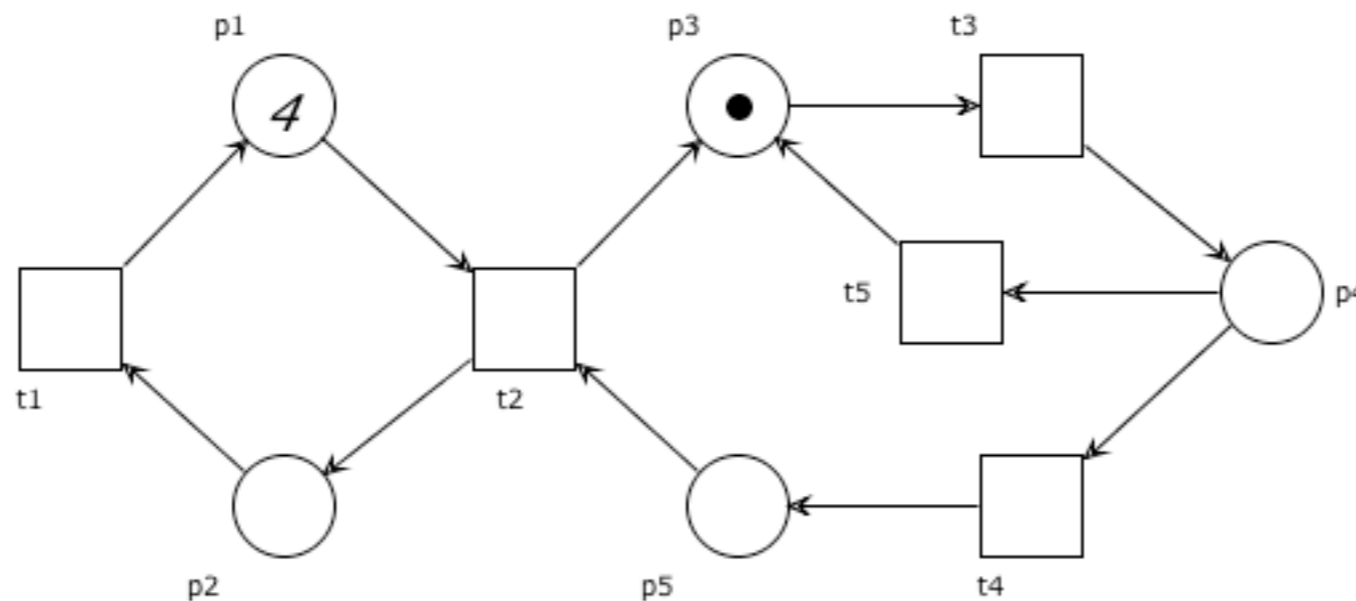

$$M_0 = [4 \quad 0 \quad 1 \quad 0 \quad 0] \quad \sigma = t_3 t_5 t_3 t_4 t_2 \quad \vec{\sigma} = [0 \quad 1 \quad 2 \quad 1 \quad 1]$$

$$M = M_0 + N \cdot \vec{\sigma} = [3 \quad 1 \quad 1 \quad 0 \quad 0] \quad M_0 \xrightarrow{\sigma} M$$

Monotonicity lemma: example

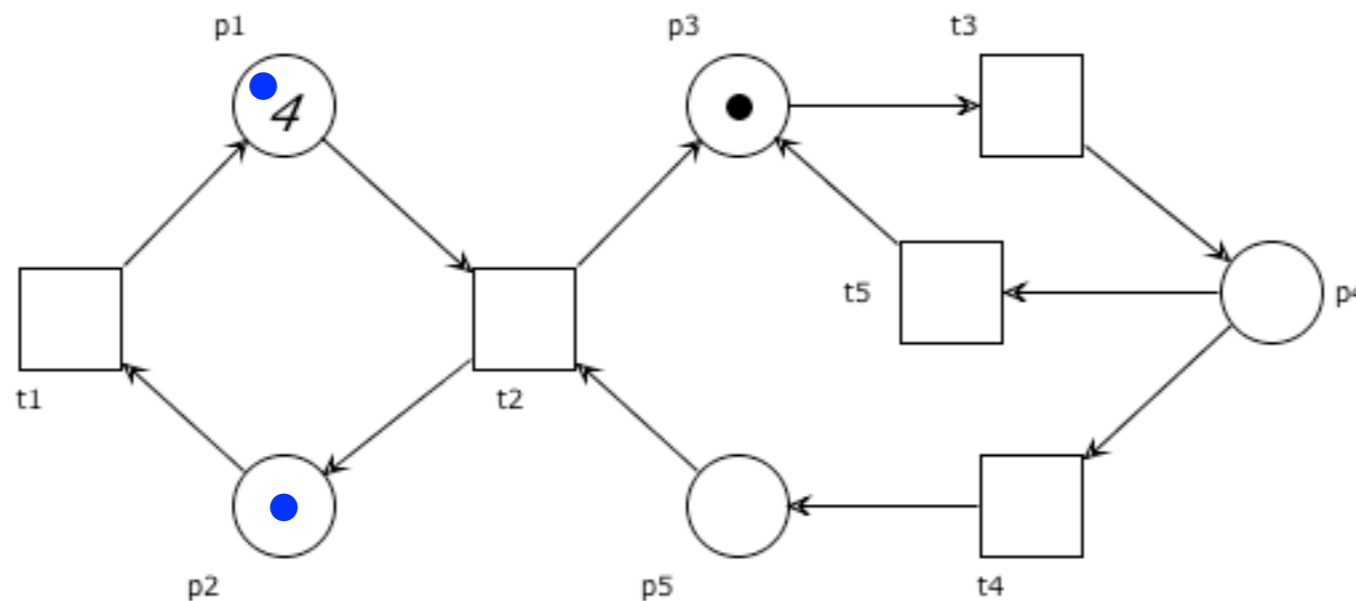

$$M_0 = [4 \quad 0 \quad 1 \quad 0 \quad 0] \quad \sigma = t_3 t_5 t_3 t_4 t_2 \quad \vec{\sigma} = [0 \quad 1 \quad 2 \quad 1 \quad 1]$$

$$M = M_0 + N \cdot \vec{\sigma} = [3 \quad 1 \quad 1 \quad 0 \quad 0] \quad M_0 \xrightarrow{\sigma} M$$

$$L = [1 \quad 1 \quad 0 \quad 0 \quad 0]$$

$$M_0 + L \xrightarrow{\sigma} M + L = [4 \quad 2 \quad 1 \quad 0 \quad 0]$$

Reminder: infinite sequence

Let $\sigma = t_1 t_2 \dots \in T^\omega$ be an infinite sequence of transitions.

We write $M \xrightarrow{\sigma}$ if:

there is an infinite sequence of markings M_1, M_2, \dots

with $M = M_1$ and $M_i \xrightarrow{t_i} M_{i+1}$ for $1 \leq i$

(i.e. $M = M_1 \xrightarrow{t_1} M_2 \xrightarrow{t_2} \dots$)

Reminder: enabledness

Proposition: $M \xrightarrow{\sigma}$ iff $M \xrightarrow{\sigma'}$ for every prefix σ' of σ

Monotonicity lemma (2)

Lemma: If $M \xrightarrow{\sigma}$ then $M + L \xrightarrow{\sigma}$ for any L

Monotonicity lemma (2)

Lemma: If $M \xrightarrow{\sigma}$ then $M + L \xrightarrow{\sigma}$ for any L

If σ is finite then the thesis follows from monotonicity lemma 1

If σ is infinite, then it suffices to prove that:

$M + L \xrightarrow{\sigma'}$ for any finite prefix σ' of σ

Take any such prefix σ' . Then, $M \xrightarrow{\sigma'}$ (because $M \xrightarrow{\sigma}$)

By the marking equation lemma, $M \xrightarrow{\sigma'} M + \mathbf{N} \cdot \vec{\sigma}'$.

By monotonicity lemma 1, $M + L \xrightarrow{\sigma'} M + \mathbf{N} \cdot \vec{\sigma}' + L$

Hence $M + L \xrightarrow{\sigma'}$

Monotonicity lemma, intuitively

If some activities can be done with less (resources),
then the same activities can be done with more (resources)

If we perform activities with more resources than needed,
then the additional resources are preserved

Corollary

Corollary: If $M \xrightarrow{\sigma} M'$ with $M \subseteq M'$ then $M \xrightarrow{\sigma\sigma\cdots}$

Corollary

Corollary: If $M \xrightarrow{\sigma} M'$ with $M \subseteq M'$ then $M \xrightarrow{\sigma\sigma\cdots}$

We need to show that every prefix of $\sigma\sigma\cdots$ is enabled at M .
Any such prefix take the form $\sigma'' = \underbrace{\sigma \cdots \sigma}_n \sigma'$ with σ' a prefix of σ .

We prove that $M \xrightarrow{\sigma''}$ by induction on n :

base: $\sigma'' = \sigma'$ is a prefix of σ and $M \xrightarrow{\sigma'}$ by Enabledness Prop.

induction: We assume that $M \xrightarrow{\sigma''}$ and prove that $M \xrightarrow{\sigma\sigma''}$.

Let $L = M' - M$. By Monotonicity Lemma $M + L \xrightarrow{\sigma''}$.

Thus $M \xrightarrow{\sigma} M + L \xrightarrow{\sigma''}$ and $M \xrightarrow{\sigma\sigma''}$.

Boundedness Lemma

Lemma: If a system is bounded and $M \in [M_0)$ with $M \supseteq M_0$, then $M = M_0$.

Boundedness Lemma

Lemma: If a system is bounded and $M \in [M_0\rangle$ with $M \supseteq M_0$, then $M = M_0$.

Let $M_0 \xrightarrow{\sigma} M$.

By $M \supseteq M_0$, there exists a marking L with $M = M_0 + L$.

Let $M_k = M_0 + k \cdot L$ for every $k \in \mathbb{N}$.

By the Monotonicity Lemma, we have:

$$M_0 \xrightarrow{\sigma} M_1 \xrightarrow{\sigma} M_2 \cdots$$

i.e., $M_k \in [M_0\rangle$ for any $k \in \mathbb{N}$.

Since the system is bounded, it must be $L = \emptyset$.

Boundedness lemma: consequences

If we show that a marking M is reachable with

$$M \supset M_0$$

then the system is not bounded

Repetition Lemma

Lemma: If $M \xrightarrow{\sigma} M'$ and $M \xrightarrow{\sigma\sigma\cdots}$, then $M \subseteq M'$.

Repetition Lemma

Lemma: If $M \xrightarrow{\sigma} M'$ and $M \xrightarrow{\sigma\sigma\cdots}$, then $M \subseteq M'$.

We proceed by contradiction.

Suppose $M \not\subseteq M'$, i.e., there exist $k > 0, p \in P$ such that $M'(p) = M(p) - k$.

By the Marking Equation Lemma we have $M' = M + \mathbf{N} \cdot \vec{\sigma}$.

Therefore $(\mathbf{N} \cdot \vec{\sigma})(p) = -k$.

Let $n = M(p) + 1$ and $\sigma' = \underbrace{\sigma \cdots \sigma}_n$.

By hypothesis we have $M \xrightarrow{\sigma'} M''$,

and by the Marking Equation Lemma $M''(p) = M(p) - nk < 0$, which is absurd.

Repetition Lemma: consequences

If σ can be fired any number of times
it means that σ produces more resources than it consumes
(or as many as it consumes)

Exercises

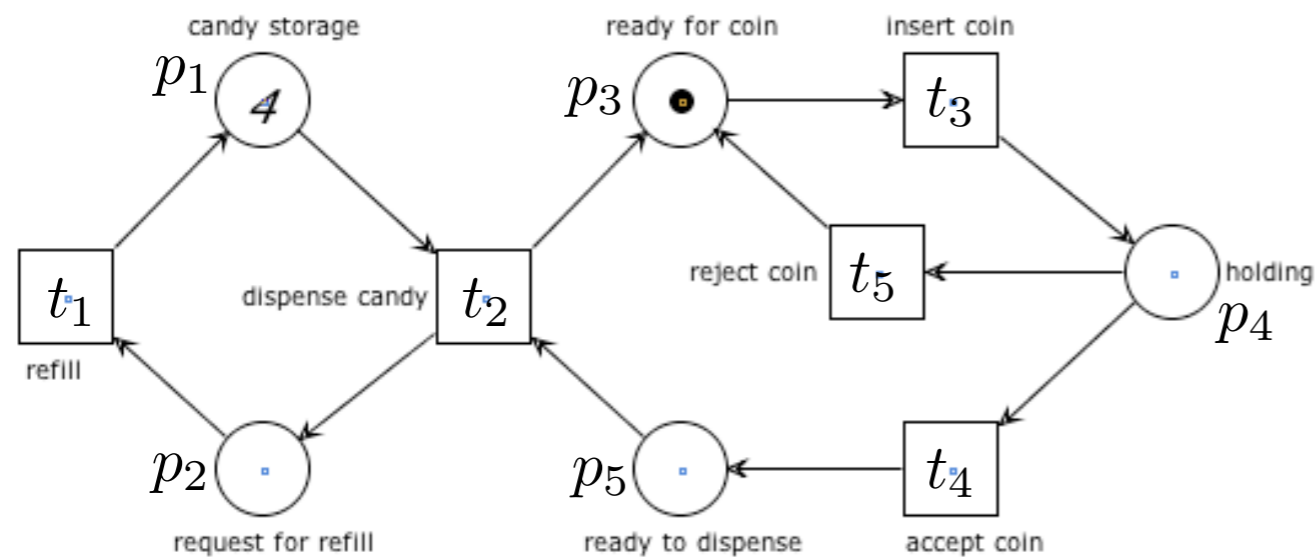

- Compute the Parikh vector of $\sigma = t_3 t_4 t_2 t_3 t_5 t_3 t_4 t_1 t_2 t_1 t_3 t_5 t_2$
- Show that σ is not enabled at $M_0 = 4p_1 + p_3$
(*Hint: Exploit the Marking Equation Lemma*)
- Let $\sigma' = t_3 t_4 t_2 t_1$. Prove that $M_0 \xrightarrow{\sigma' \sigma' \dots}$
(*Hint: Exploit the Corollary of Monotonicity Lemma*)