

Business Processes Modelling

MPB (6 cfu, 295AA)

Roberto Bruni

<http://www.di.unipi.it/~bruni>

13 - Workflow nets



Object

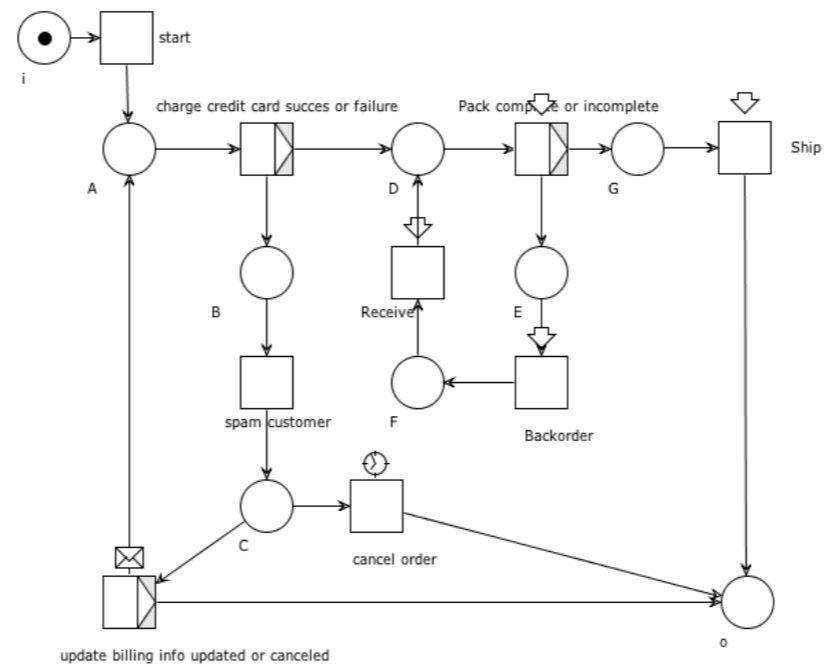

We study some special kind of Petri nets,
that are suitable models of workflows

There are many, many
variants of Petri nets

Example: Coloured nets (also called High-Level)

A **coloured net** is a Petri net whose tokens can carry data and whose transitions can check data (see exact definition in Weske's book)

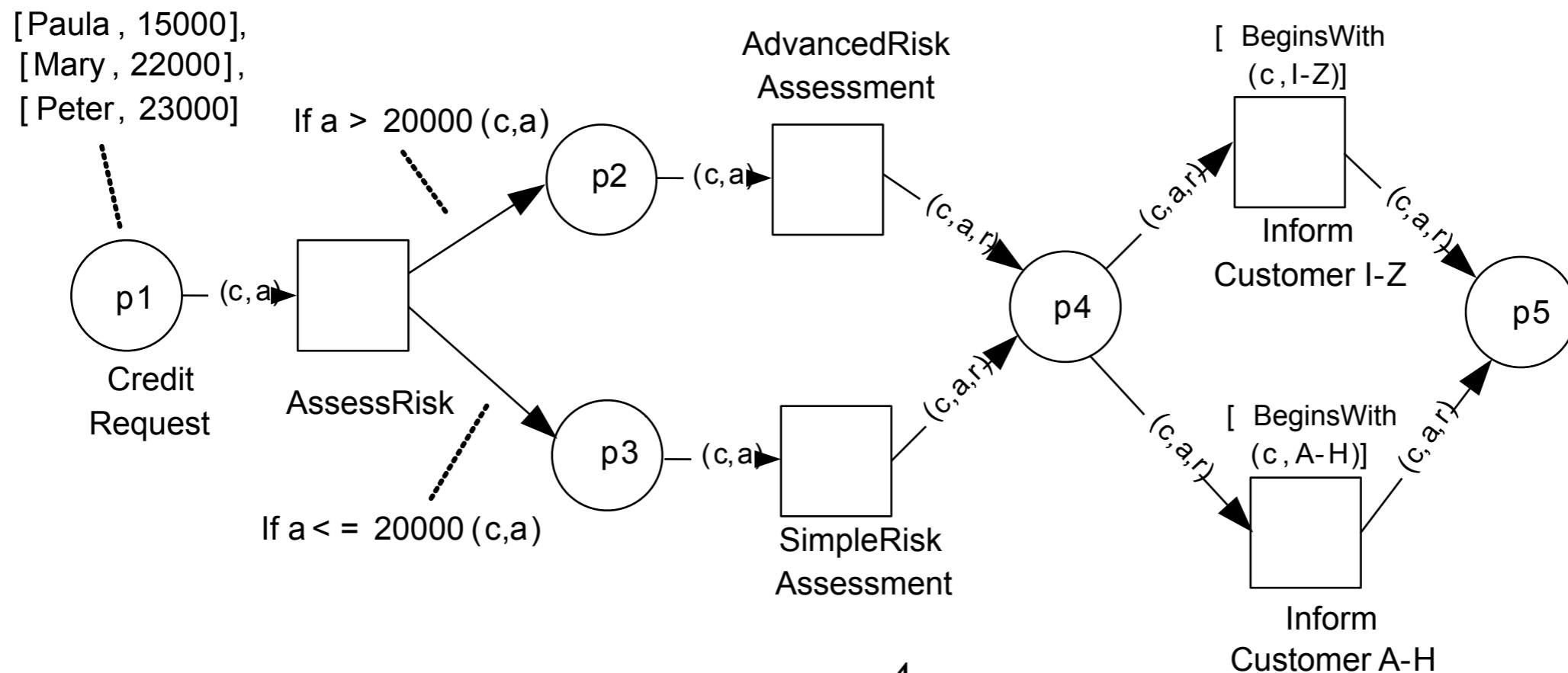

Workflow nets

Workflow nets features

Tailored to the representation of business processes

Formal (unambiguous) semantics

Structural restrictions

Decorated graphical representation

Workflow net: idea

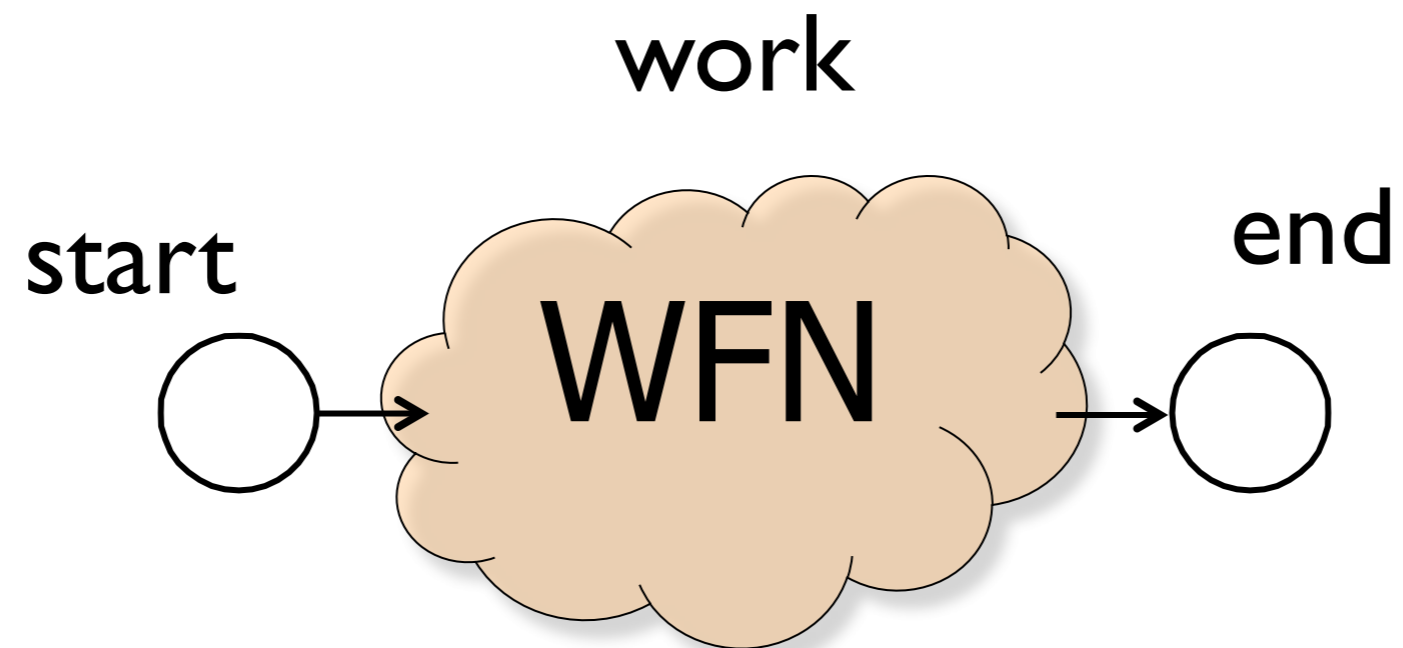

Workflow net

Definition:

A Petri net (P, T, F) is called **workflow net** if:

1. there is a distinguished *initial place* $i \in P$ with $\bullet i = \emptyset$
2. there is a distinguished *final place* $o \in P$ with $o \bullet = \emptyset$
3. every other place and transition belongs to a path from i to o

Basic properties

Lemma: In a workflow net there is a **unique** node with no incoming arc

Proof:

Let i be the initial place and o the final one

Suppose there is another node v with no incoming arc

node v must appear in a path from i to o

since $\bullet v = \emptyset$, v must be the first node of the path

thus $v = i$

Basic properties

Lemma: In a workflow net there is a **unique** node with no outgoing arc

(the proof is analogous to the previous one)

Workflow net: Rationale

1. a token in i represents a process instance not yet started
2. a token in o represents a finished case
3. each place and each transition can participate in a case

Definition:

A Petri net (P, T, F) is called **workflow net** if:

1. there is a distinguished *initial place* $i \in P$ with $\bullet i = \emptyset$
2. there is a distinguished *final place* $o \in P$ with $o \bullet = \emptyset$
3. every other place and transition belongs to a path from i to o



WF net: Example

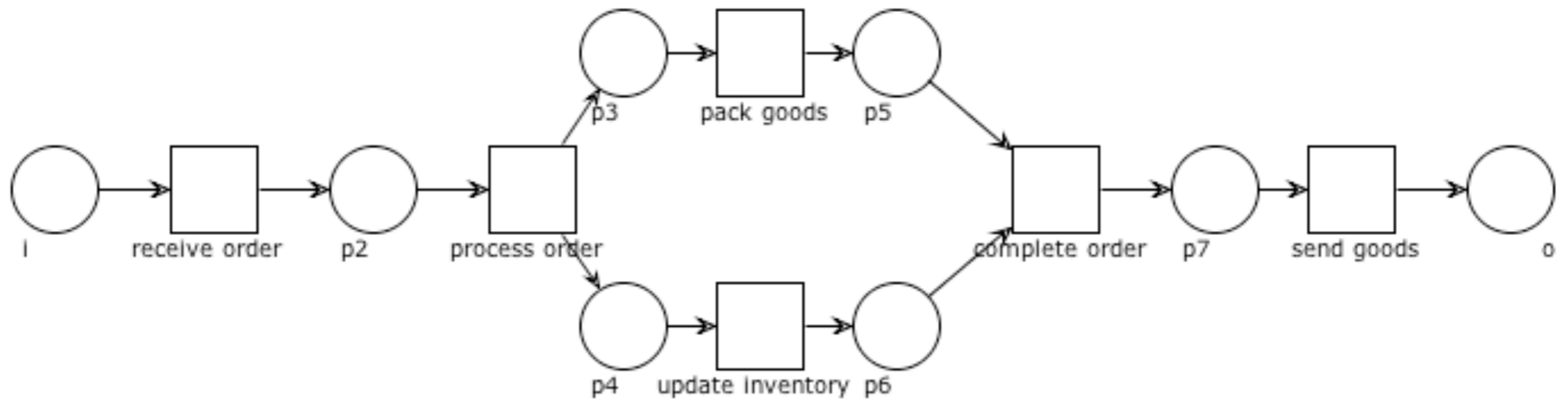

Question time: WF net?

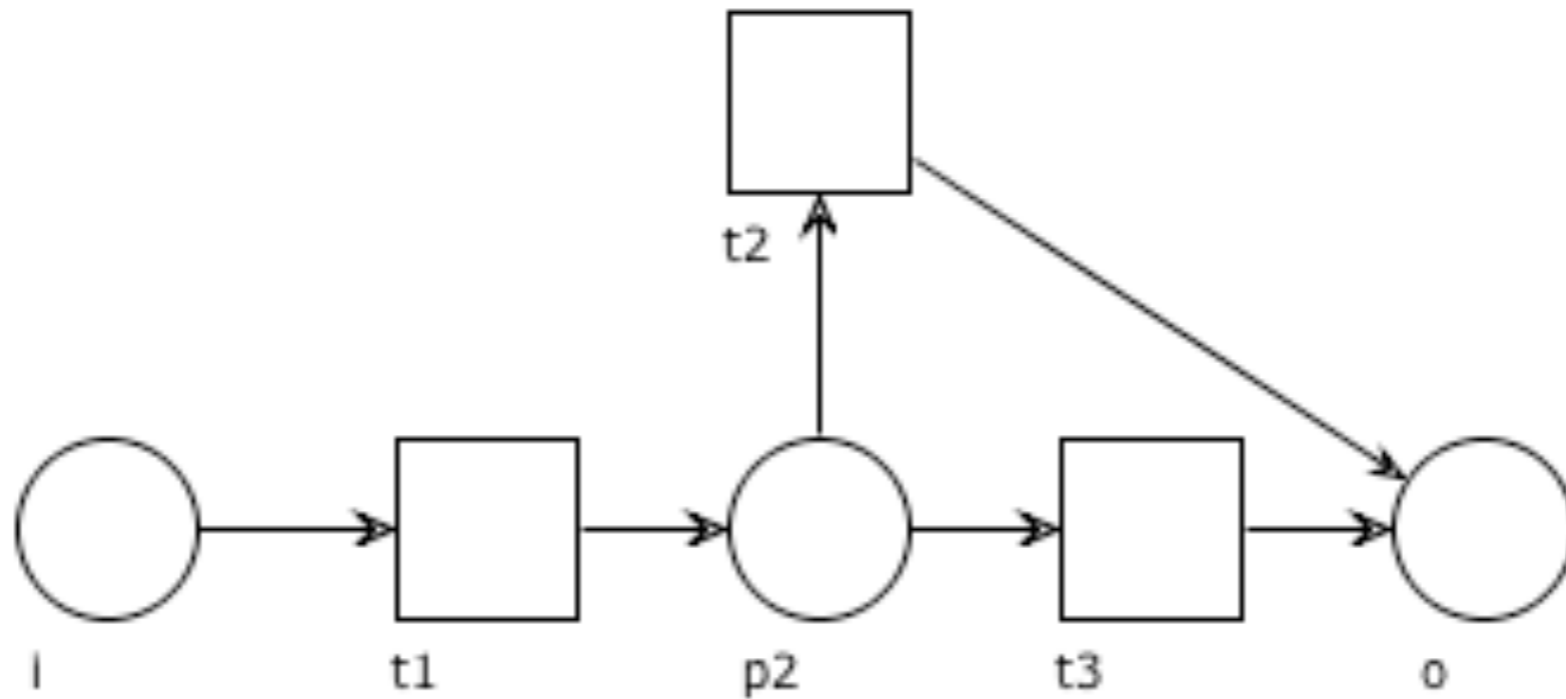

Question time: WF net?

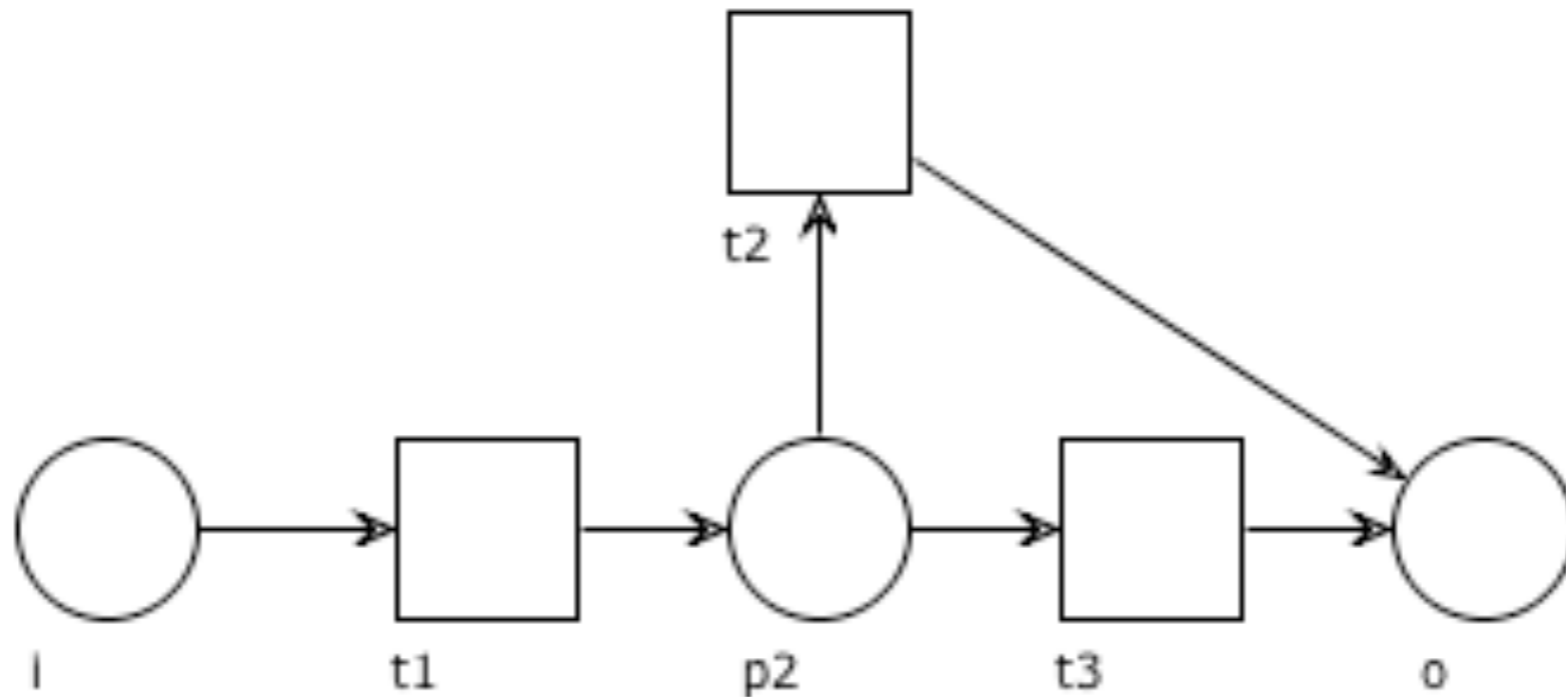

Yes

Question time: WF net?

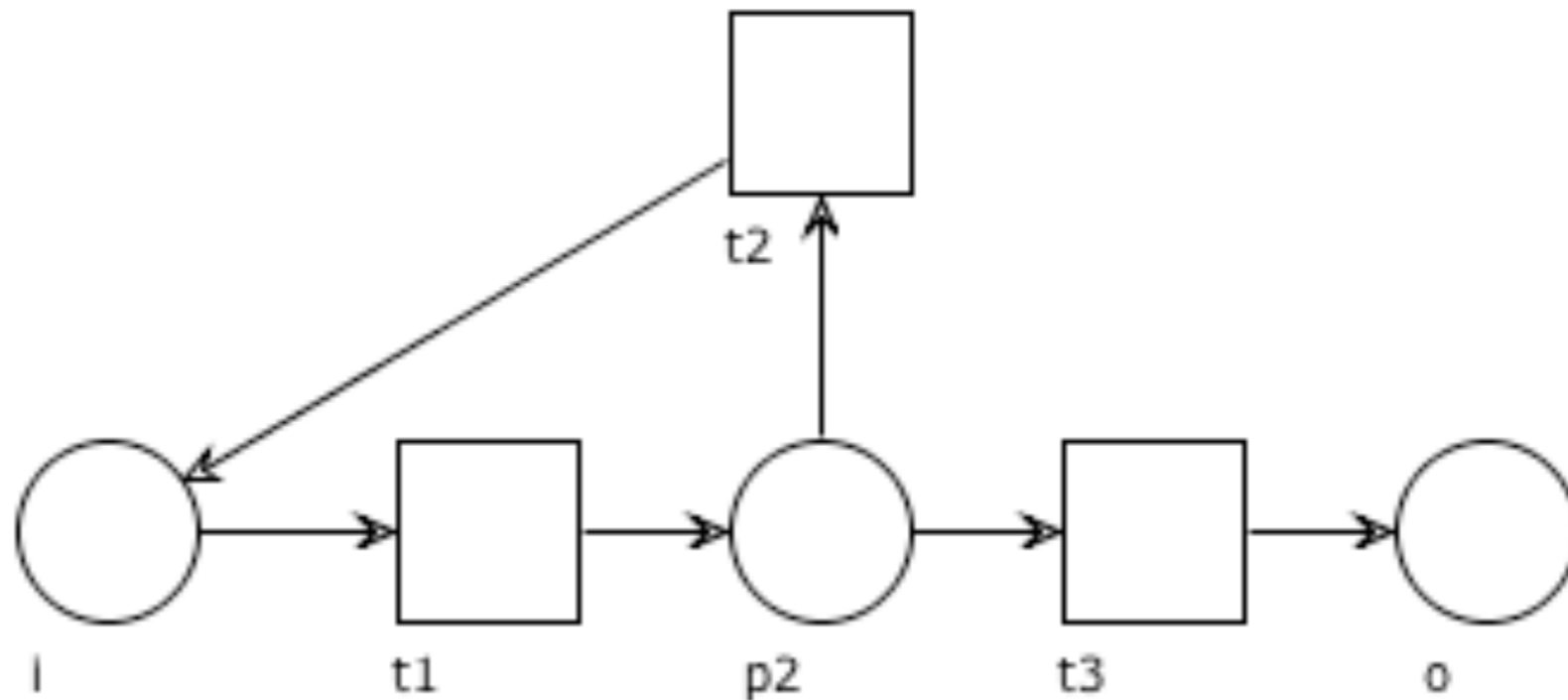

Question time: WF net?

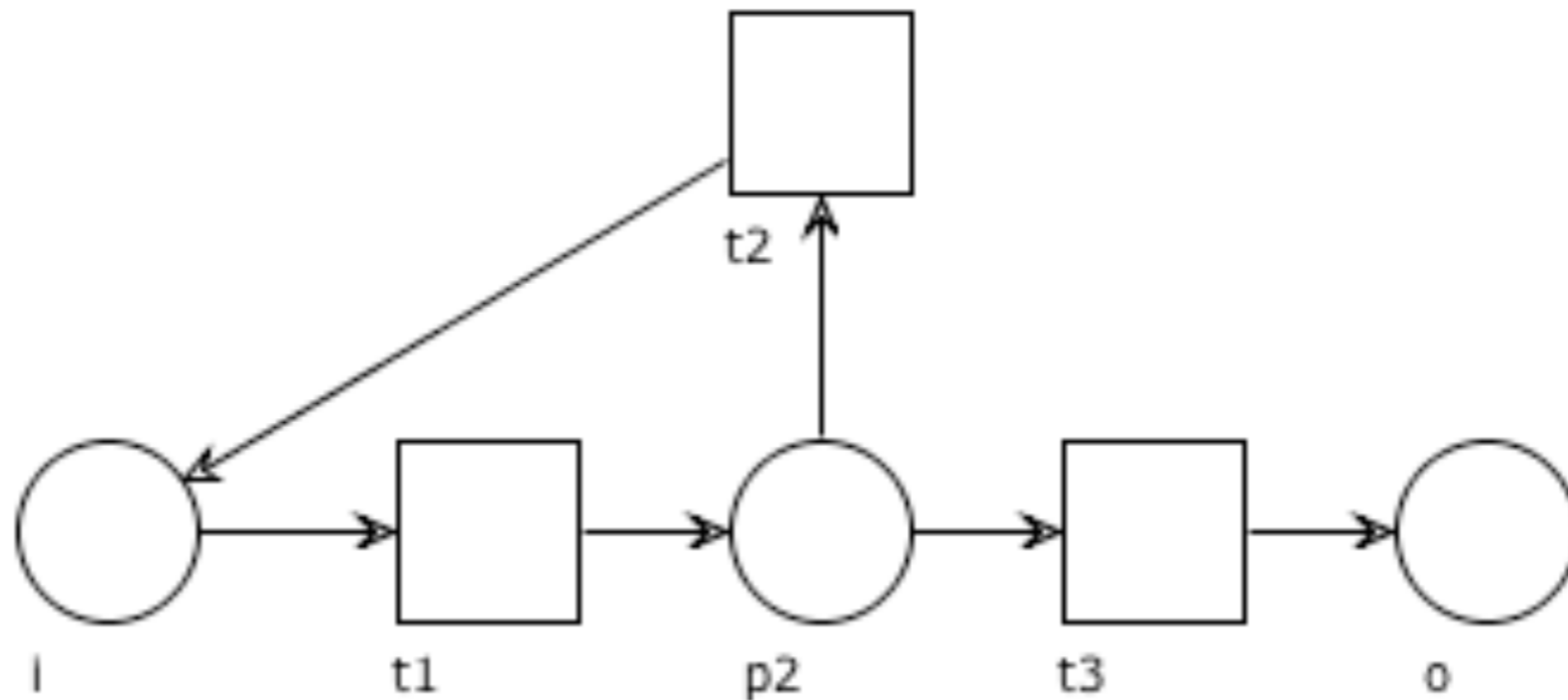

No
(no initial place)

Question time: WF net?

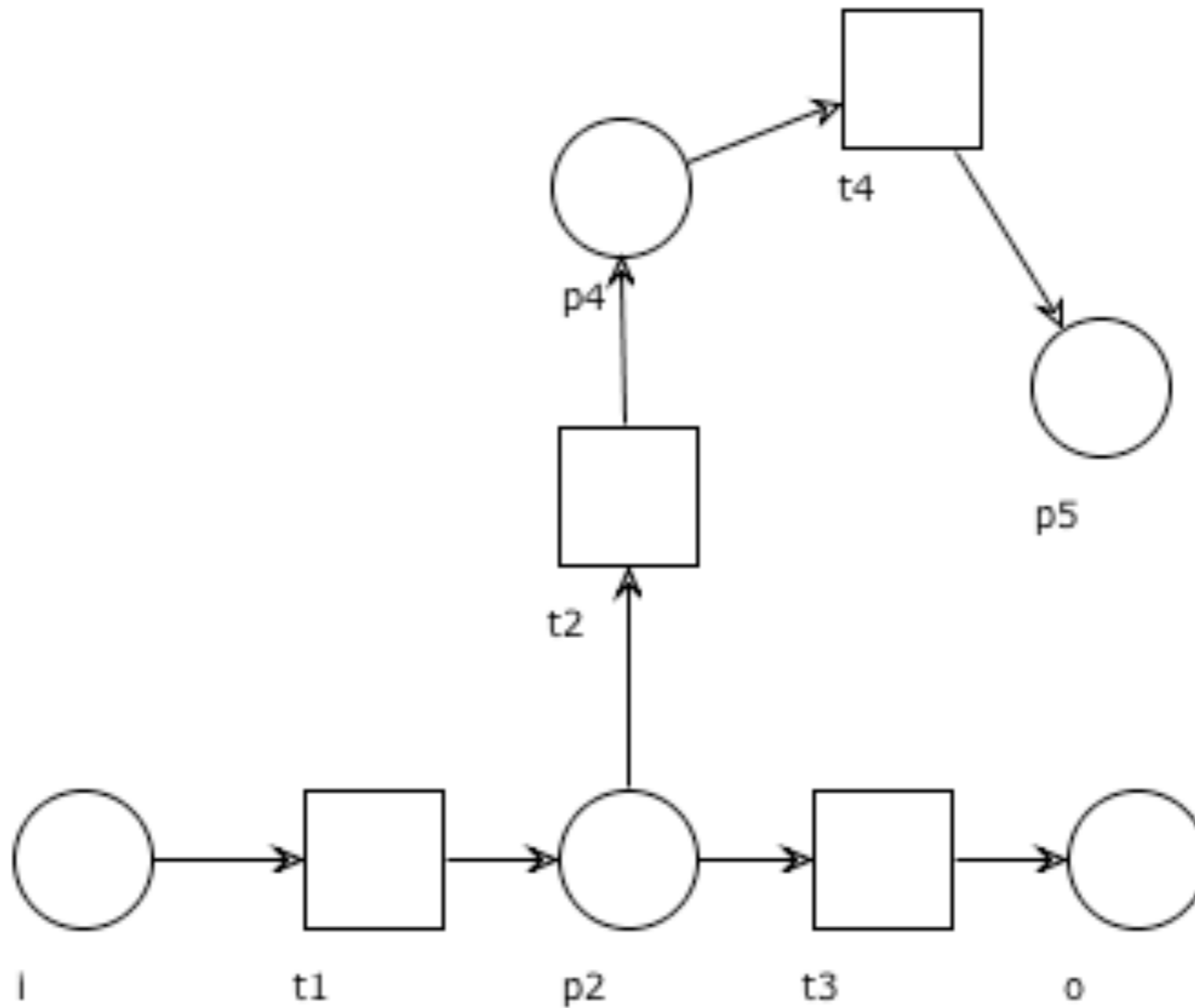

Question time: WF net?

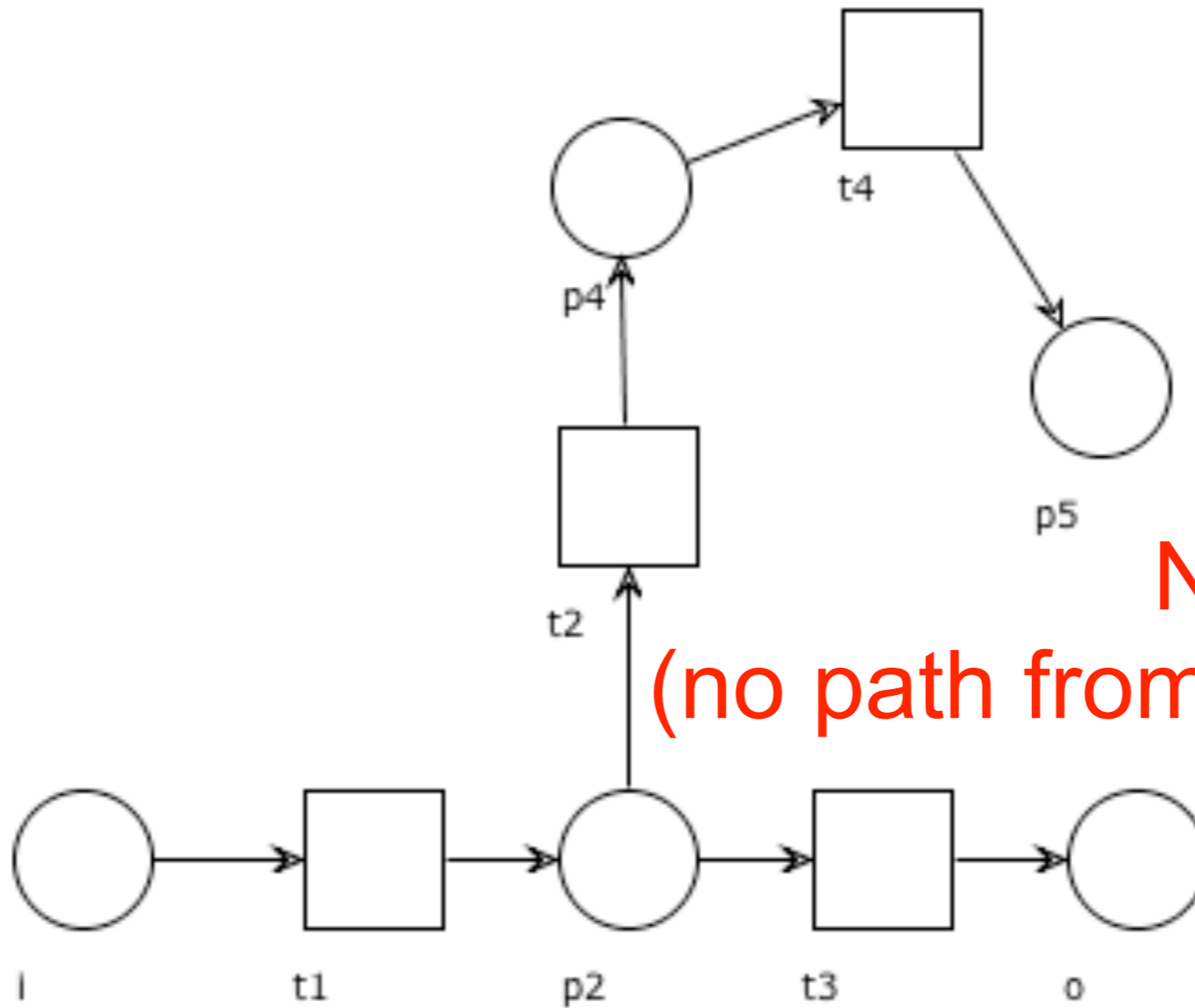

No
(no path from i to o with t2)

Question time: WF net?

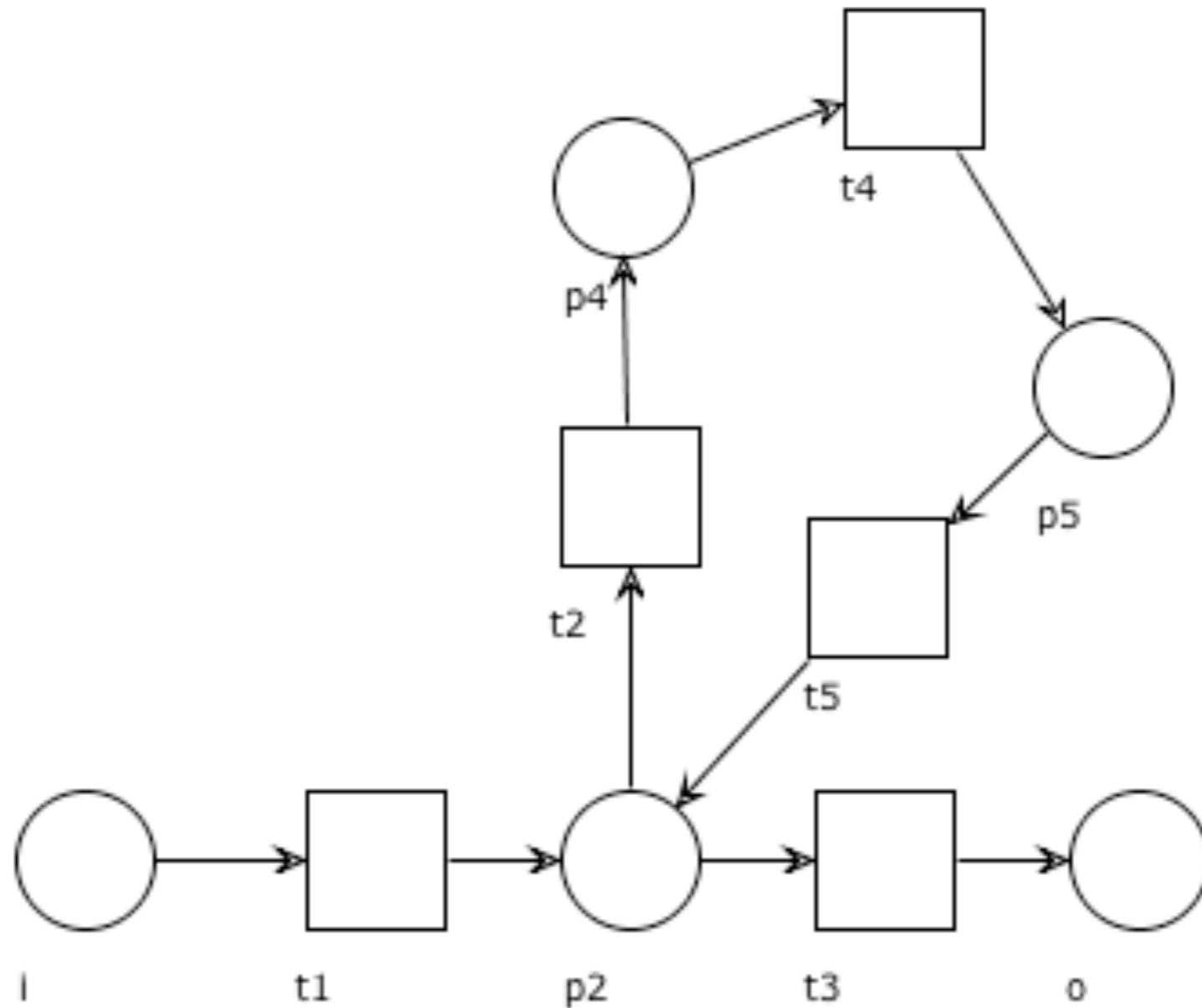

Question time: WF net?

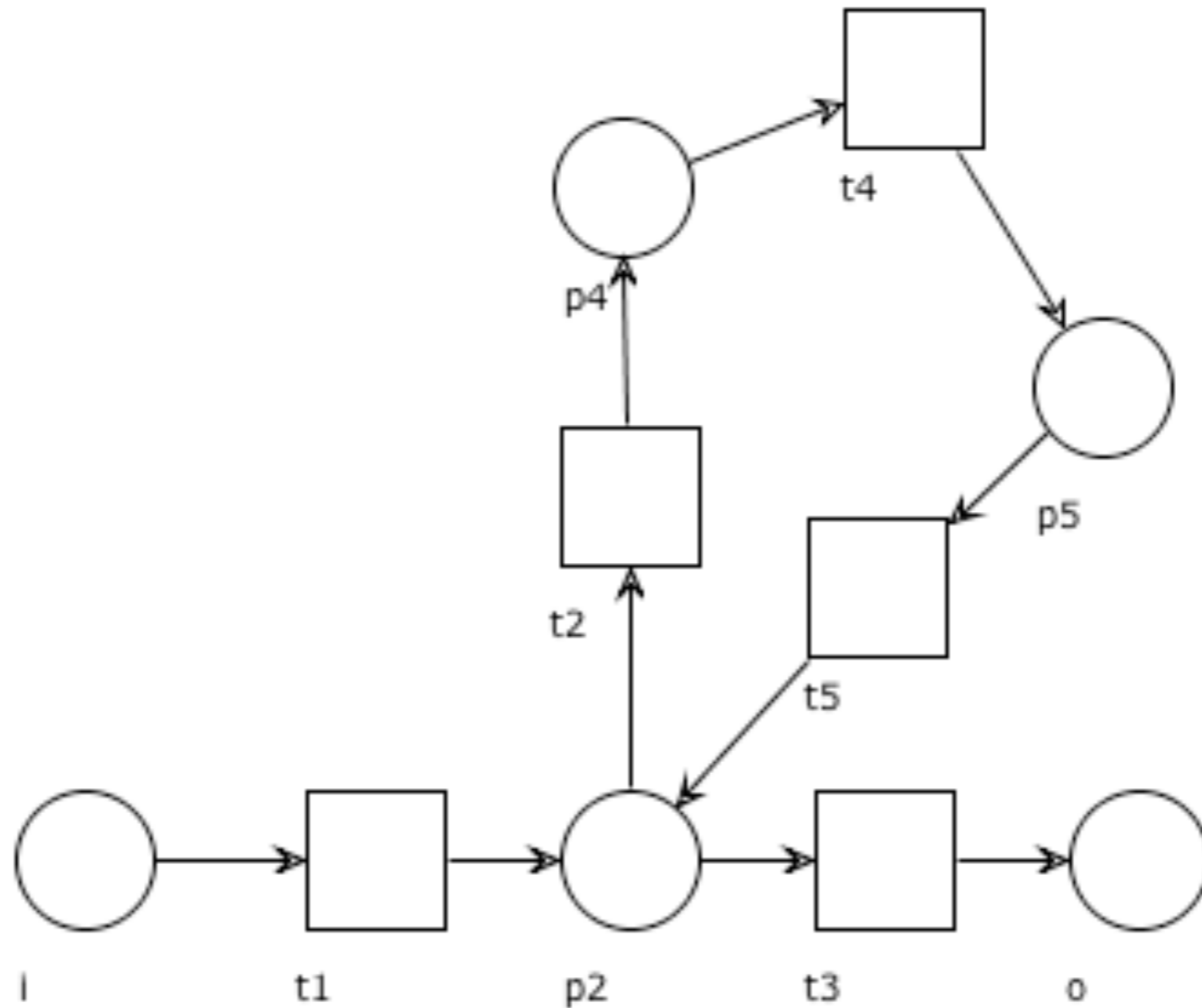

Yes

Question time: WF net?

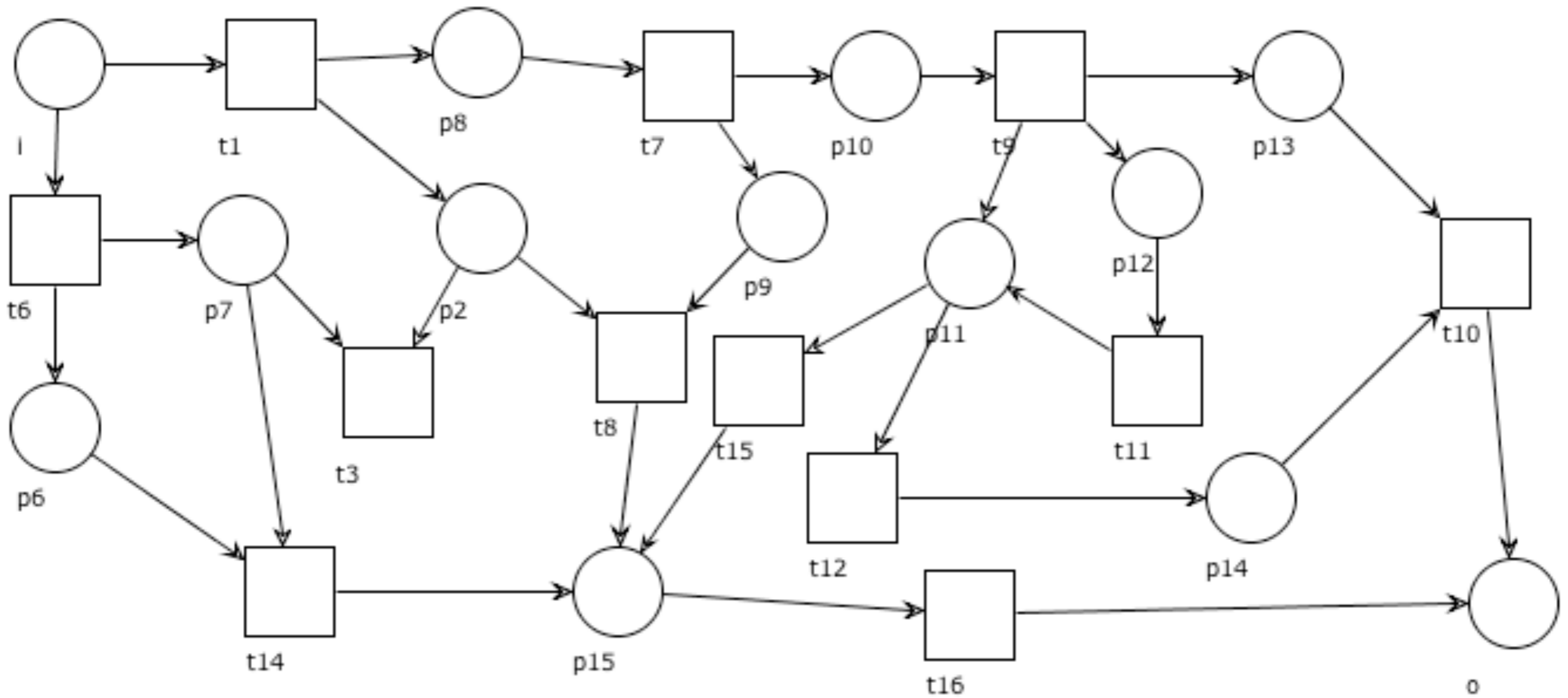

Question time: WF net?

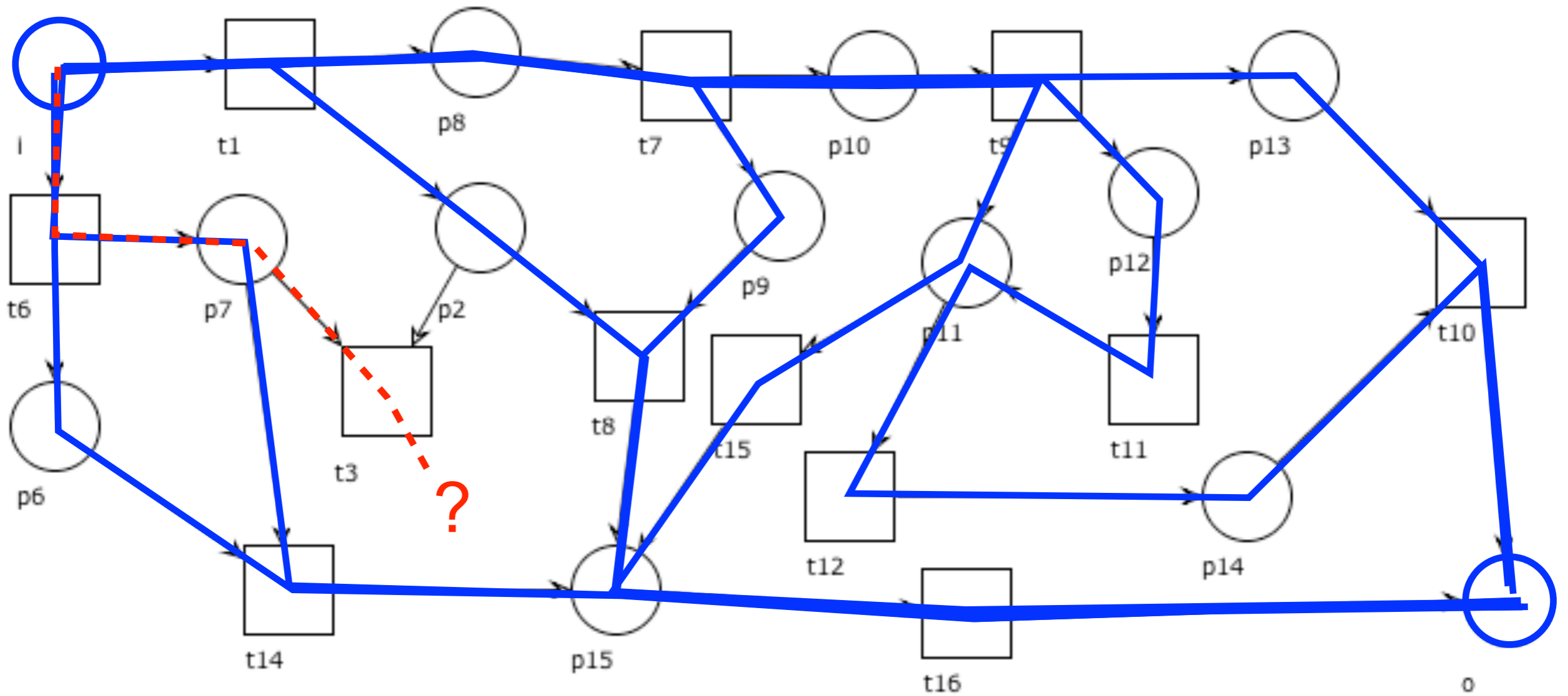

Question time: WF net?

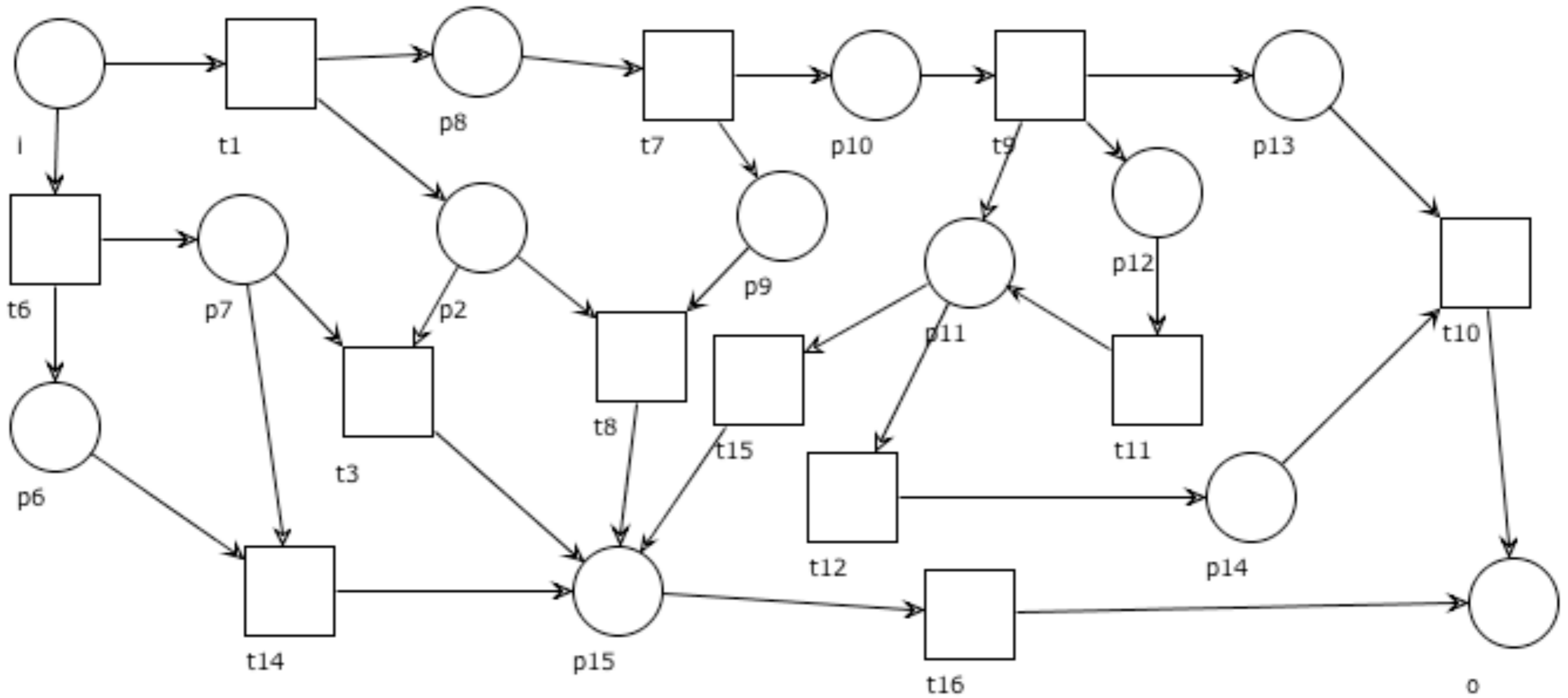

Question time: WF net?

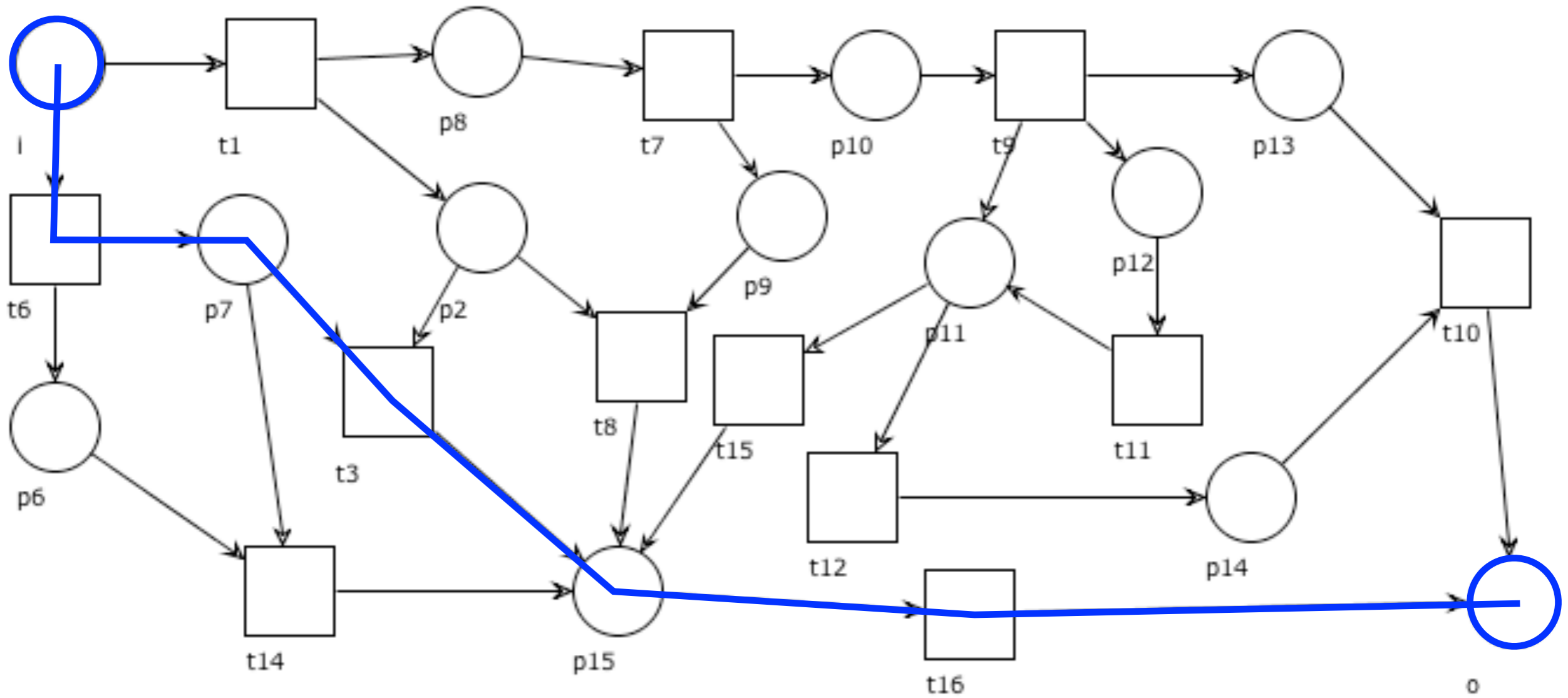

Yes

Syntax sugar (denotations)

<http://woped.dhbw-karlsruhe.de/woped/>

WoPeD



Workflow Petri Net Designer

Download WoPeD at sourceforge!



Transition properties

Identification

Name: ID#:

Branching

<input checked="" type="radio"/> None	<input type="checkbox"/>	<input type="radio"/> AND-split	<input type="checkbox"/>	<input type="radio"/> AND-join	<input type="checkbox"/>
		<input type="radio"/> XOR-split	<input type="checkbox"/>	<input type="radio"/> XOR-join	<input type="checkbox"/>
		<input type="radio"/> XOR-join-split	<input type="checkbox"/>	<input type="radio"/> AND-join-split	<input type="checkbox"/>
		<input type="radio"/> AND-join-XOR-split	<input type="checkbox"/>	<input type="radio"/> XOR-join-AND-split	<input type="checkbox"/>

Syntax sugar: split

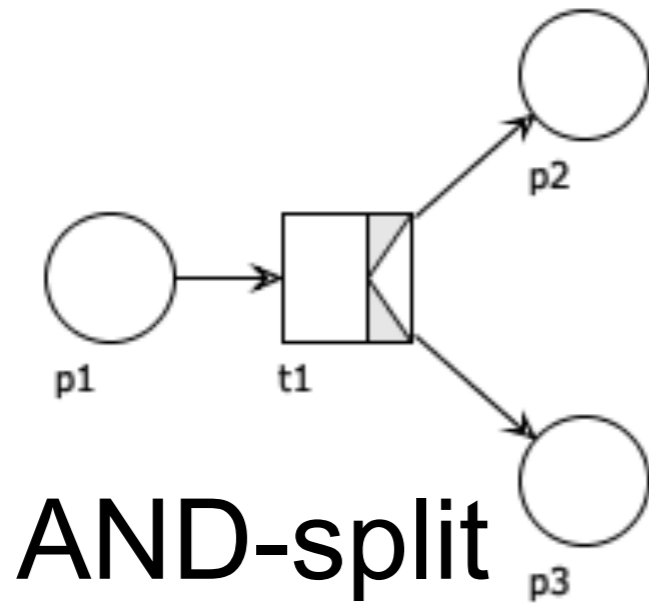

stands for

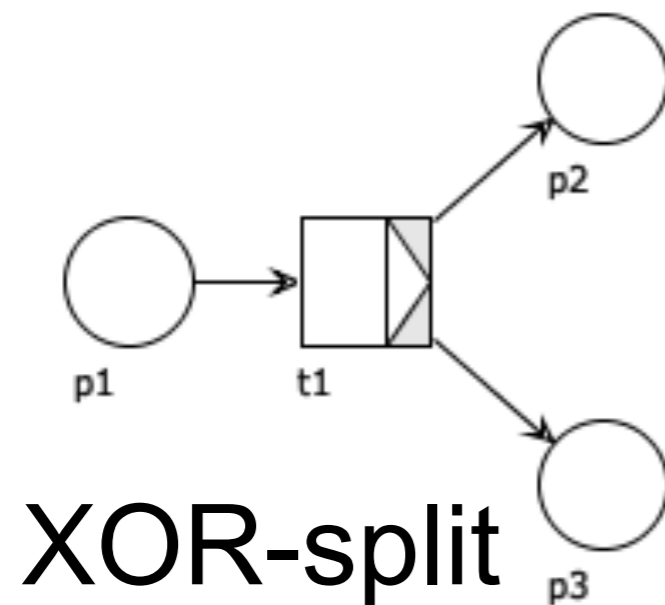
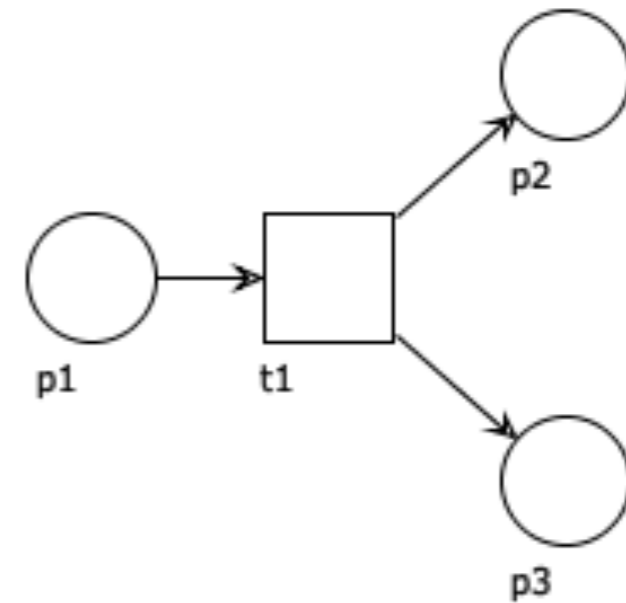

stands for

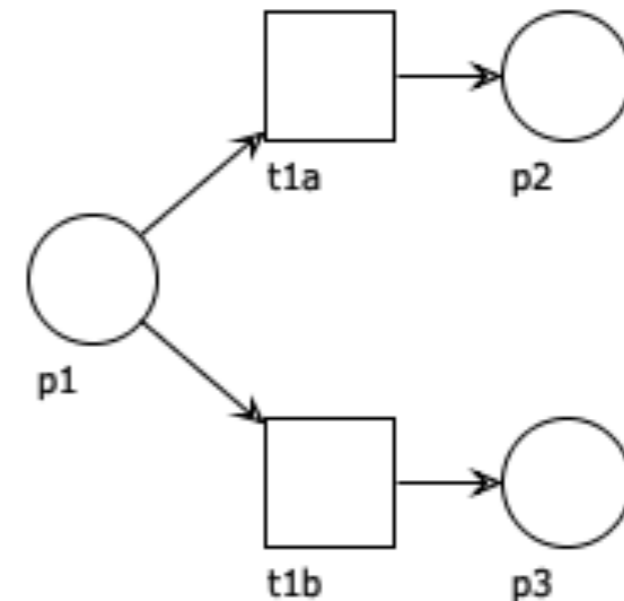

Syntax sugar: join

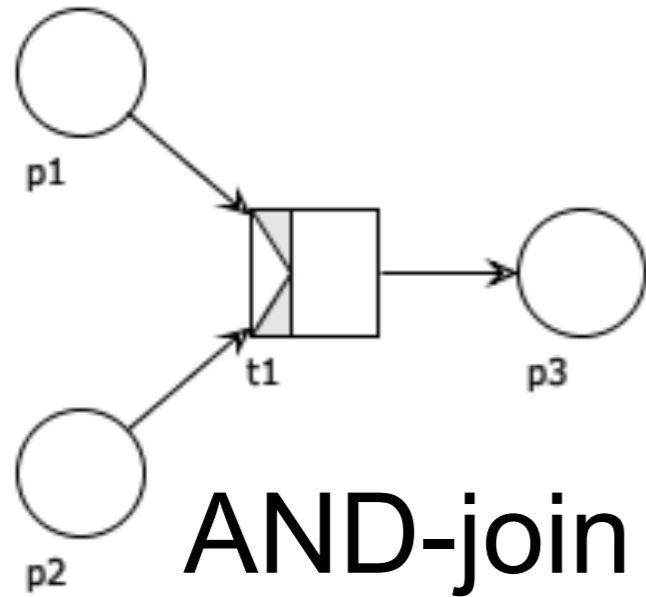

stands for

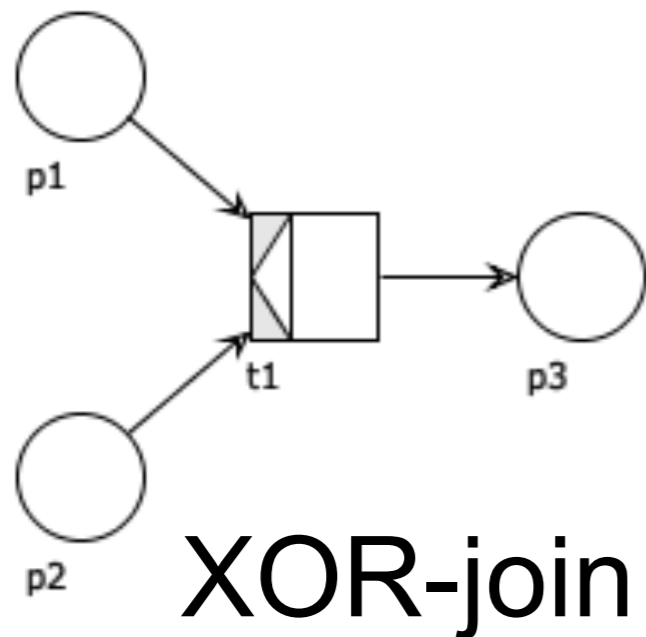
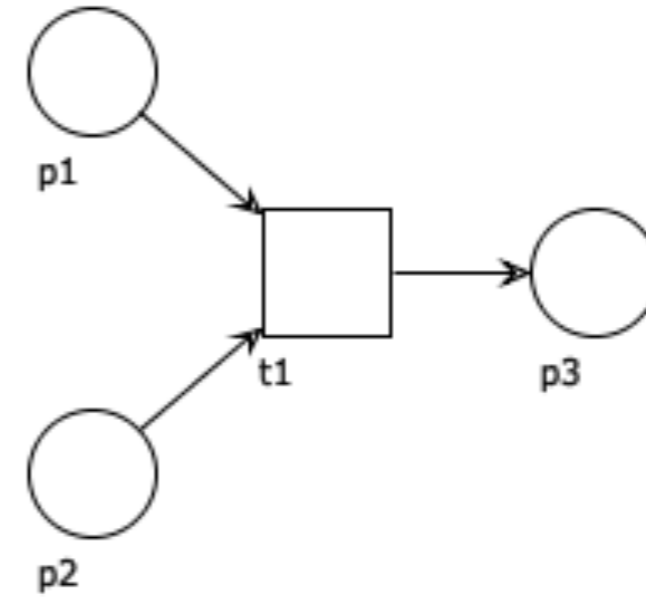

stands for

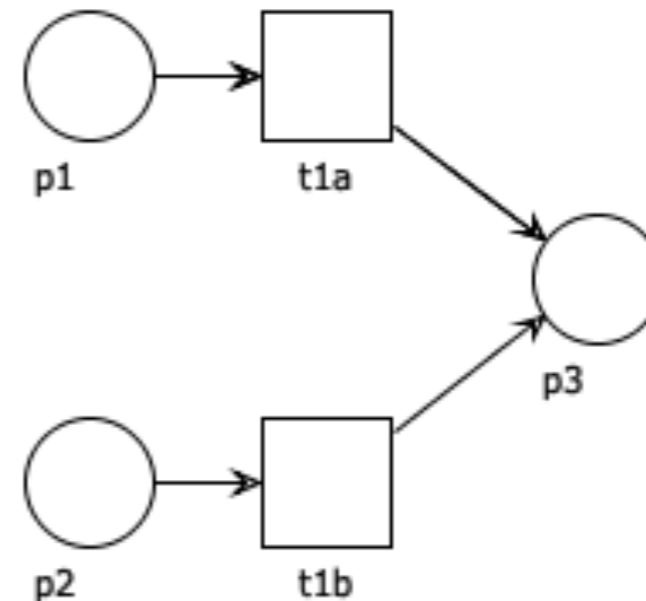

Syntax sugar: any combination is also possible

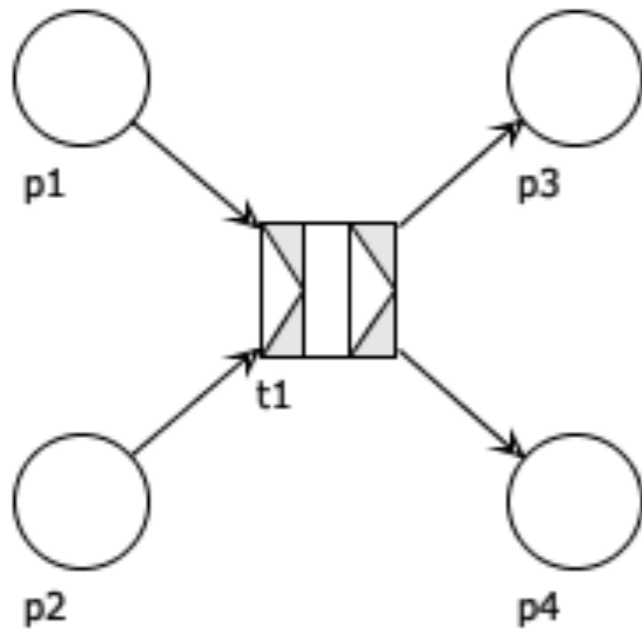

stands for

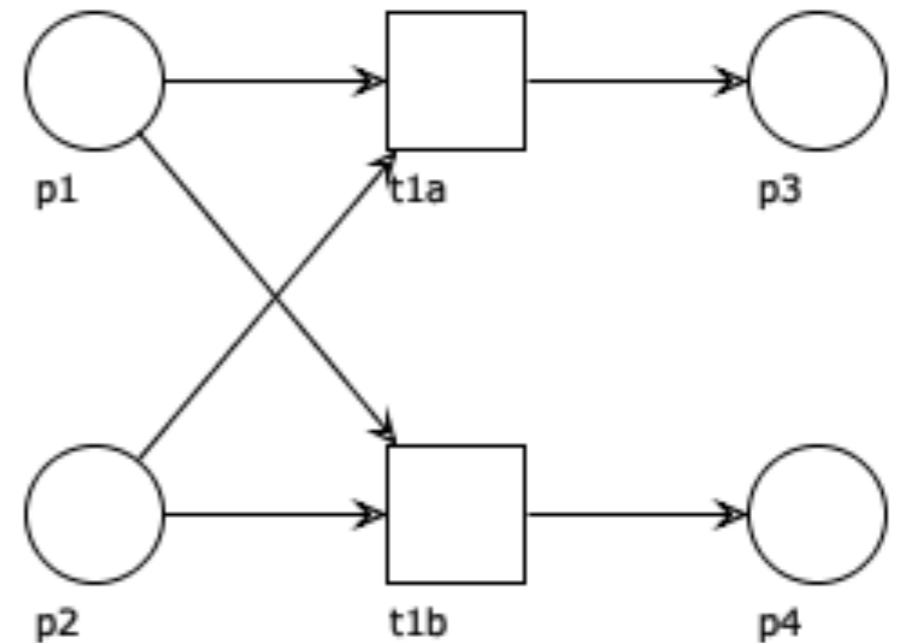
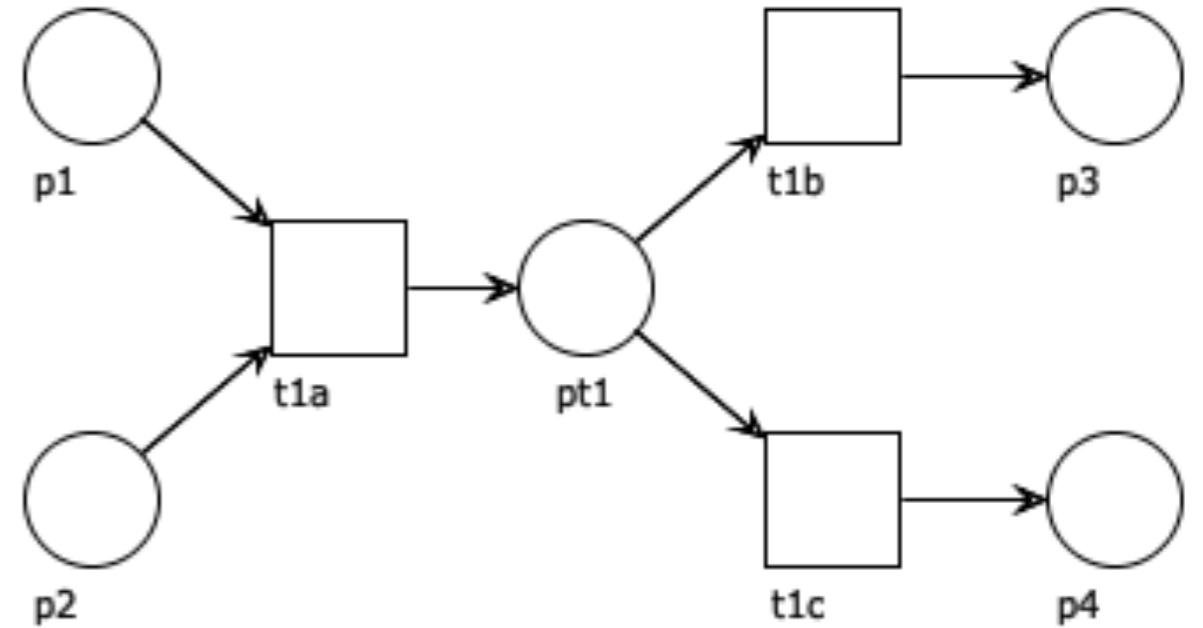

Syntax sugar: any combination is also possible

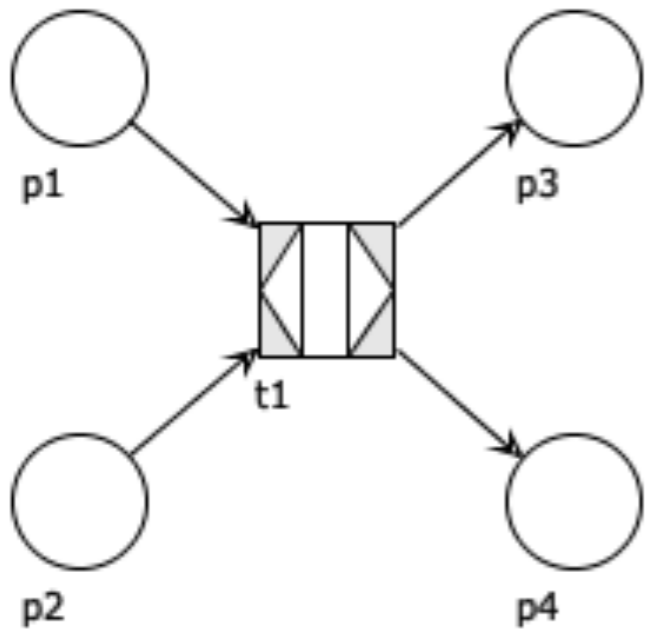

stands for

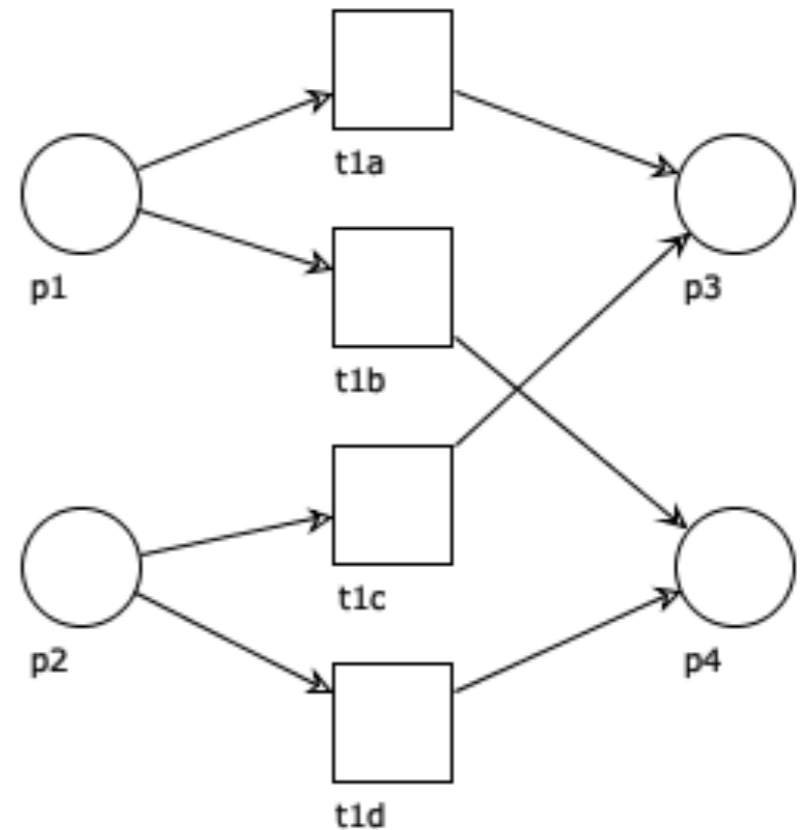
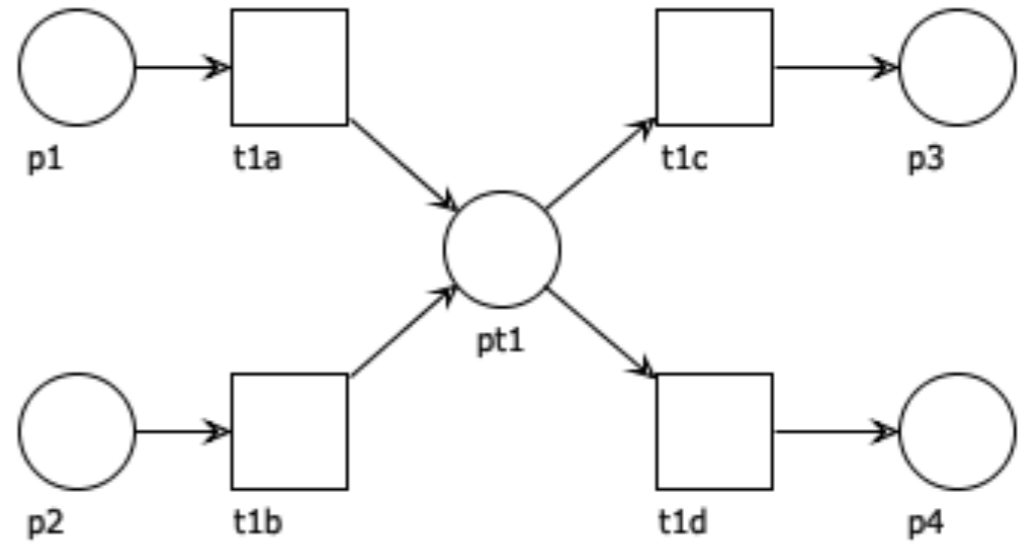

Syntax sugar: a personal note

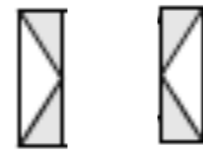
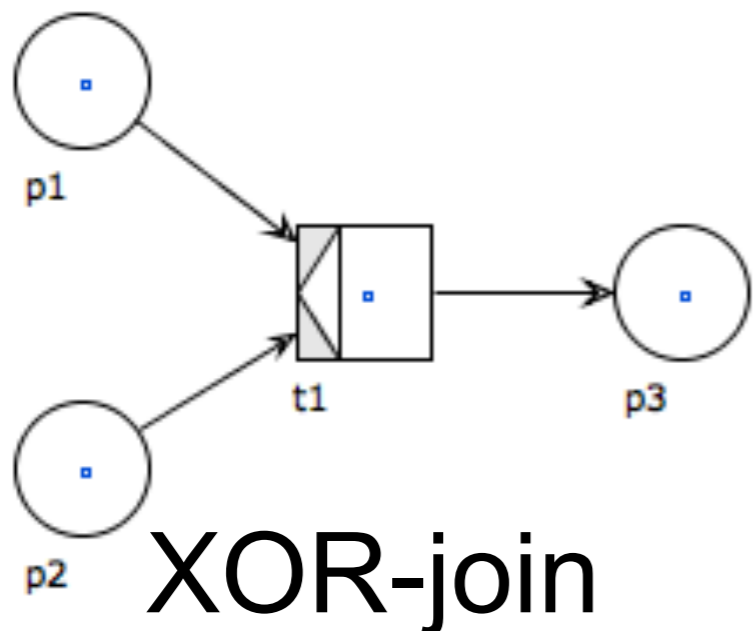
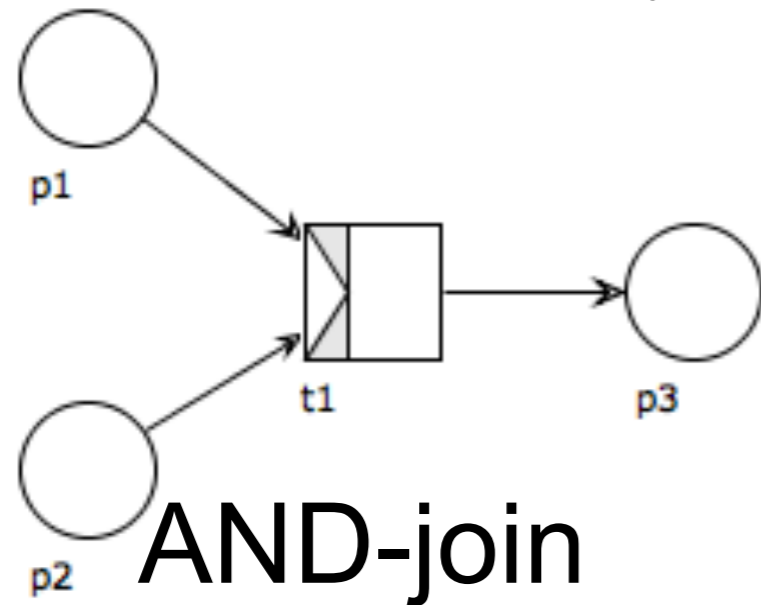

Chosen decorations
are too similar!

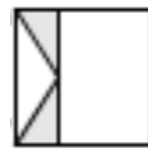

Different meanings
if differently placed!

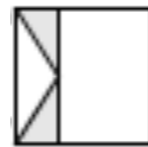
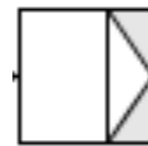

Unnecessary for AND
(redundant)!



Syntax sugar: a personal note

Why there?

Because of gateways

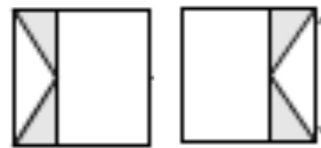

Syntax sugar: a personal note

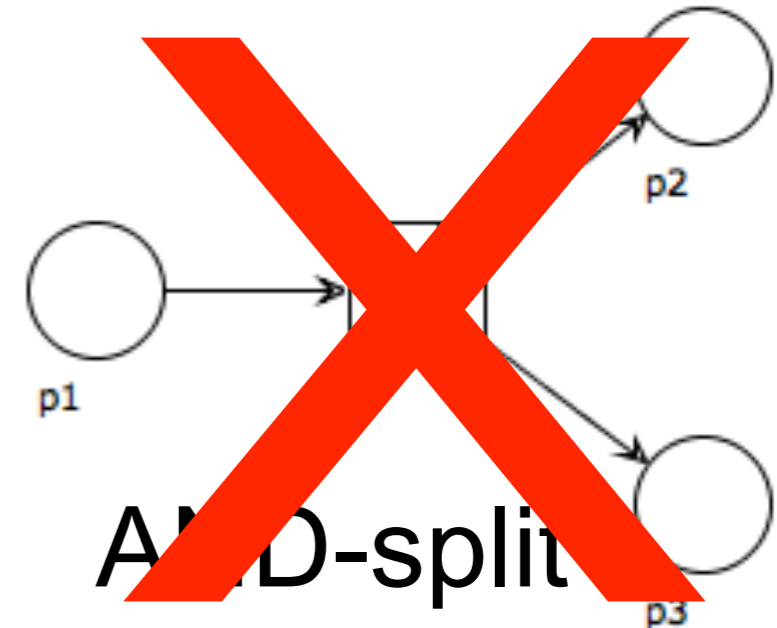
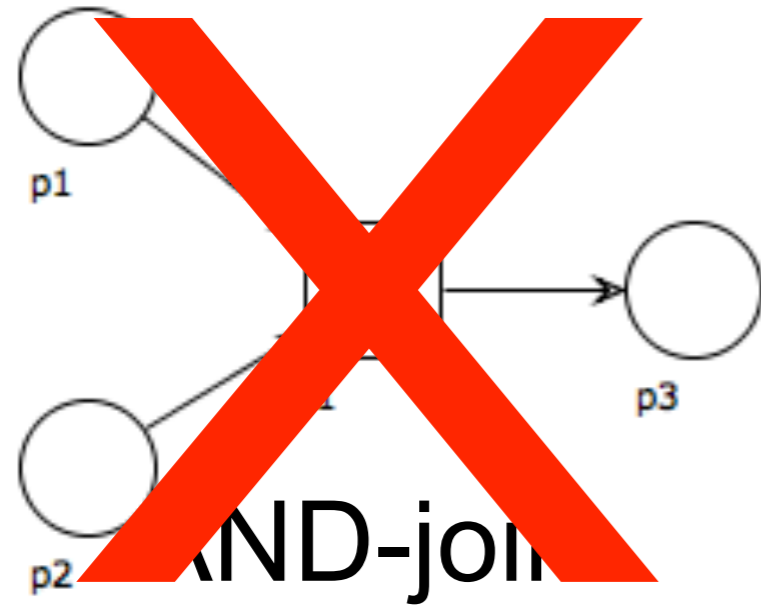

Let us avoid any source of confusion!

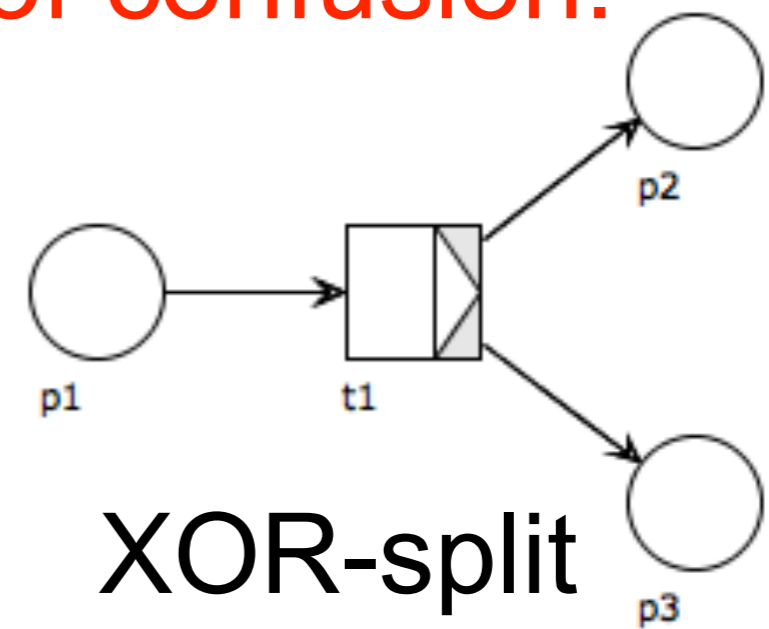
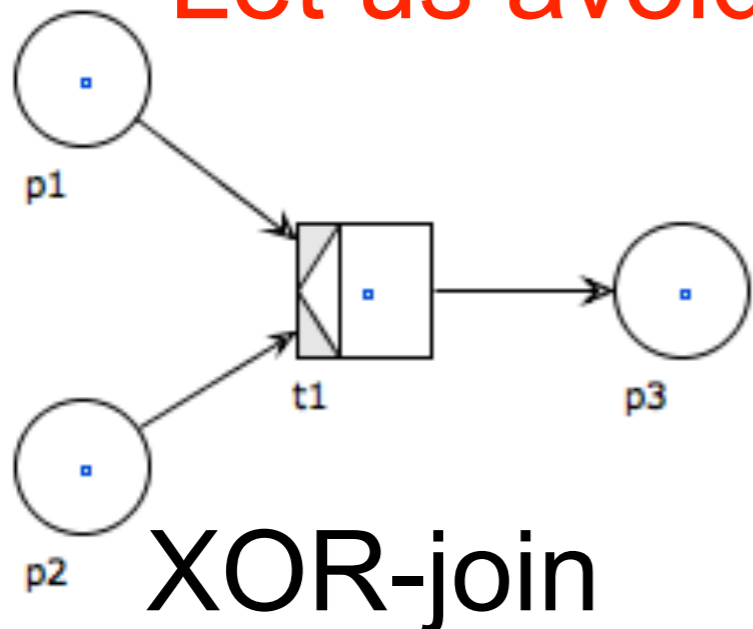

Subprocesses

<http://woped.dhbw-karlsruhe.de/woped/>

WoPeD



Workflow Petri Net Designer

Download WoPeD at sourceforge!

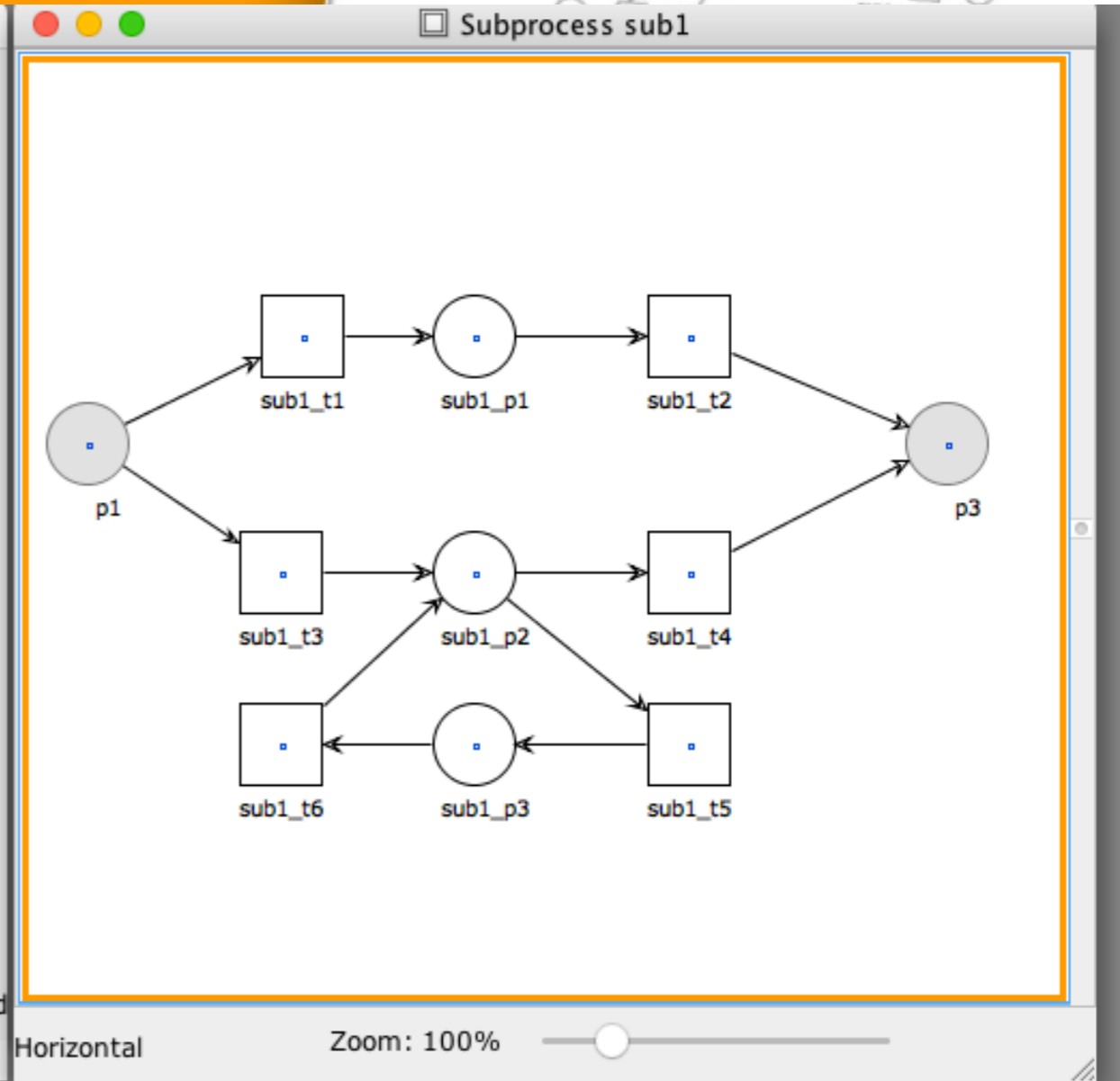
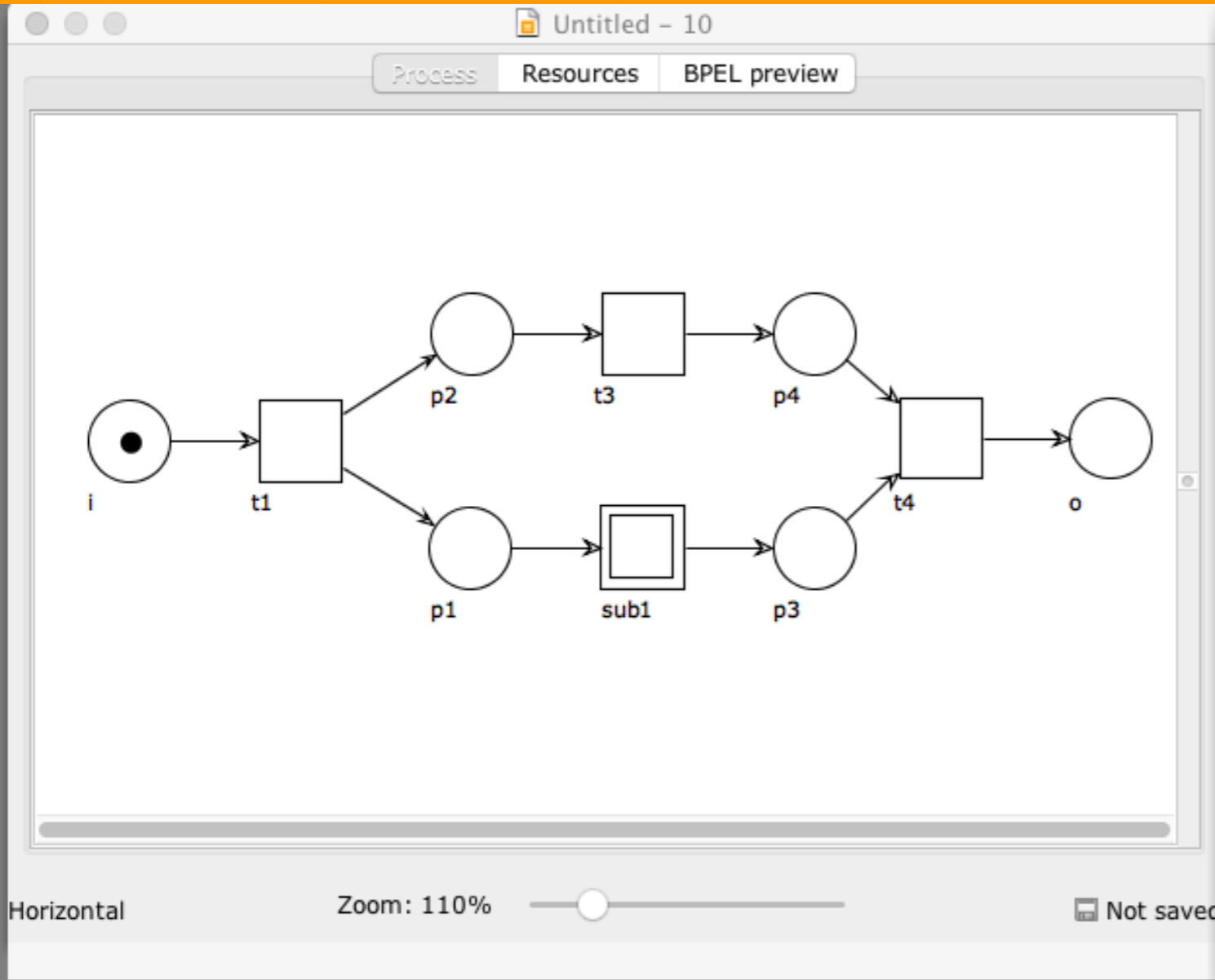

Hierarchical structuring

Uniqueness of entry / exit point facilitate the hierarchical structuring of WF nets

a transition can be realized by another workflow net

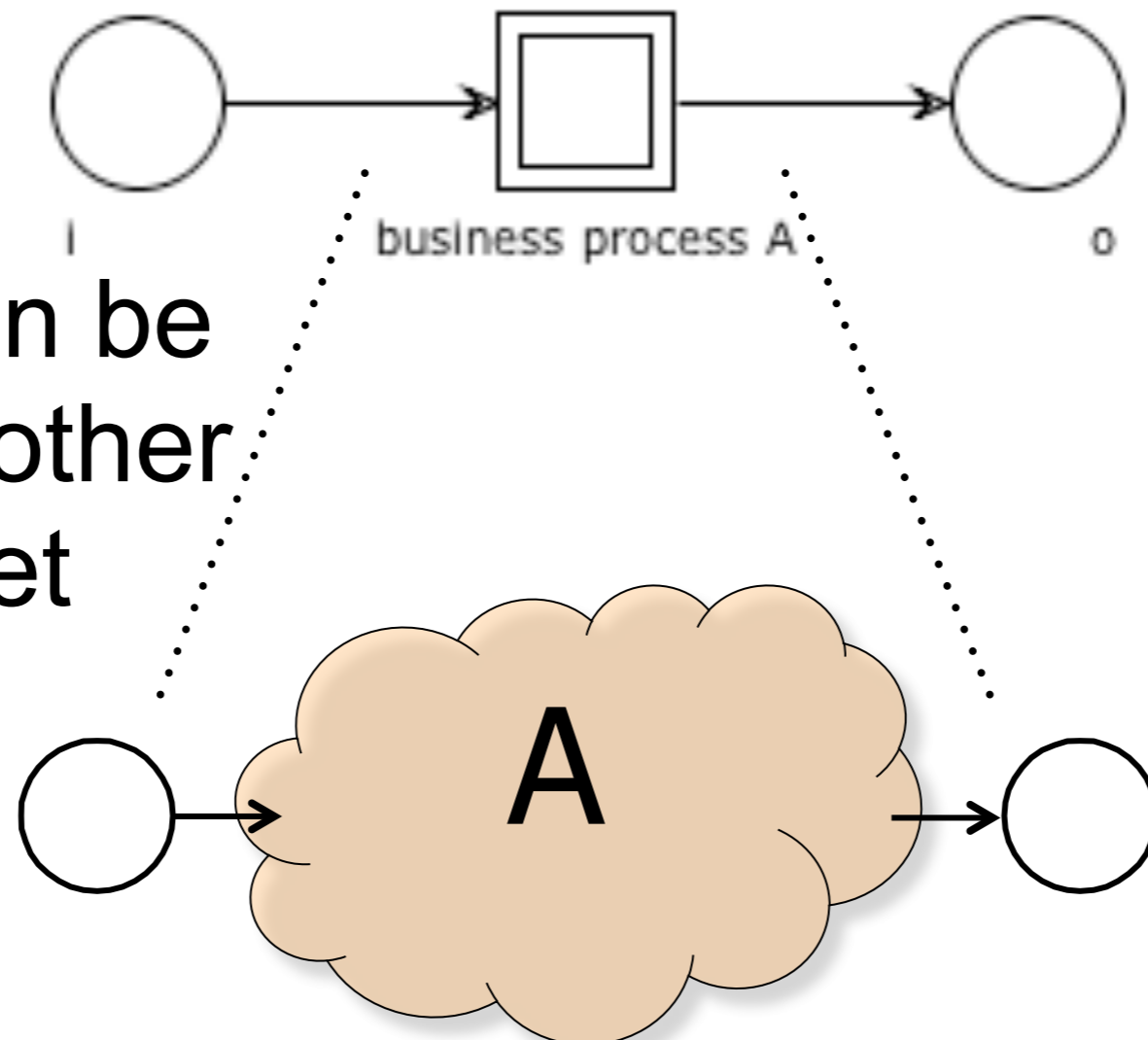

$L(N)$

Language of a workflow net

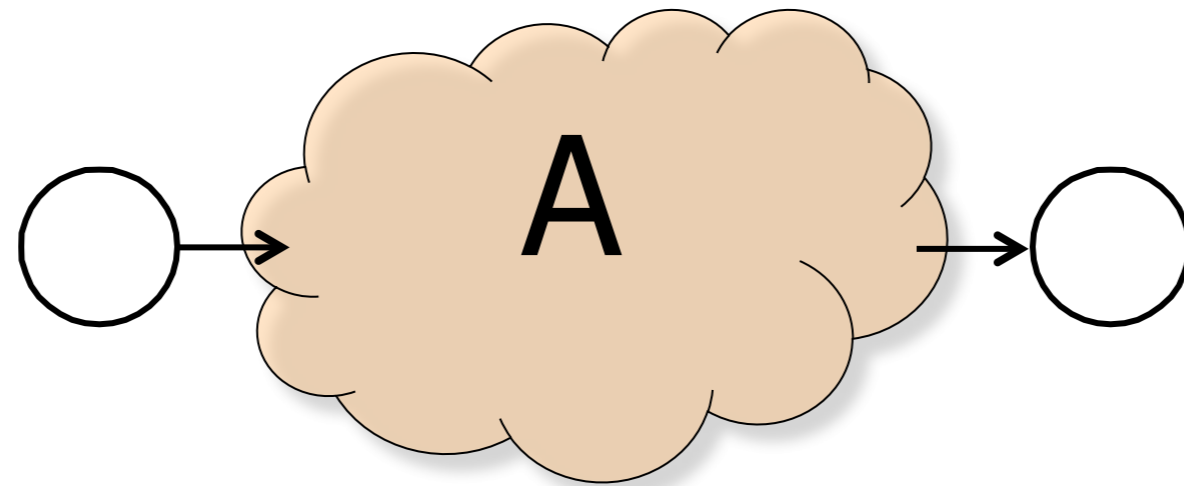

The language of a workflow net is the set of firing sequences that lead from marking i to marking o

$$L(N) = \{ \sigma \mid i \xrightarrow{\sigma} o \}$$

$L(N)$ defines all the admissible traces of the workflow

Question time: $L(N)$

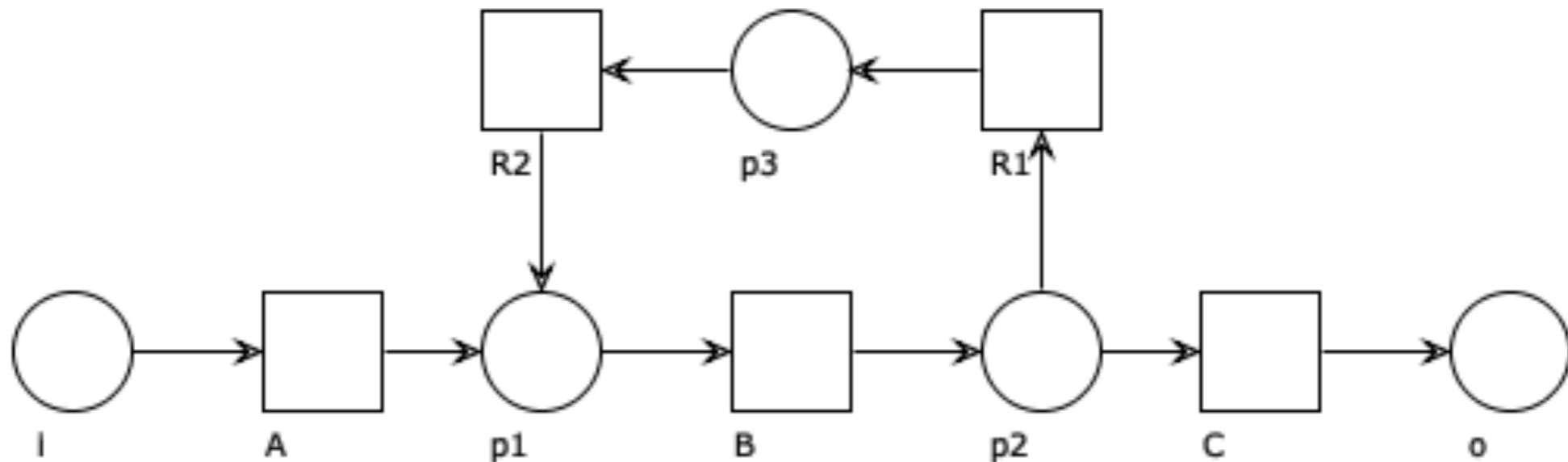

$$L(N) \stackrel{?}{=} \{A (B R1 R2)^k C \mid k \geq 0\}$$

No

$$L(N) \stackrel{?}{=} \{A (B R1 R2 B)^k C \mid k \geq 0\}$$

No

$$L(N) \stackrel{?}{=} \{A B (R1 R2 B)^k C \mid k \geq 0\}$$

Yes

$$L(N) \stackrel{?}{=} \{A (B R1 R2)^k B C \mid k \geq 0\}$$

Yes

Some patterns

Typical control flow aspects

Sequencing

Parallelism (AND-split + AND-join)

Selection (XOR-split + XOR-join)

Iteration (XOR-join + XOR-split)

Capacity constraints:

Feedback loop

Mutual exclusion

Alternating

Sequencing

B is executed after A

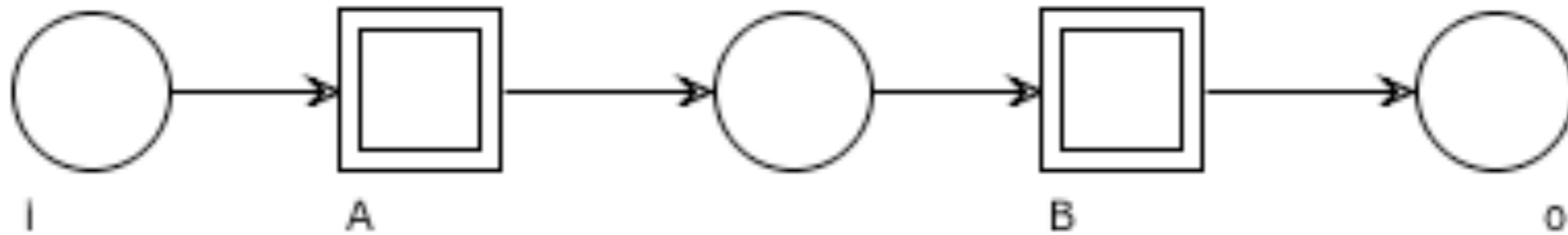

Parallelism

(AND-split + AND-join)

A and B are both executed in no particular order

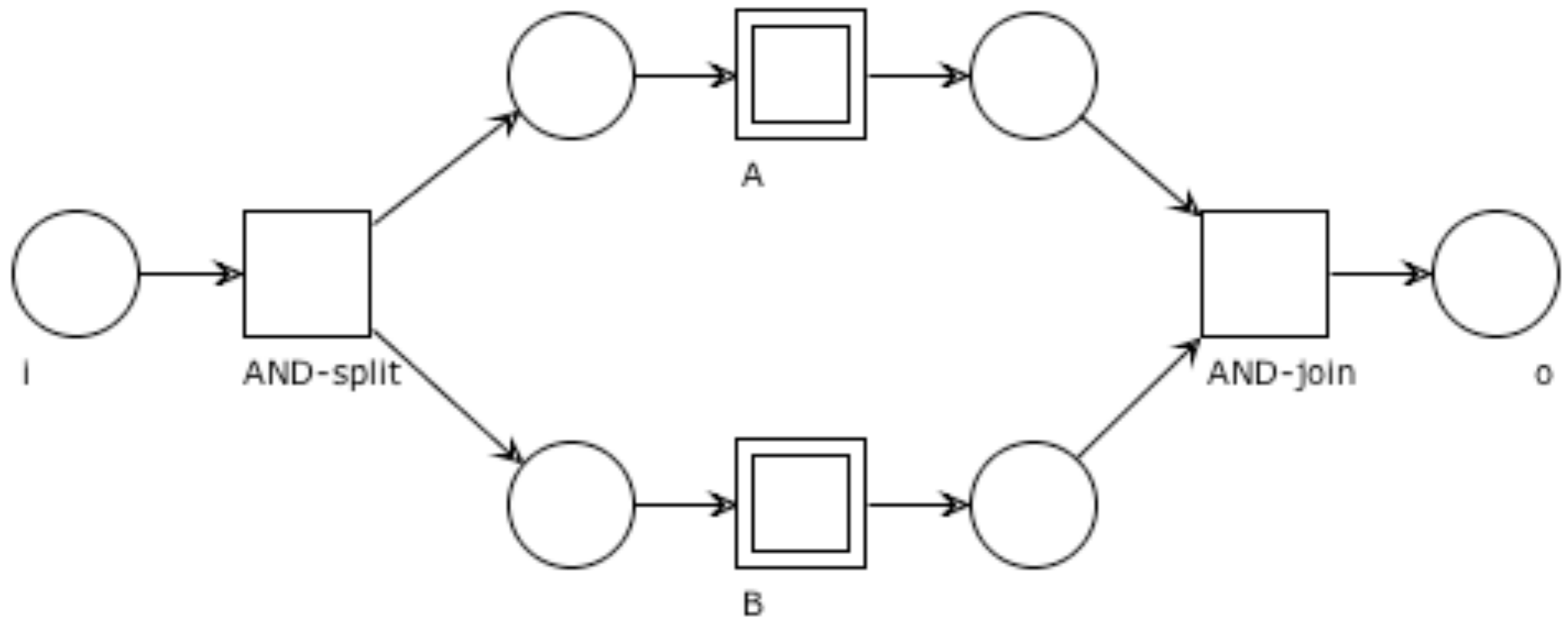

Explicit choice

(XOR-split + XOR-join)

Either A or B is executed (choice is **explicit**)

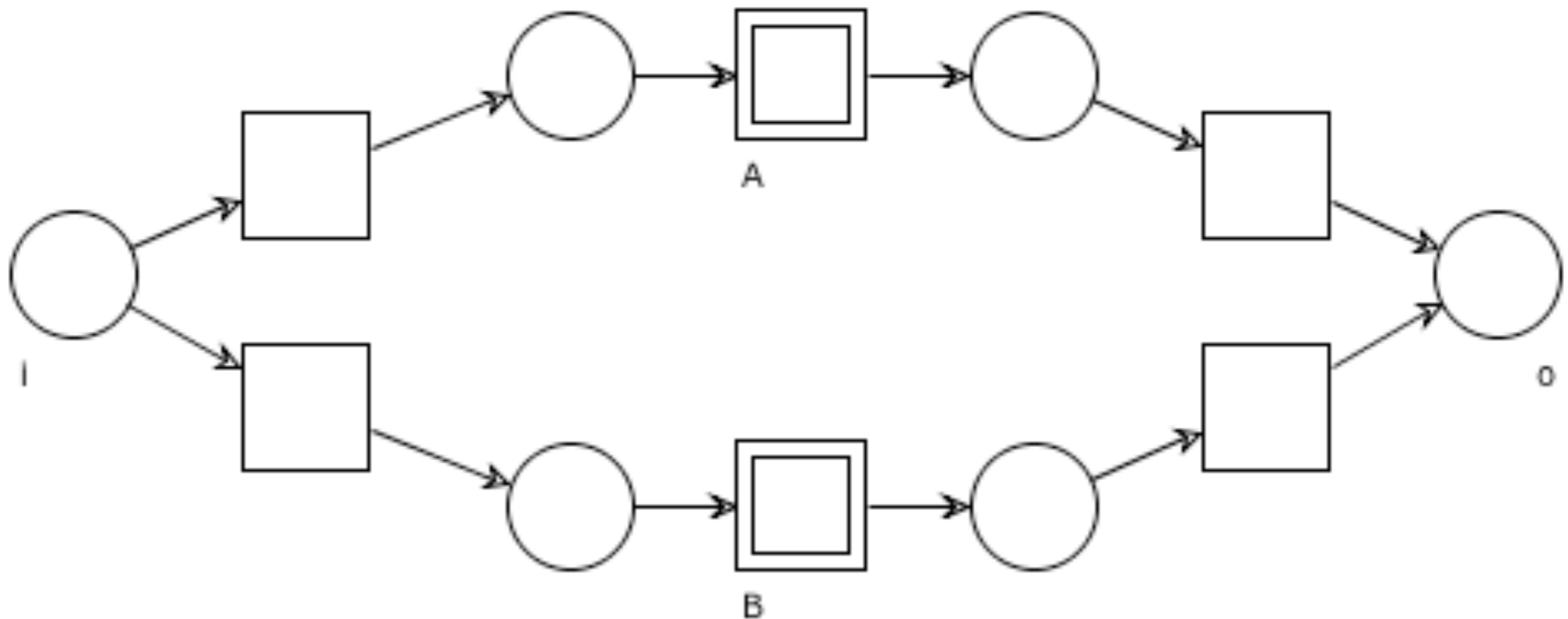

Explicit choice ("sugared" version)

Decorated version

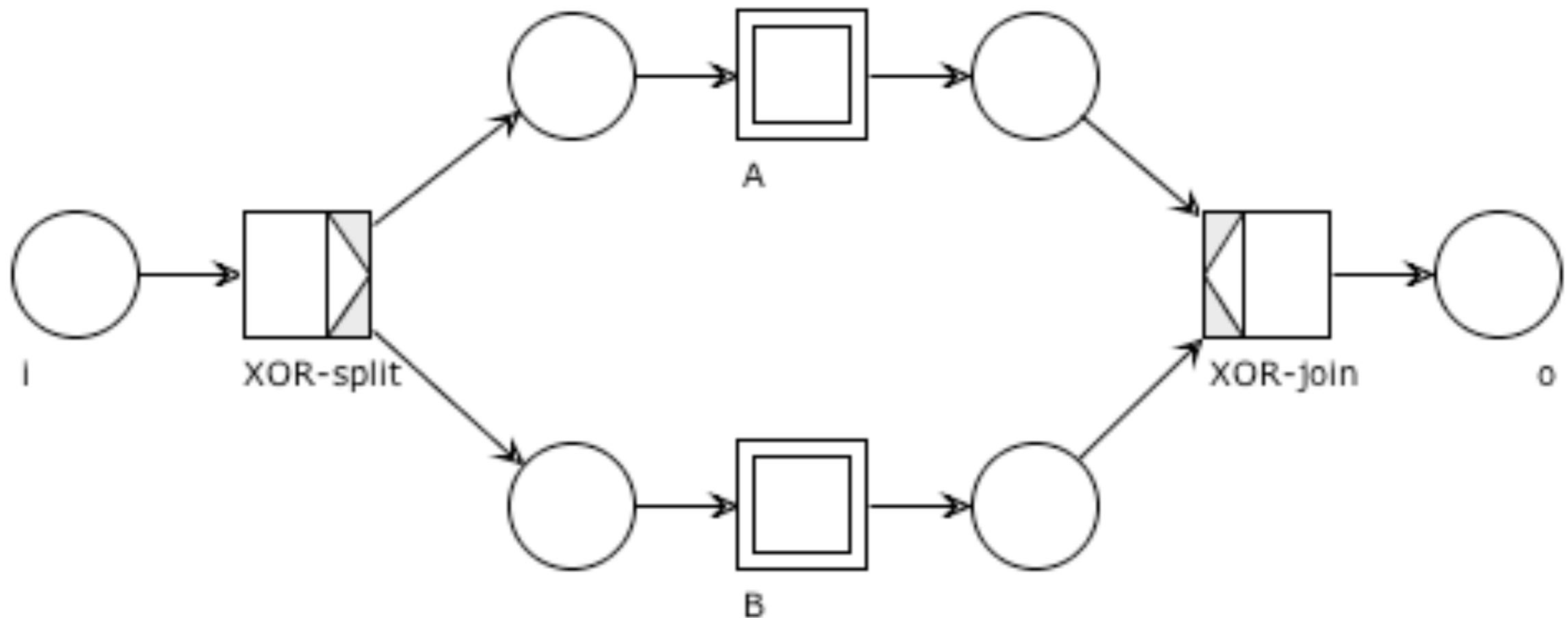

Deferred choice

Either A or B is executed (choice is **implicit**)

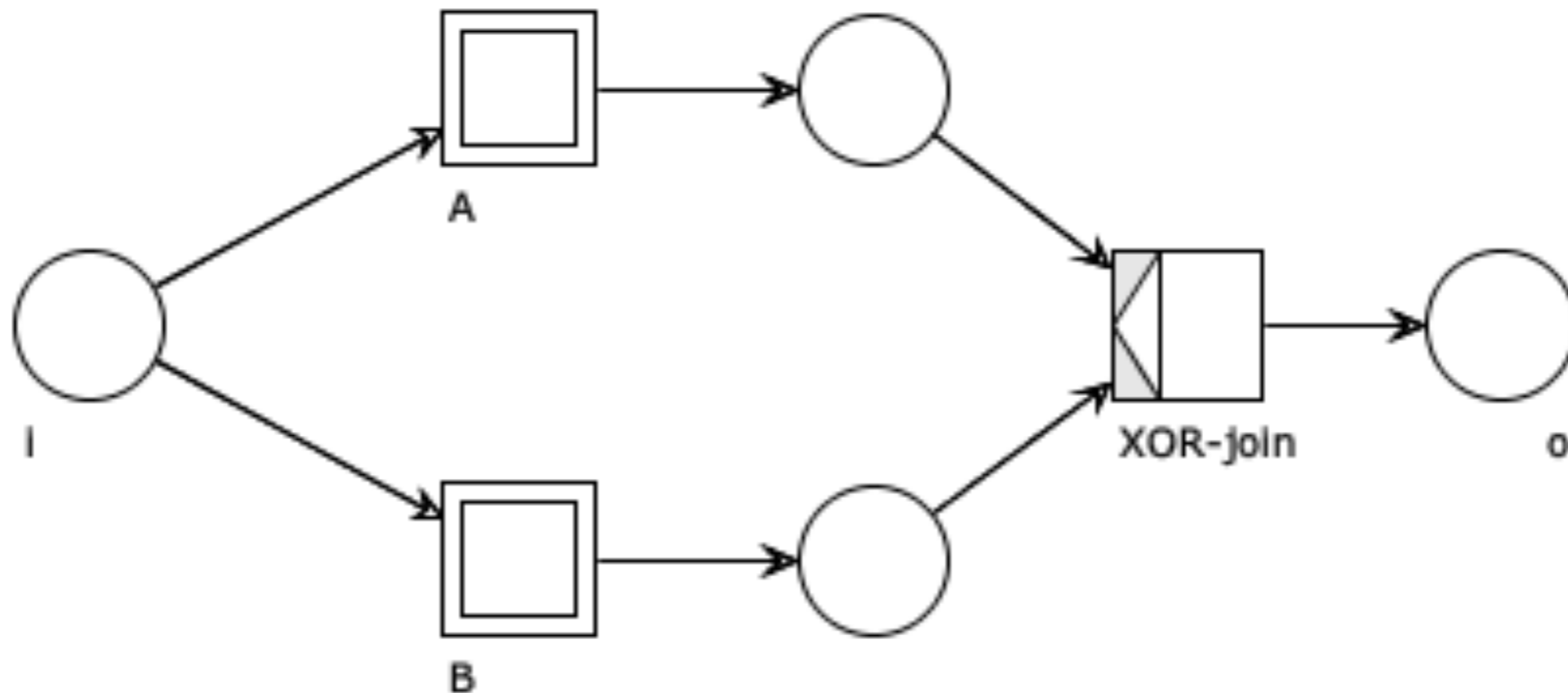

Remember

Explicit choice \neq Implicit choice



XOR

T chooses

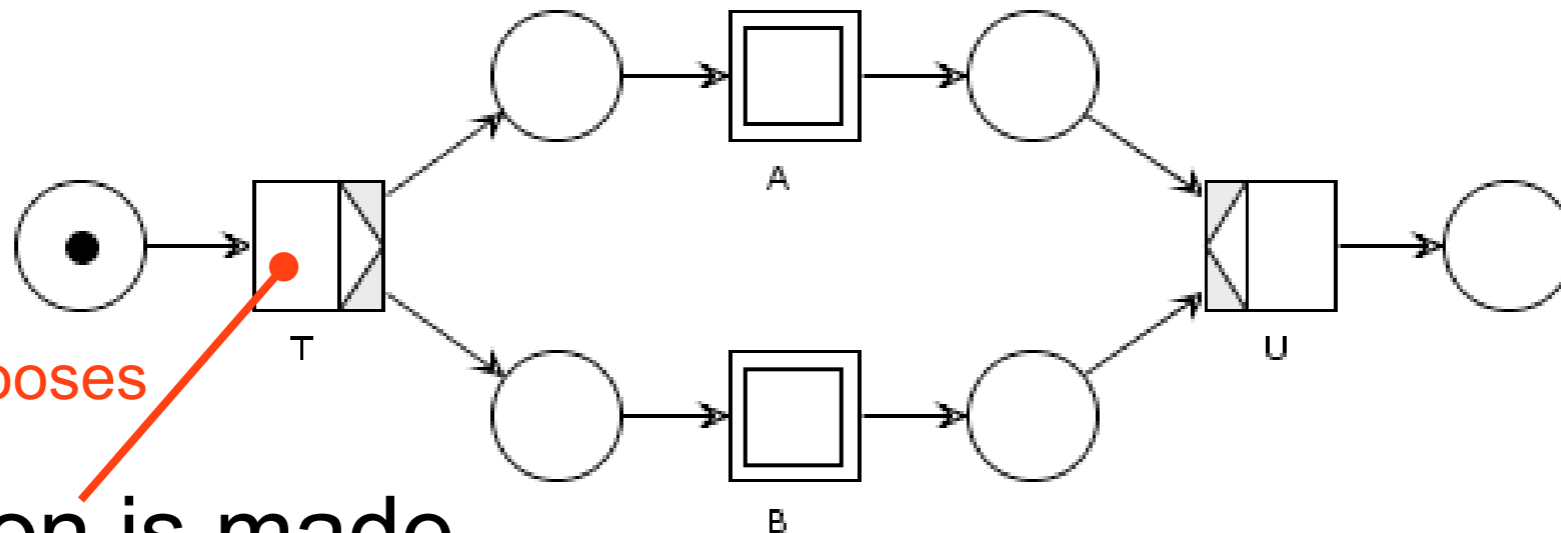

The decision is made
at different points in time



event
based

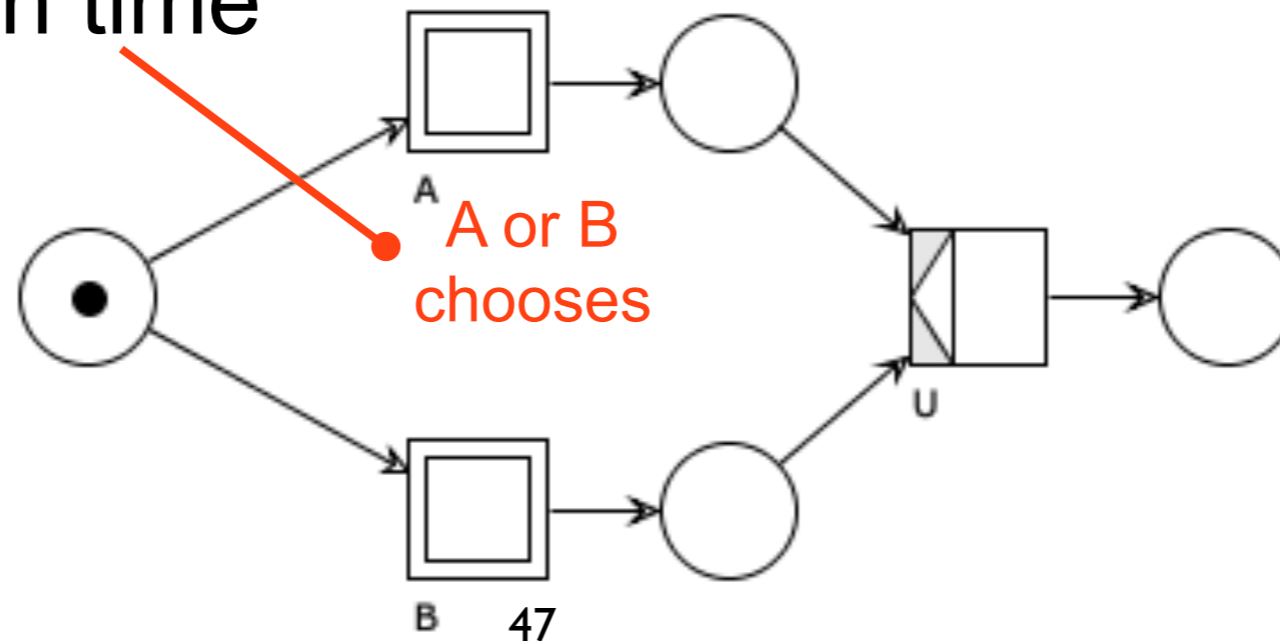

Iteration (one or more times)

A is executed 1 or more times

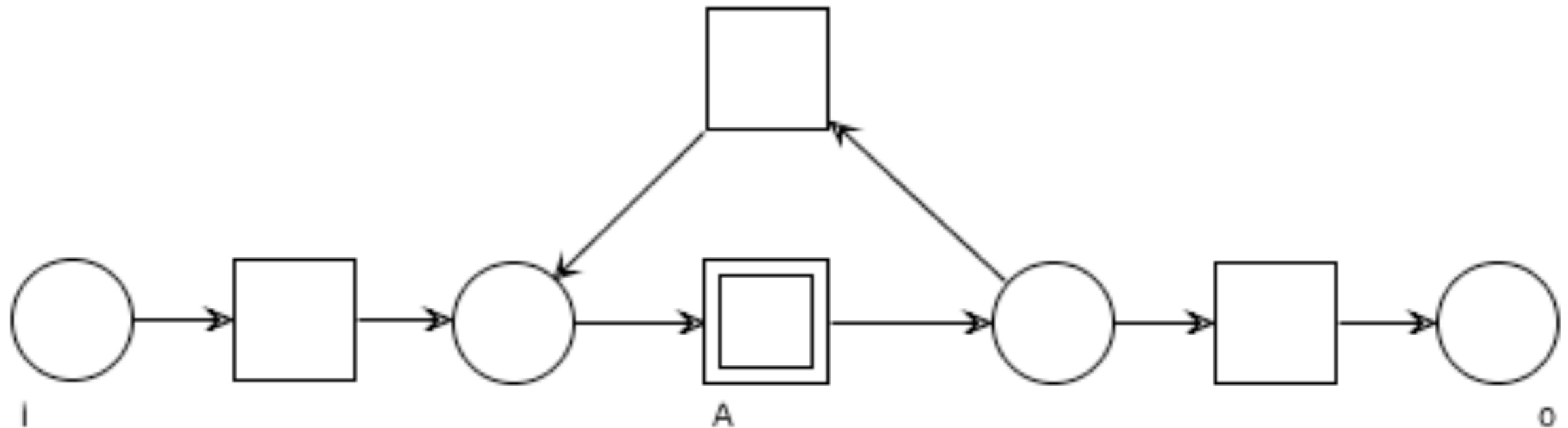

One-or-more iteration ("sugared" version)

Decorated version

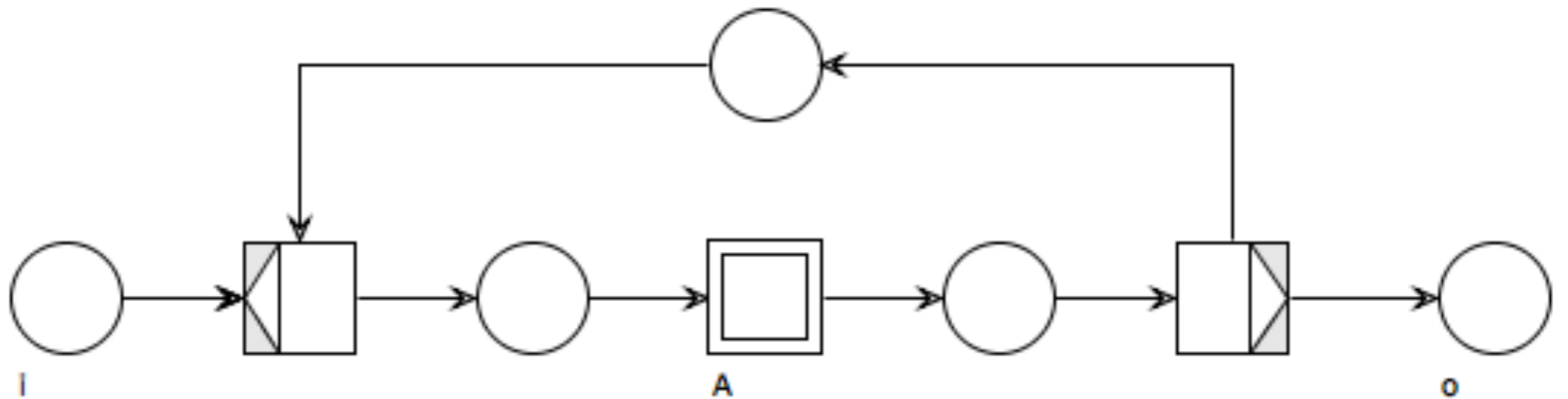

One-or-more iteration

BPMN-like version

Decorated version

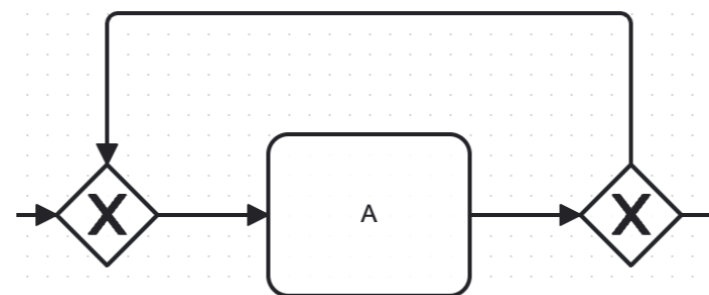
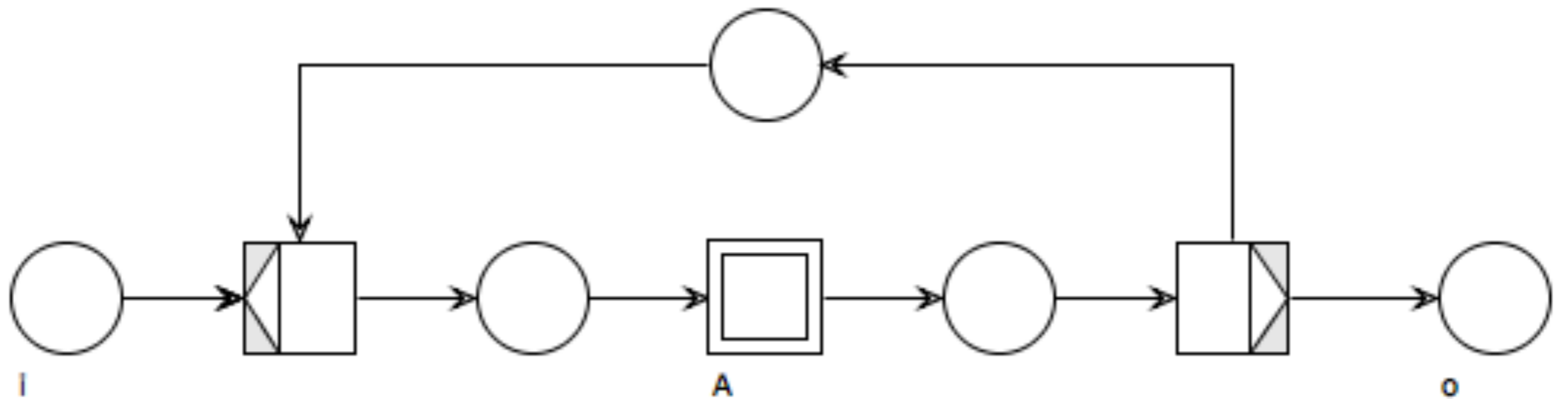

Iteration (zero or more times)

A is executed 0 or more times

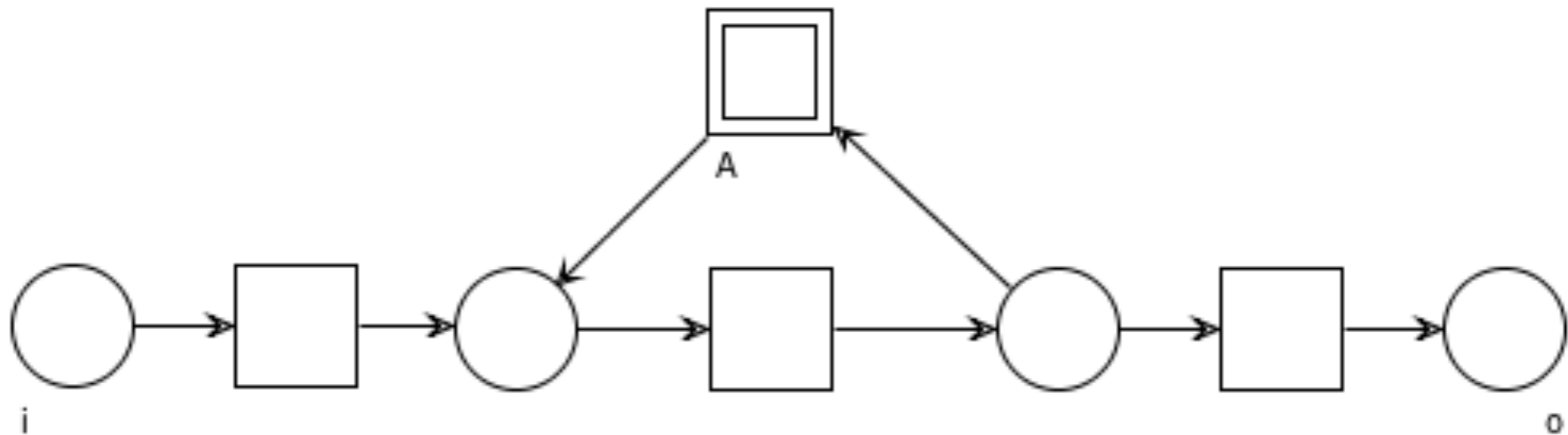

Zero-or-more iteration ("sugared" version)

Decorated version

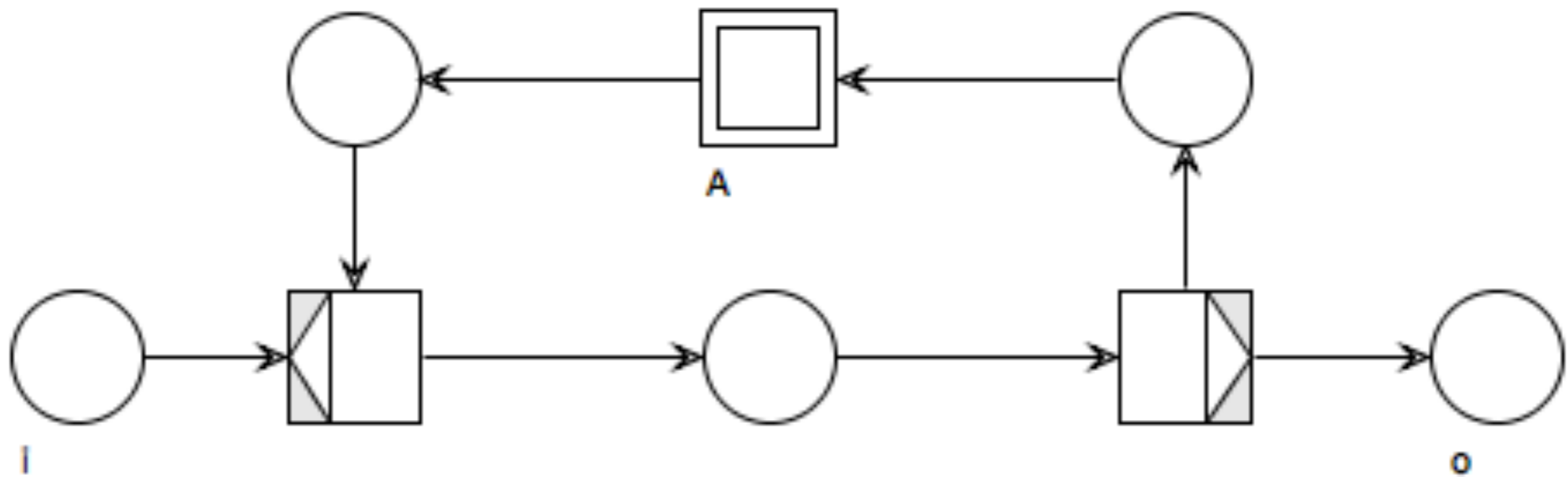

Zero-or-more iteration

BPMN-like version

Decorated version

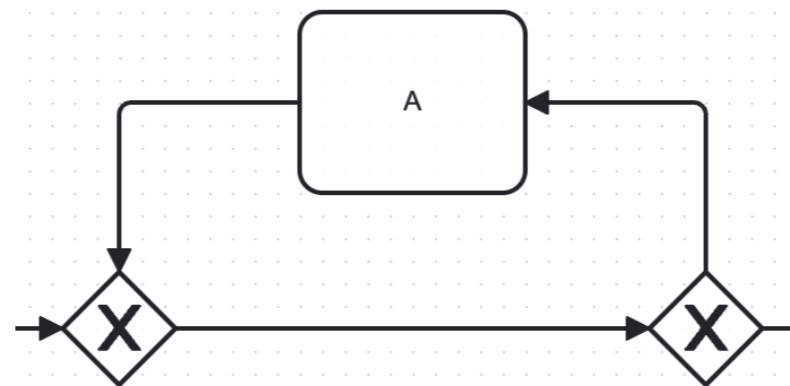
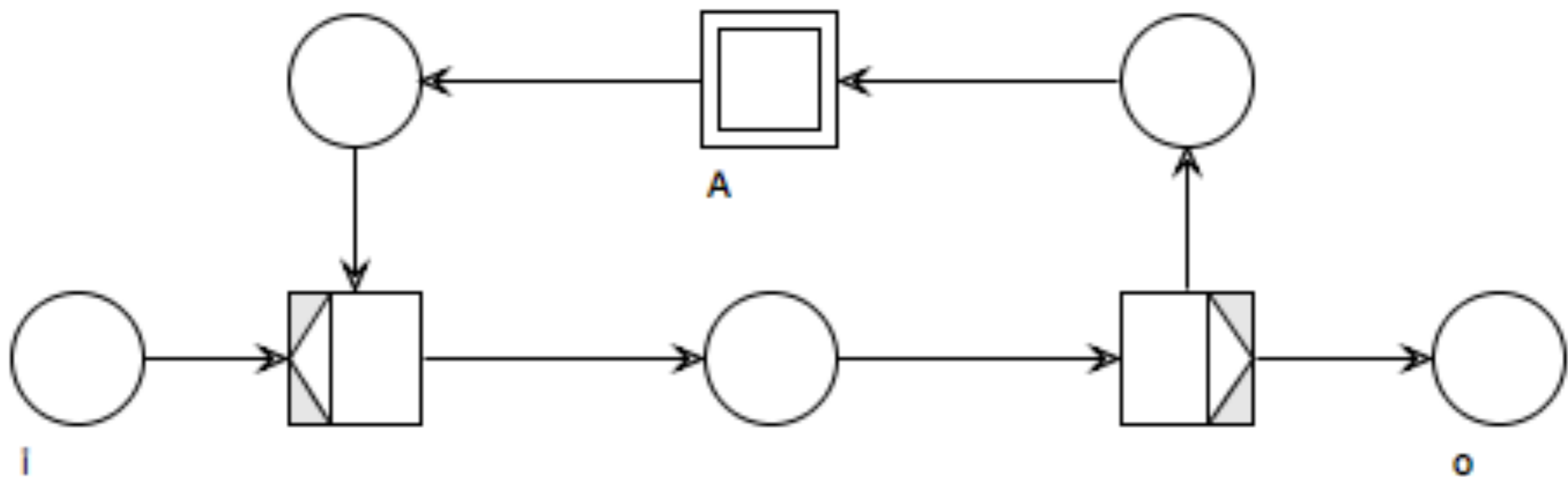

One serve per time

Multiple activations are handled one by one

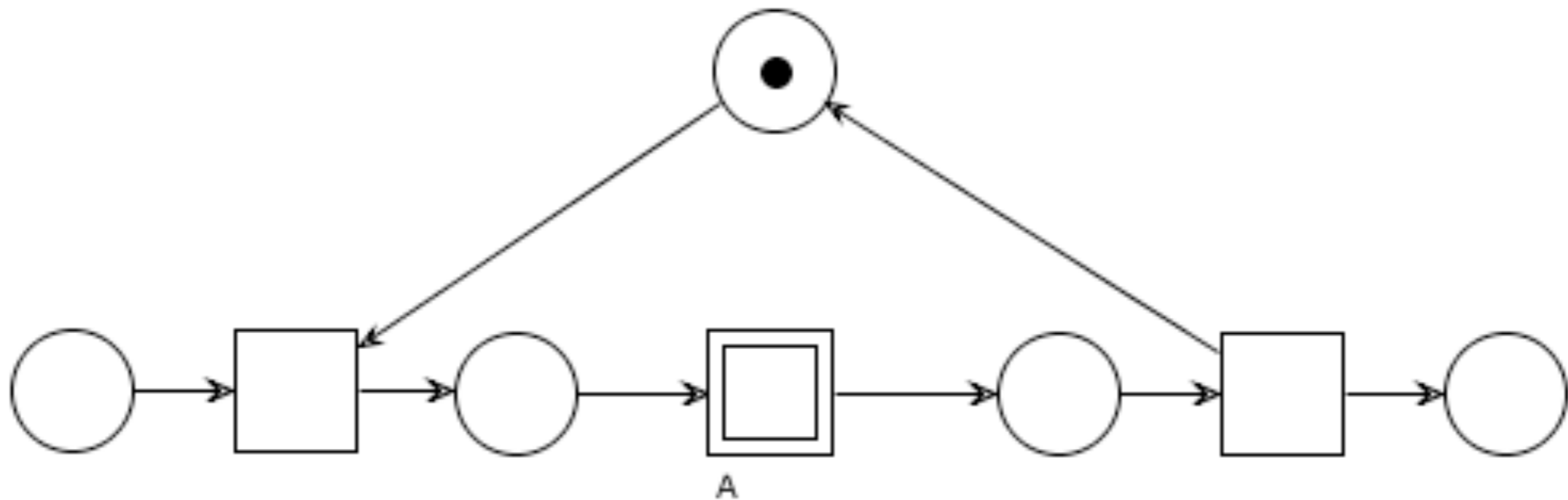

Mutual exclusion

A and B cannot execute concurrently

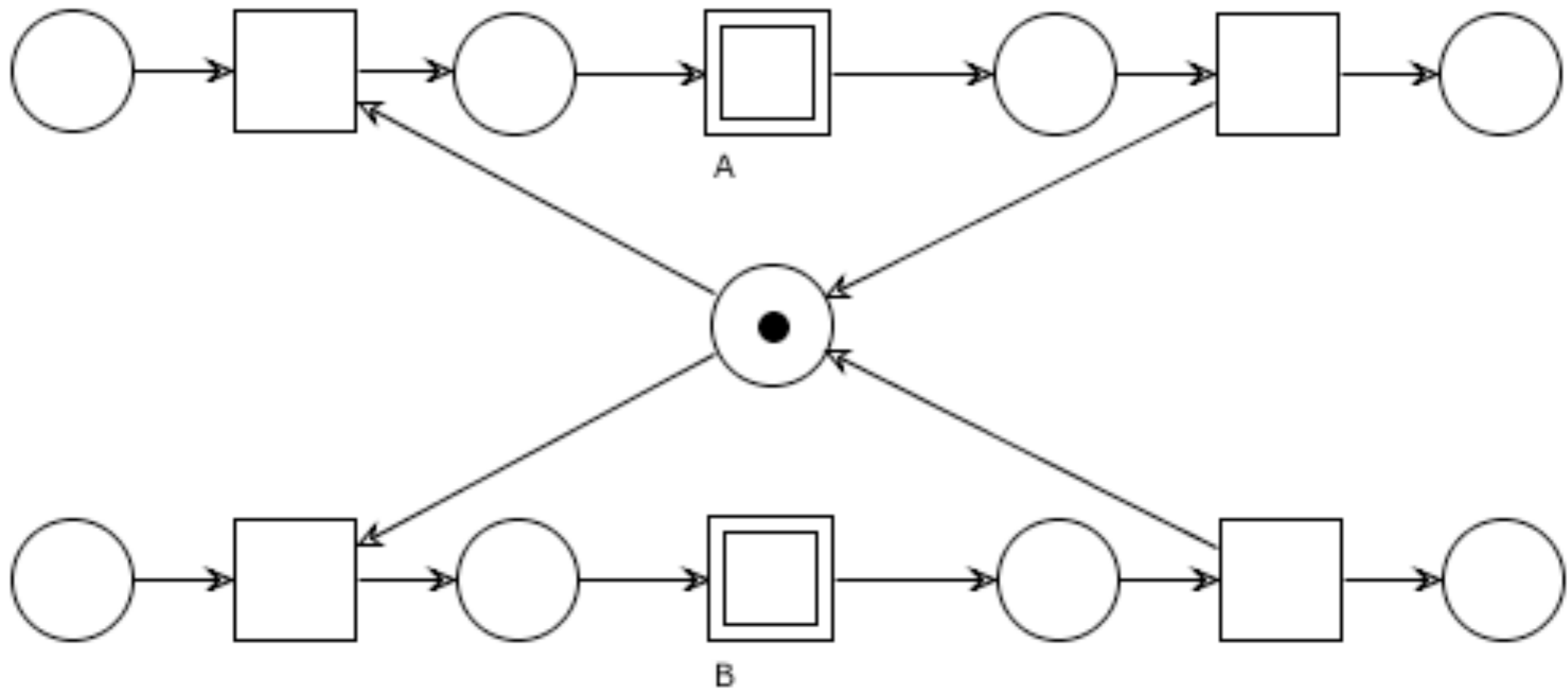

Alternation

A and B execute one time each (A first)

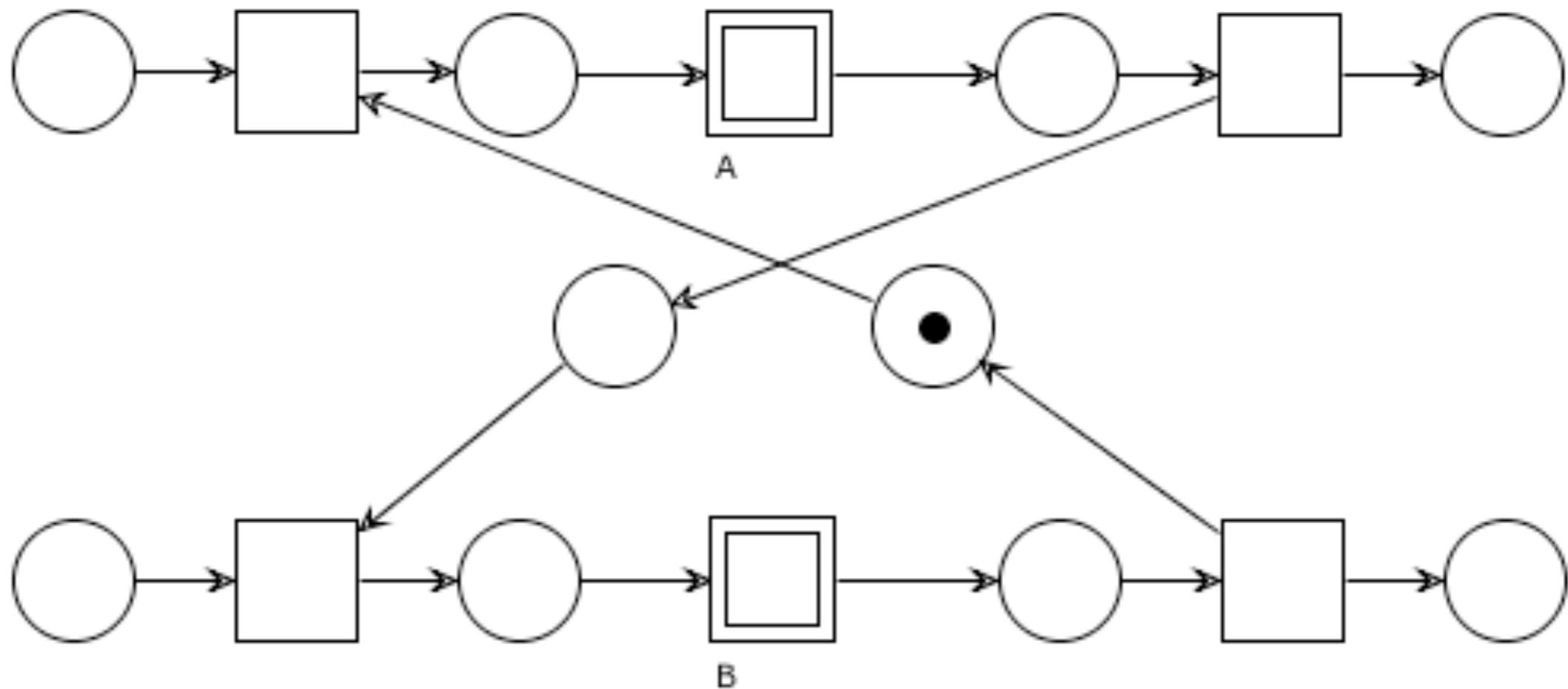

Question time

Consider the workflow net below

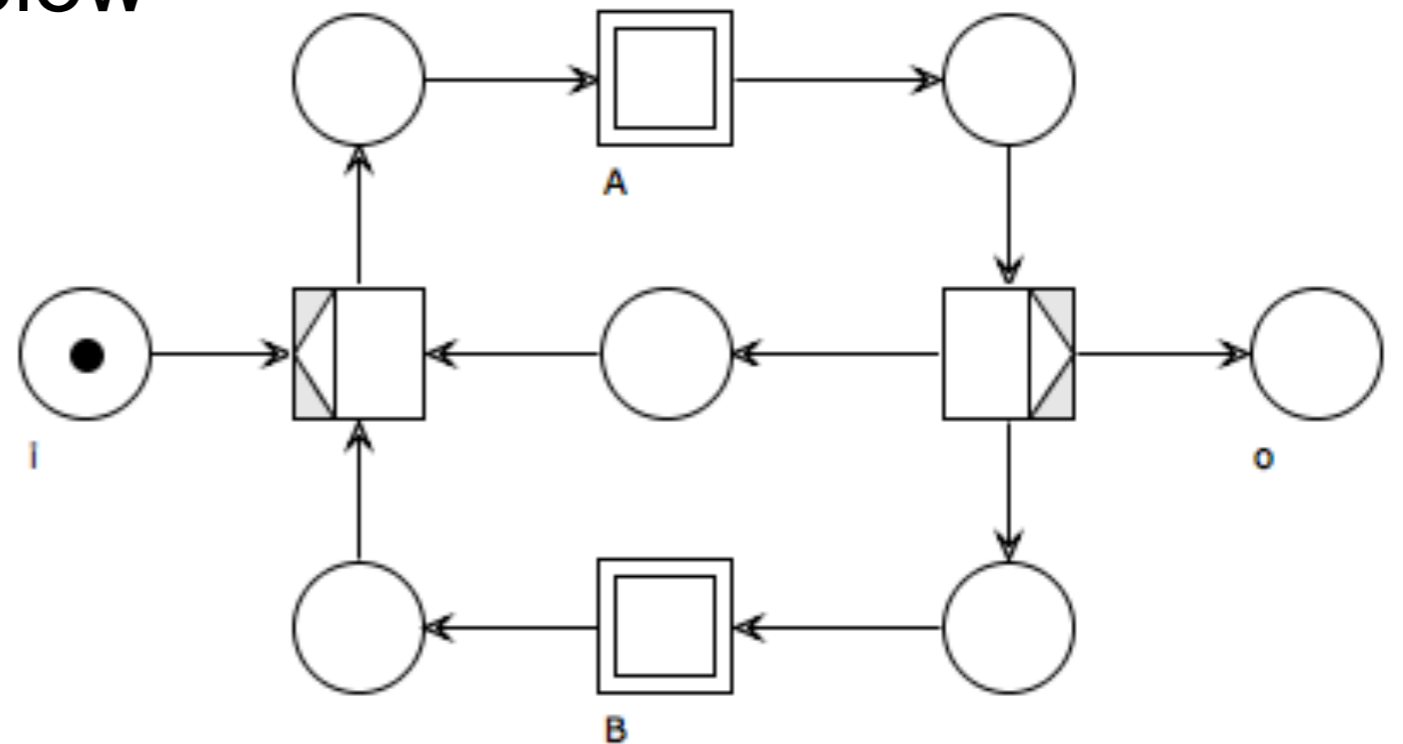

How many times can A be executed?

How many times can B be executed?

Can a firing sequence contain two As in a row?

Can a firing sequence contain two Bs in a row?

Can a firing sequence contain more Bs than As?

Question time

Consider the workflow net below

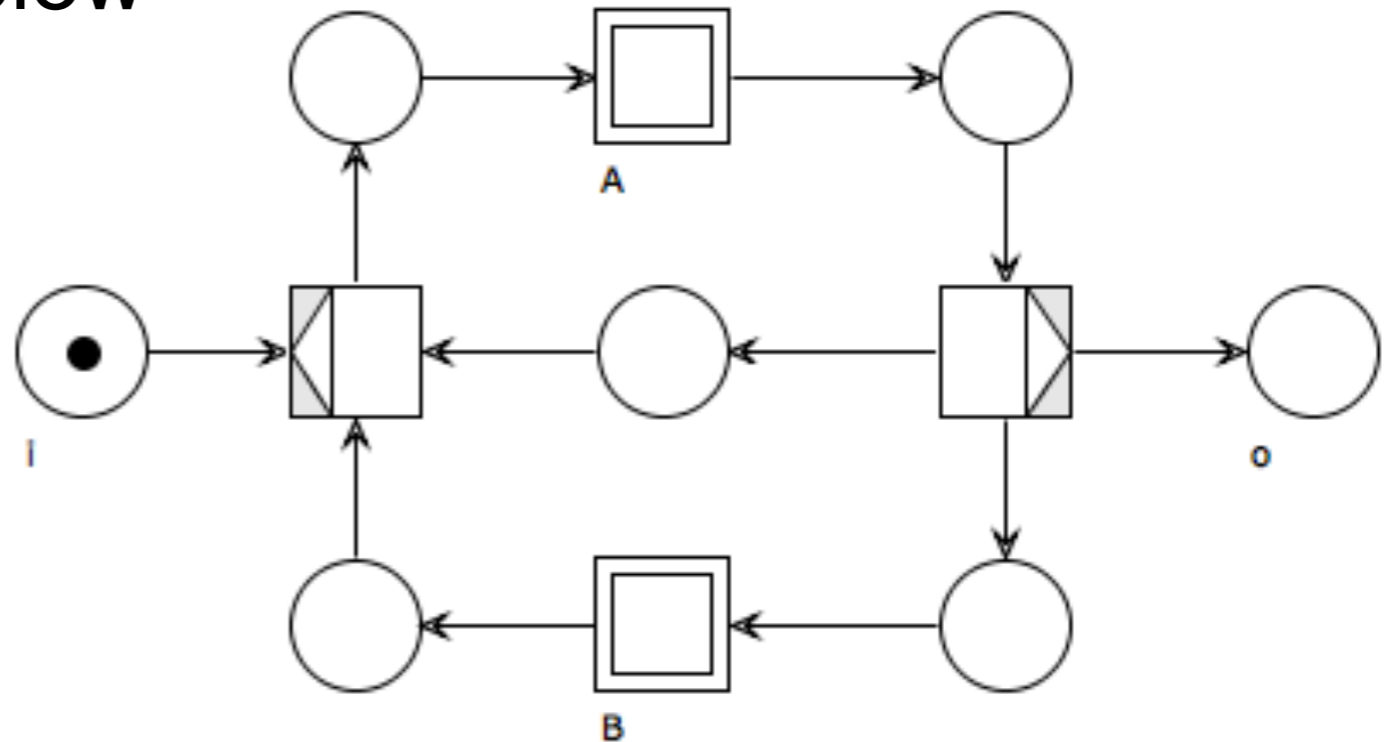

How many times can A be executed? **1 or more**

How many times can B be executed? **0 or more**

Can a firing sequence contain two As in a row? **yes**

Can a firing sequence contain two Bs in a row? **no**

Can a firing sequence contain more Bs than As? **no**

Exercises

- Which "patterns" can be found in the workflow net below?
- Draw the corresponding Reachability Graph
- What is its language?

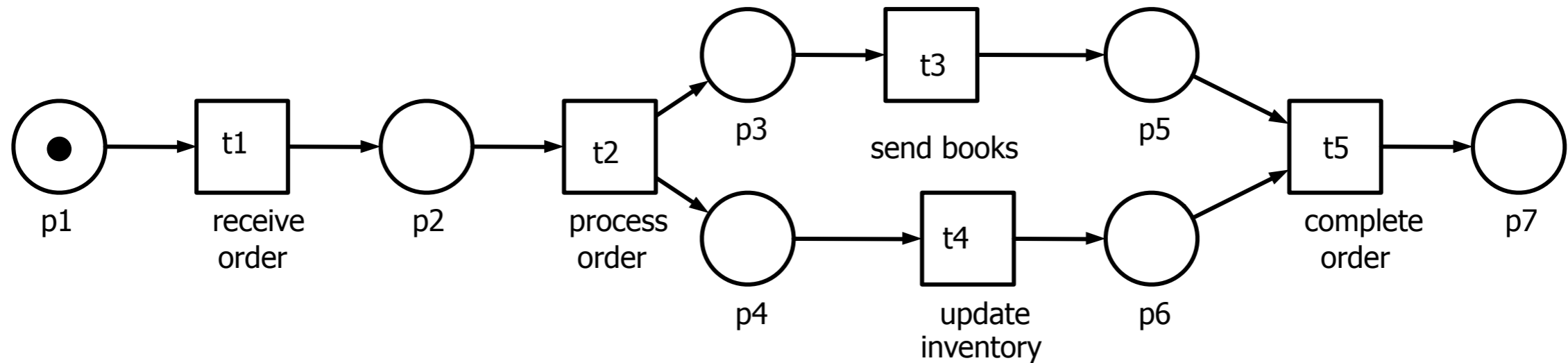

Exercises

- Which "patterns" can be found in the workflow net below?
- "Sugarize" the net (where it makes sense)
- Name all places and draw the Reachability Graph
- What is its language?

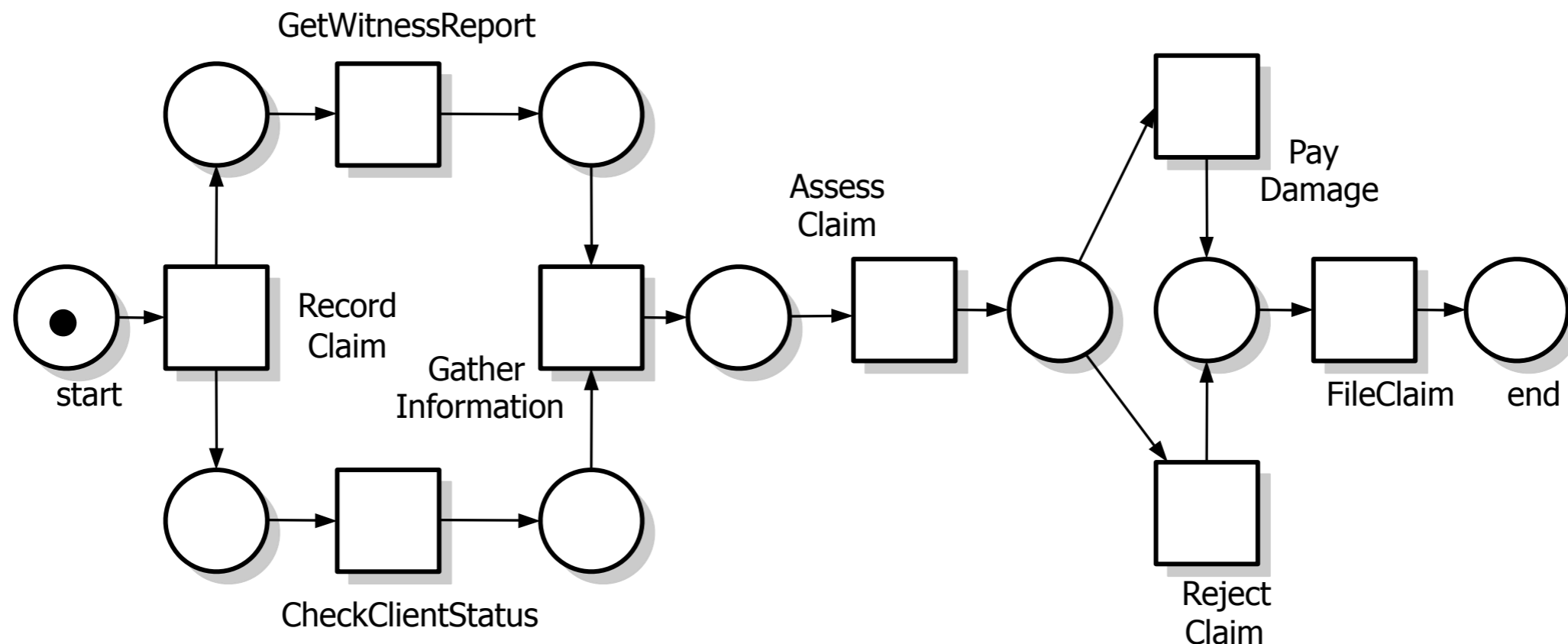

Exercises

- "Desugarize" the workflow net below
- Name all nodes and draw the Reachability Graph
- What is its language?

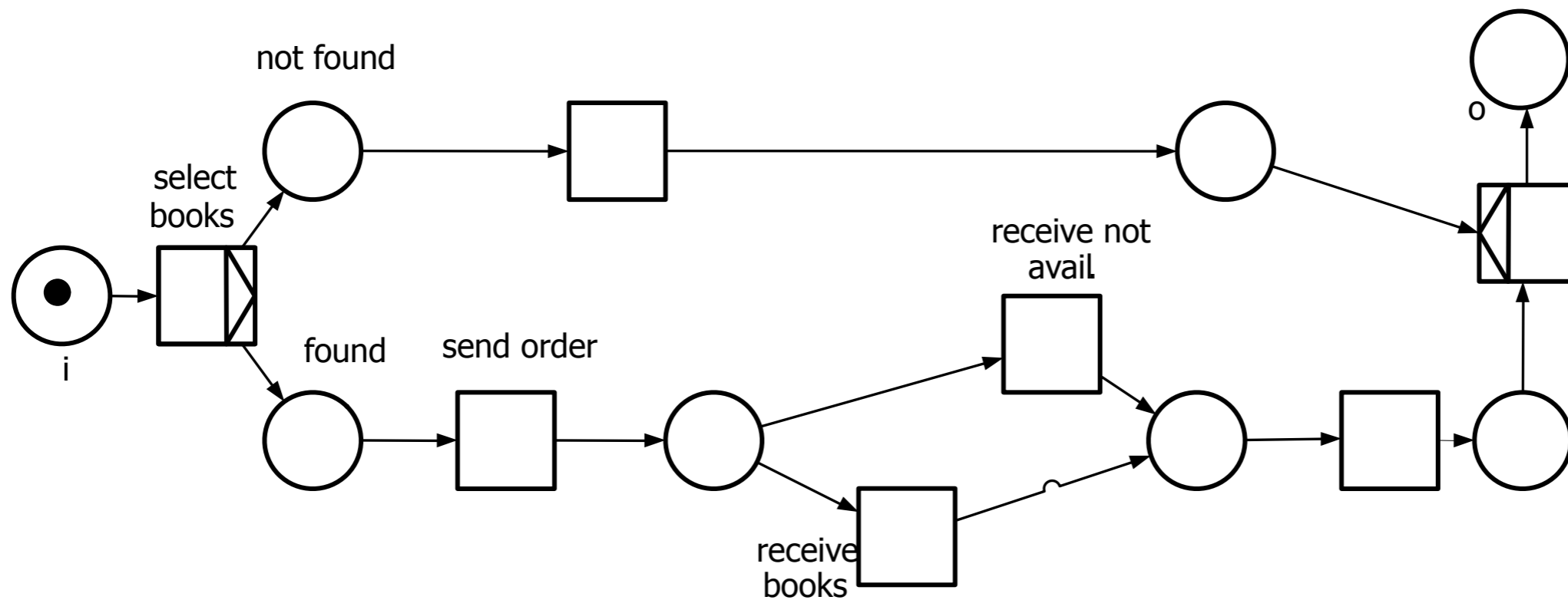

Exercises

- "Desugarize" the workflow nets below
- Name all nodes and draw the Reachability Graphs
- What are their languages?

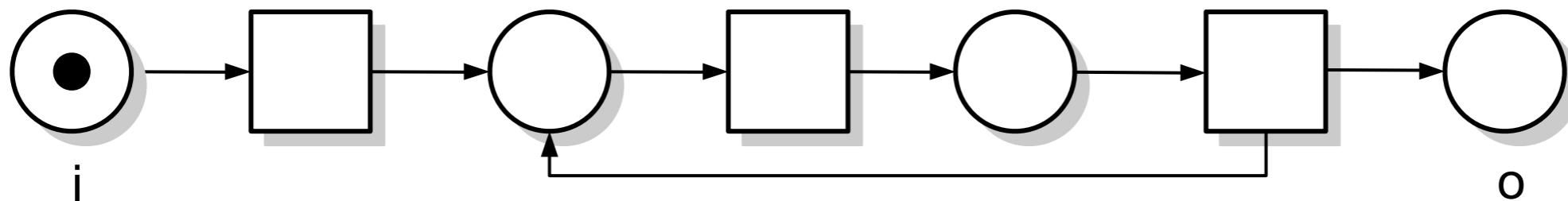
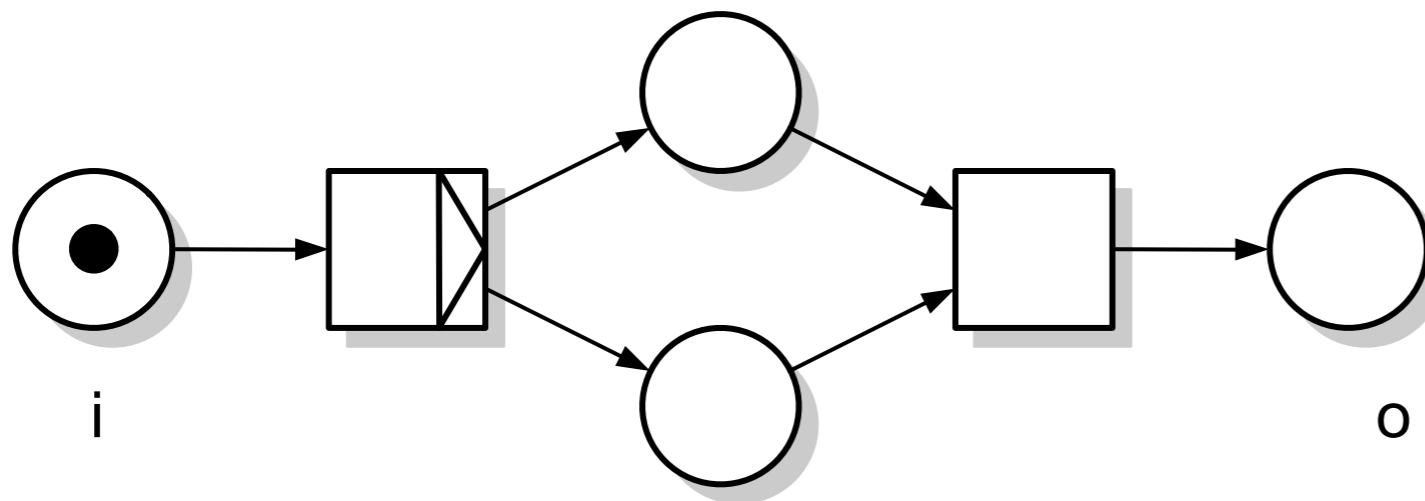

Triggers

<http://woped.dhbw-karlsruhe.de/woped/>

WoPeD



Workflow Petri Net Designer

Download WoPeD at sourceforge!



Transition properties

Identification

Name: ID#:

Branching

<input checked="" type="radio"/> None <input type="checkbox"/>	<input type="radio"/> AND-split <input type="checkbox"/>	<input type="radio"/> AND-join <input type="checkbox"/>
<input type="radio"/> XOR-split <input type="checkbox"/>	<input type="radio"/> XOR-join-split <input type="checkbox"/>	<input type="radio"/> XOR-join <input type="checkbox"/>
<input type="radio"/> XOR-join-split <input type="checkbox"/>	<input type="radio"/> AND-join-XOR-split <input type="checkbox"/>	<input type="radio"/> AND-join-split <input type="checkbox"/>
<input type="radio"/> AND-join-XOR-split <input type="checkbox"/>		<input type="radio"/> XOR-join-AND-split <input type="checkbox"/>

Trigger

<input checked="" type="radio"/> Automatic	<input type="radio"/> Resource	<input type="checkbox"/>
<input type="radio"/> Message <input type="checkbox"/>	<input type="radio"/> Time <input type="checkbox"/>	<input type="checkbox"/>

Triggers

Execution constraints can depend on the environment in which processes are enacted.

In workflow nets, transitions can be decorated with the information on who (or what) is responsible for the "firing" of that task.

Such annotations are called **triggers**

Triggers

Triggers can be:

a human interaction

the receipt of a message

the expiration of a time-out

Transitions with no trigger can fire automatically

Symbols for triggers

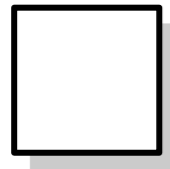

Automatic Trigger: Task enacted automatically

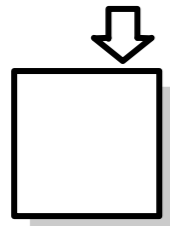

User Trigger: A human user takes initiative and starts activity

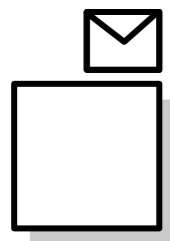

External Trigger: External event required to start activity

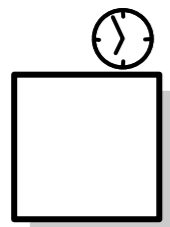

Time Trigger: Activity started when timer elapses

Triggers: example

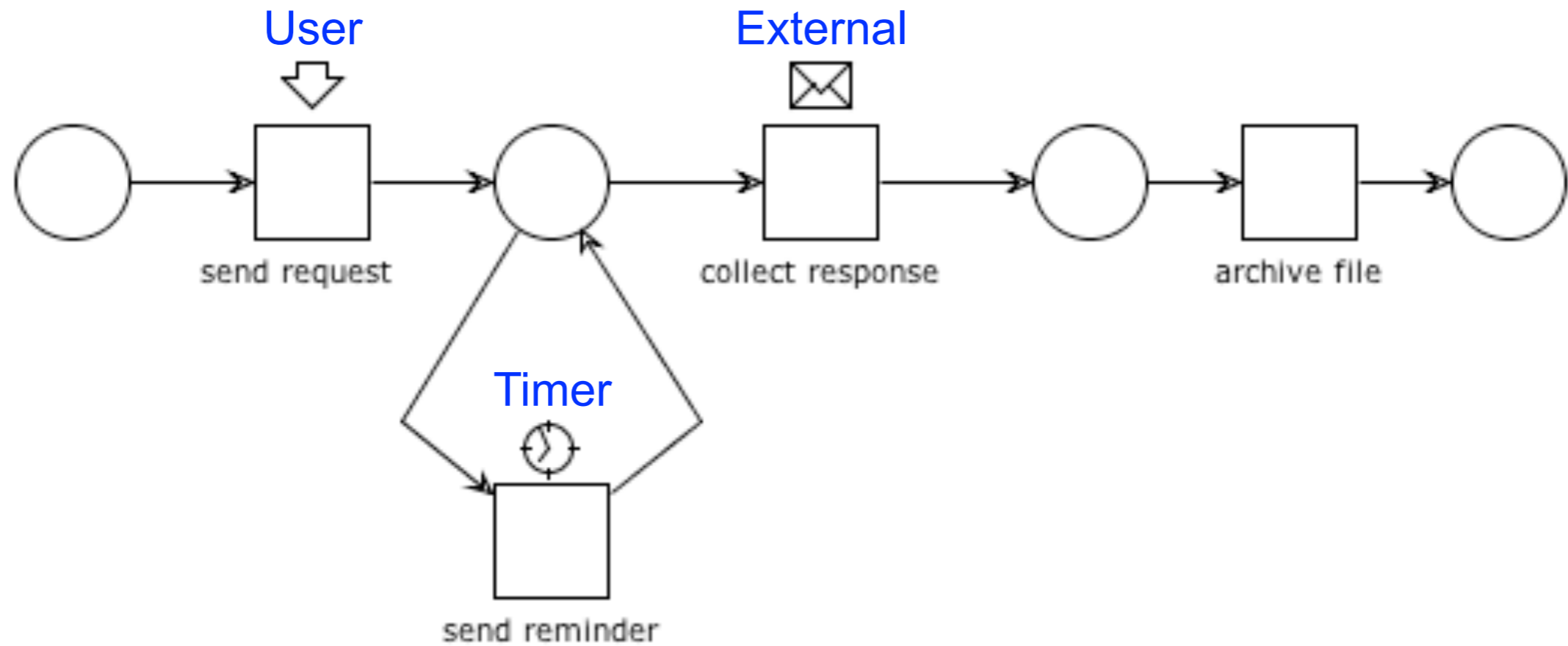

Triggers: example

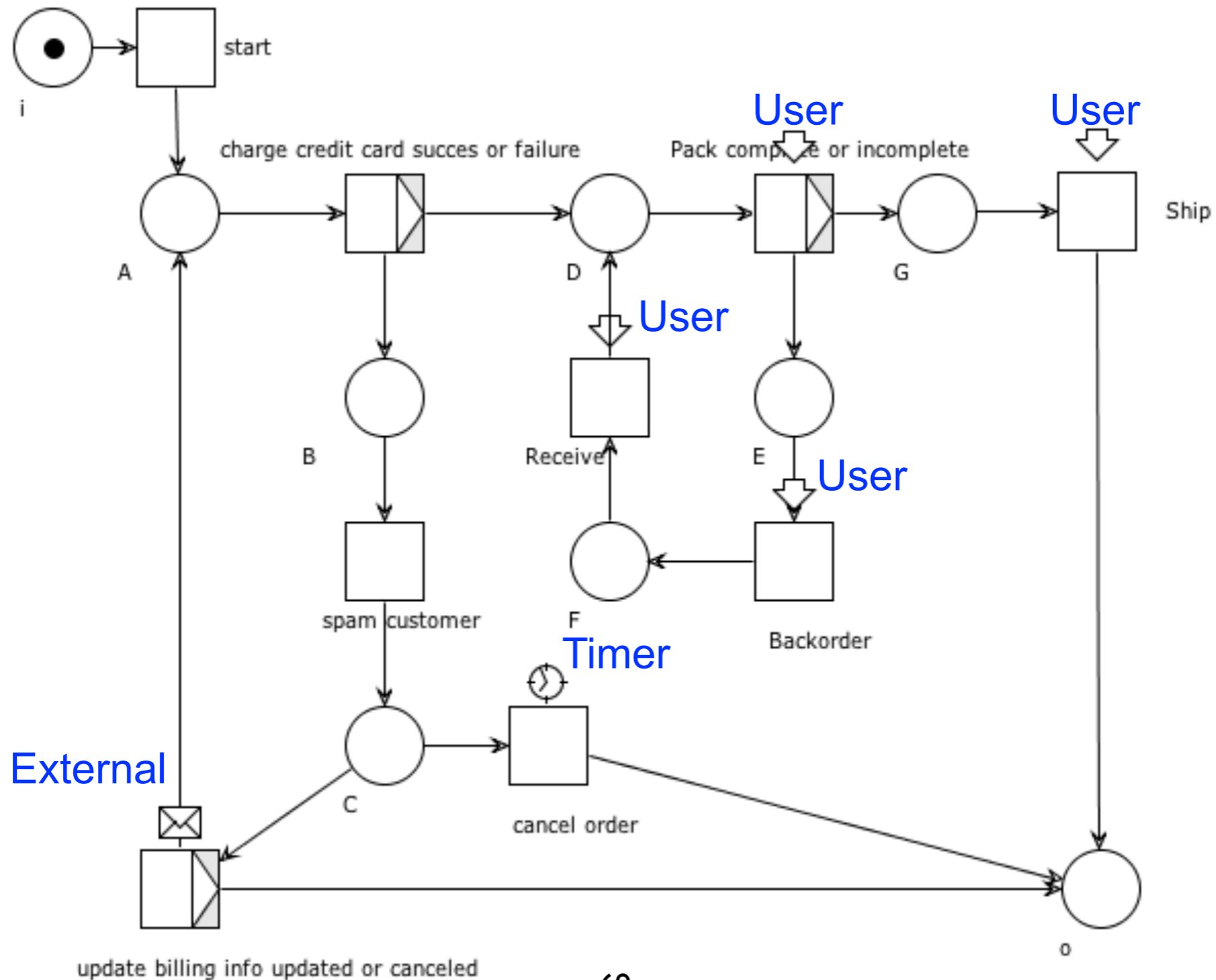

Explicit vs Implicit choices (again)

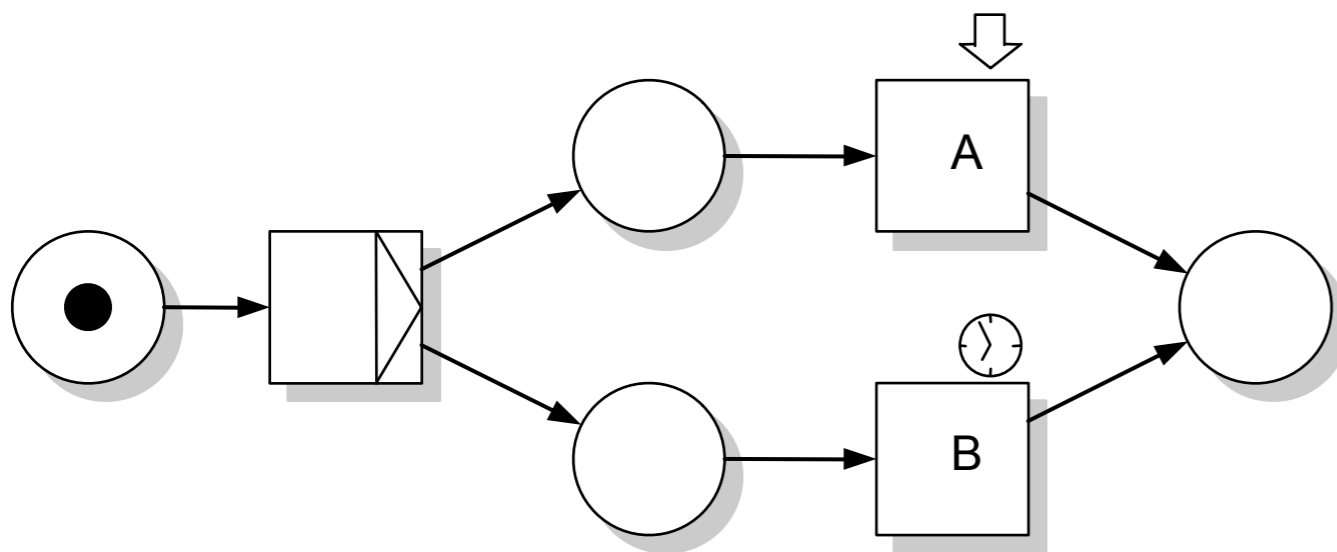

(a) *Explicit xor split* does not enable A and B concurrently

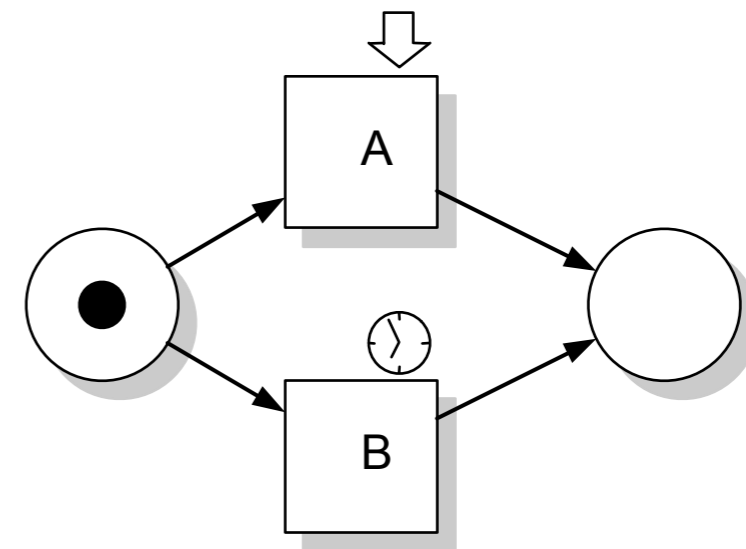

(b) *Implicit xor split* enables A and B concurrently



XOR



event based

Question time

Net design: Car Damage

- An insurance company uses the following procedure for the processing of the claims
- Every claim, reported by a customer, is registered
- After the registration, the claim is classified
- There are two categories: simple and complex claims.
 - For simple claims two tasks need to be executed: check insurance and phone garage.
These tasks are *independent* of each other.
 - The complex claims require three tasks: check insurance, check damage history and phone garage.
These tasks need to be *executed sequentially* in the order specified.
- After executing the two/three tasks a decision is taken with two possible outcomes: OK (positive) or NOK (negative).
- If the decision is positive, then insurance company will pay.
- In any event, the insurance company sends a letter to the customer.

Question time

Net design: Car Damage

- An insurance company uses the following procedure for the processing of the claims
- Every claim, reported by a customer, is **registered**
- After the registration, the claim is **classified**
- There are two categories: **simple** and **complex** claims.
 - For simple claims two tasks need to be executed: **check insurance** and **phone garage**.
These tasks are *independent* of each other.
 - The complex claims require three tasks: **check insurance**, **check damage history** and **phone garage**.
These tasks need to be *executed sequentially* in the order specified.
- After executing the two/three tasks a **decision** is taken with two possible outcomes: **OK** (positive) or **NOK** (negative).
- If the decision is positive, then insurance company will **pay**.
- In any event, the insurance company **sends a letter** to the customer.

Question time

Net design: Car Damage

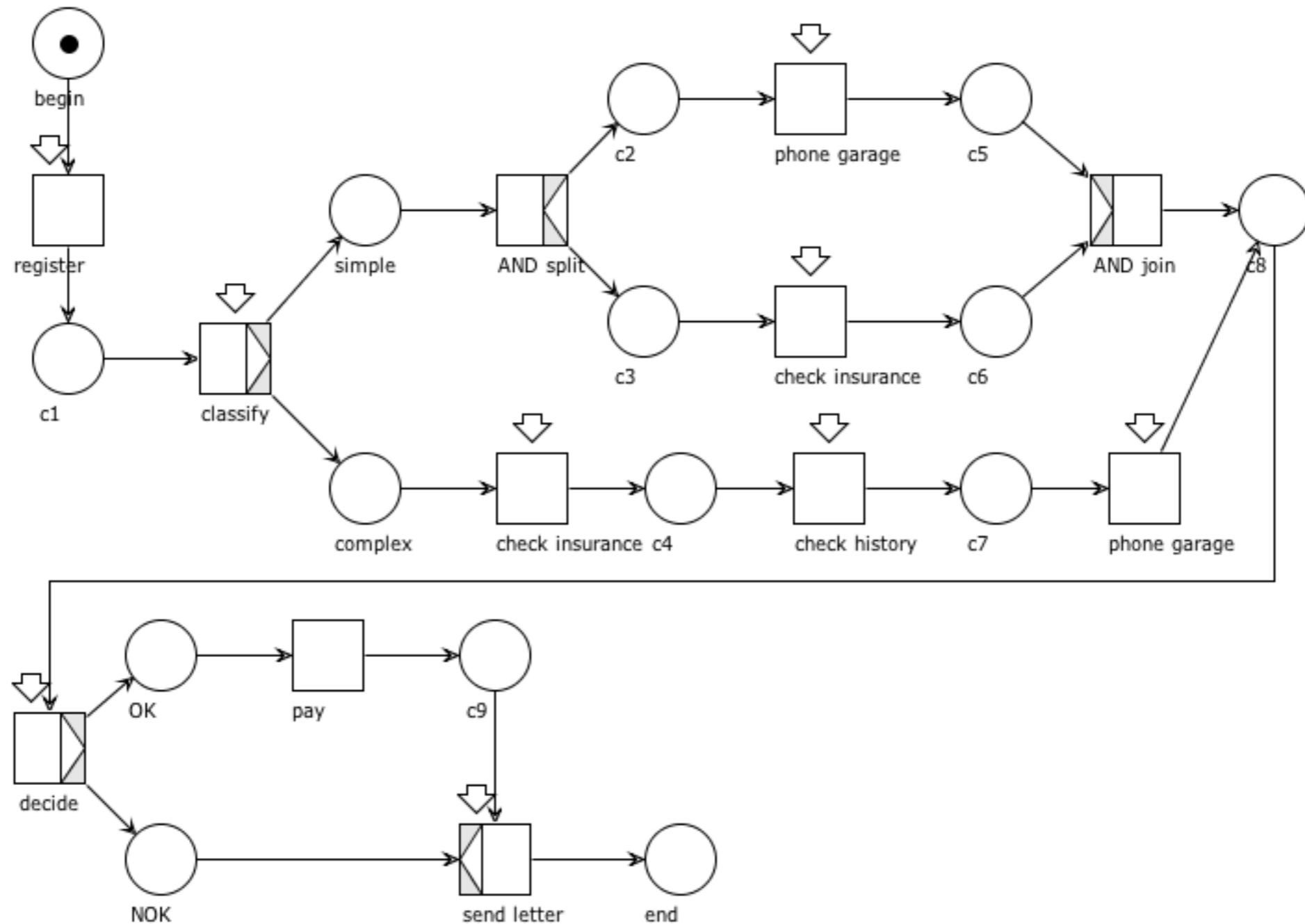

Motivation for the analysis

L(N) shows the correct ways to run the process
if it is empty there is clearly some problem

Are we guaranteed that nothing can go wrong?

Are all tasks necessary?

Are we guaranteed that once a case is started
it will reach an end?

BPs are large, with increasing complexity
flawed situations are frequent

Is this WF net ok?

What does it mean
"to be ok"?

