

Business Processes Modelling

MPB (6 cfu, 295AA)

Roberto Bruni

<http://www.di.unipi.it/~bruni>

20 - Workflow modules



Object



We study Workflow modules to model interaction between workflows

Problem

Not all tasks of a workflow net are automatic:
they can be triggered manually or by a message

they can be used to trigger other tasks

How do we represent this?

Implicit interaction

Separately developed
processes

Some activities
can **input** messages
(symbol **?**)

Some activities
can **output** messages
(symbol **!**)

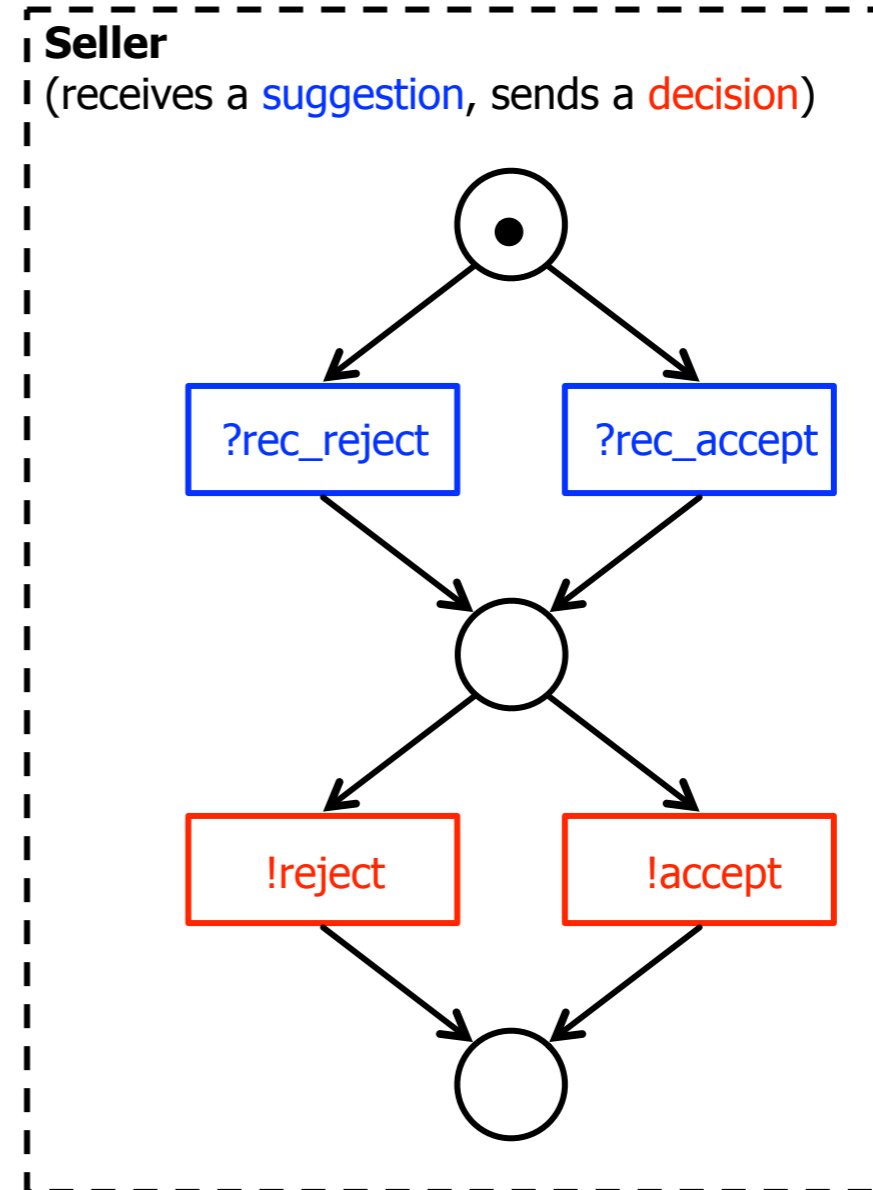

Interface

Seller has an interface for interaction

It consists of some **input** places and some **output** places

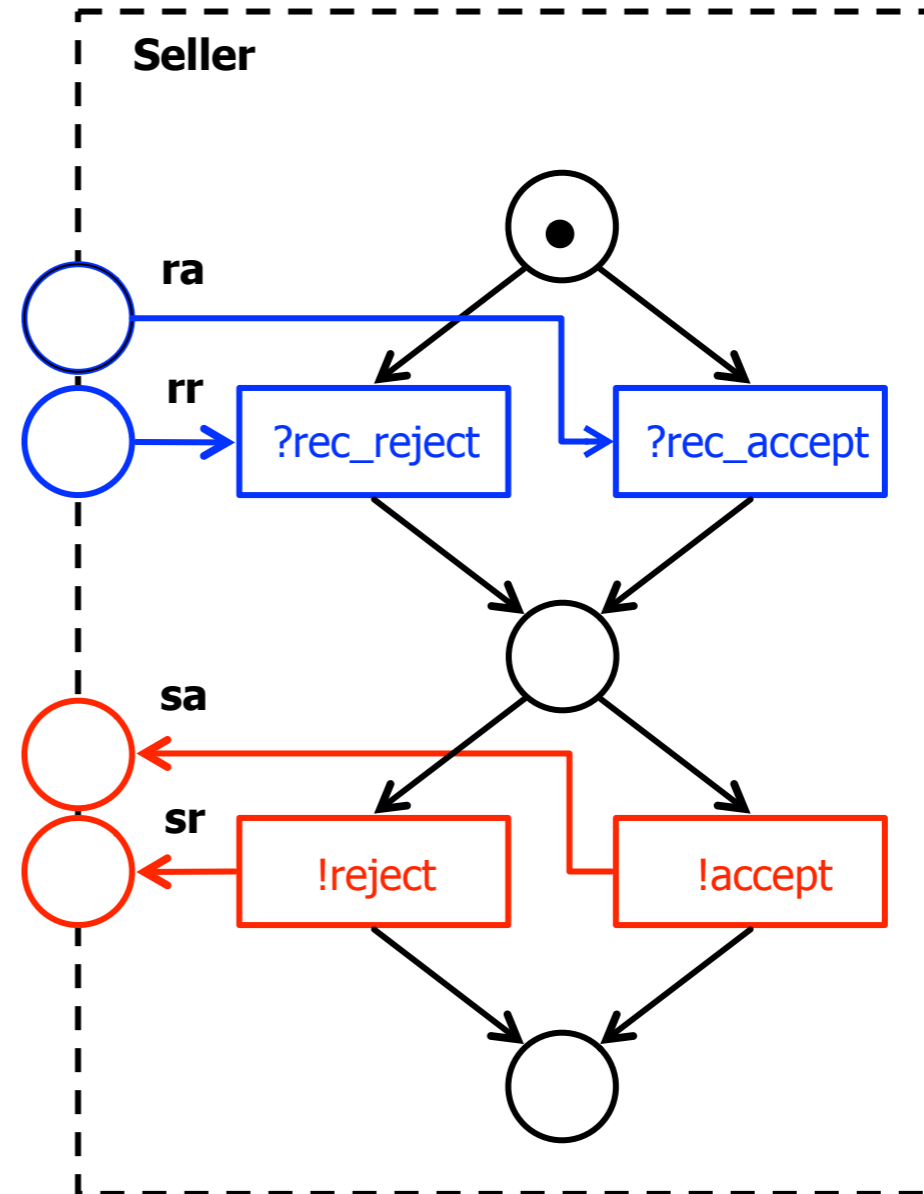

From Workflow nets to Workflow modules

Assume the original workflow net has been validated:

it is a sound (and maybe safe) workflow net

When we add the (places in the) interface

it is no longer a workflow net!

It becomes a **workflow module**

Workflow Modules

Definition: A **workflow module** consists of

a (sound) workflow net (P, T, F)

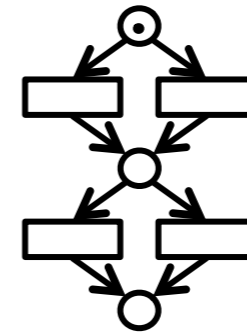

plus a set P^I of incoming places

plus a set of incoming arcs $F^I \subseteq (P^I \times T)$

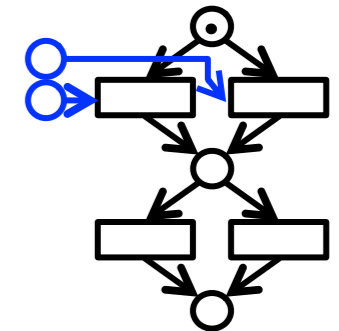

plus a set P^O of outgoing places

plus a set of outgoing arcs $F^O \subseteq (T \times P^O)$

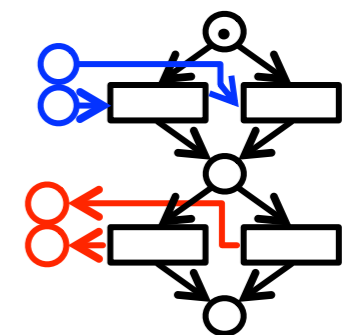

such that each transition in T has

at most one arc to places in the interface $P^I \cup P^O$

Workflow module: example

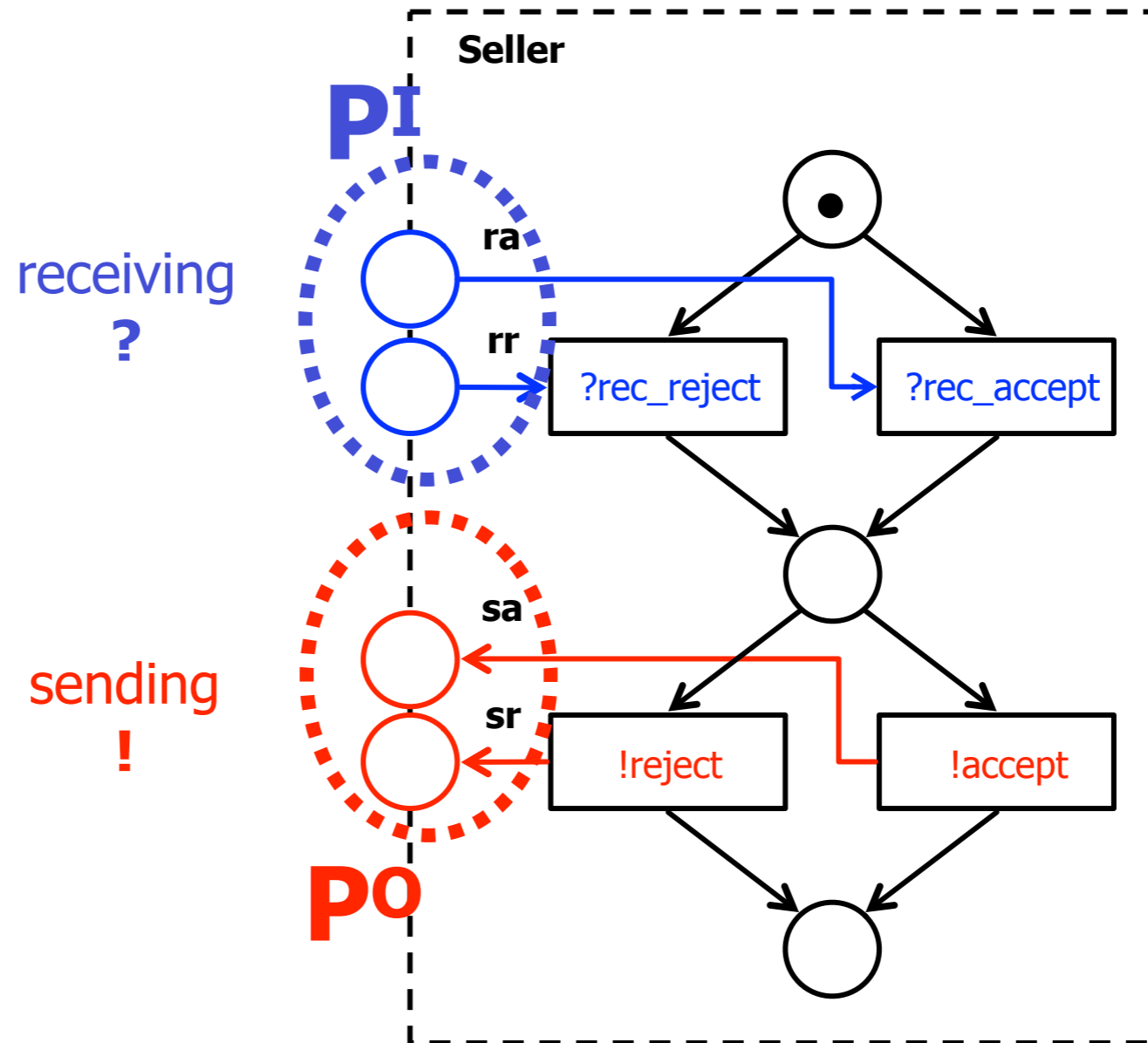

Structural compatibility

A set of workflow modules is called
structurally compatible

if

for every message that can be sent
there is exactly a module who can receive it,

and

for every message that can be received
there is exactly a module who can send it

(formats of message data are assumed to match)

Compatibility

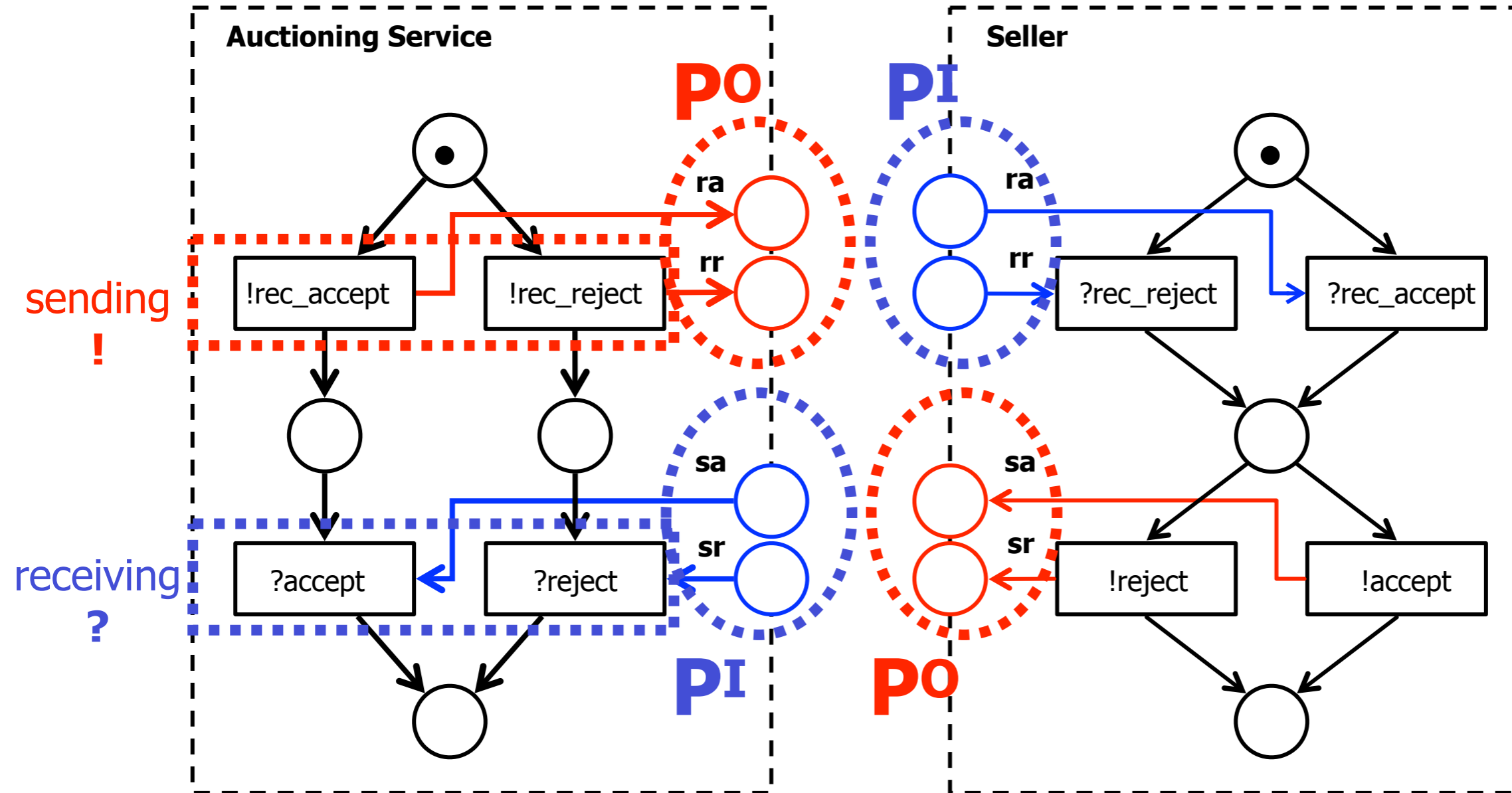

Interaction

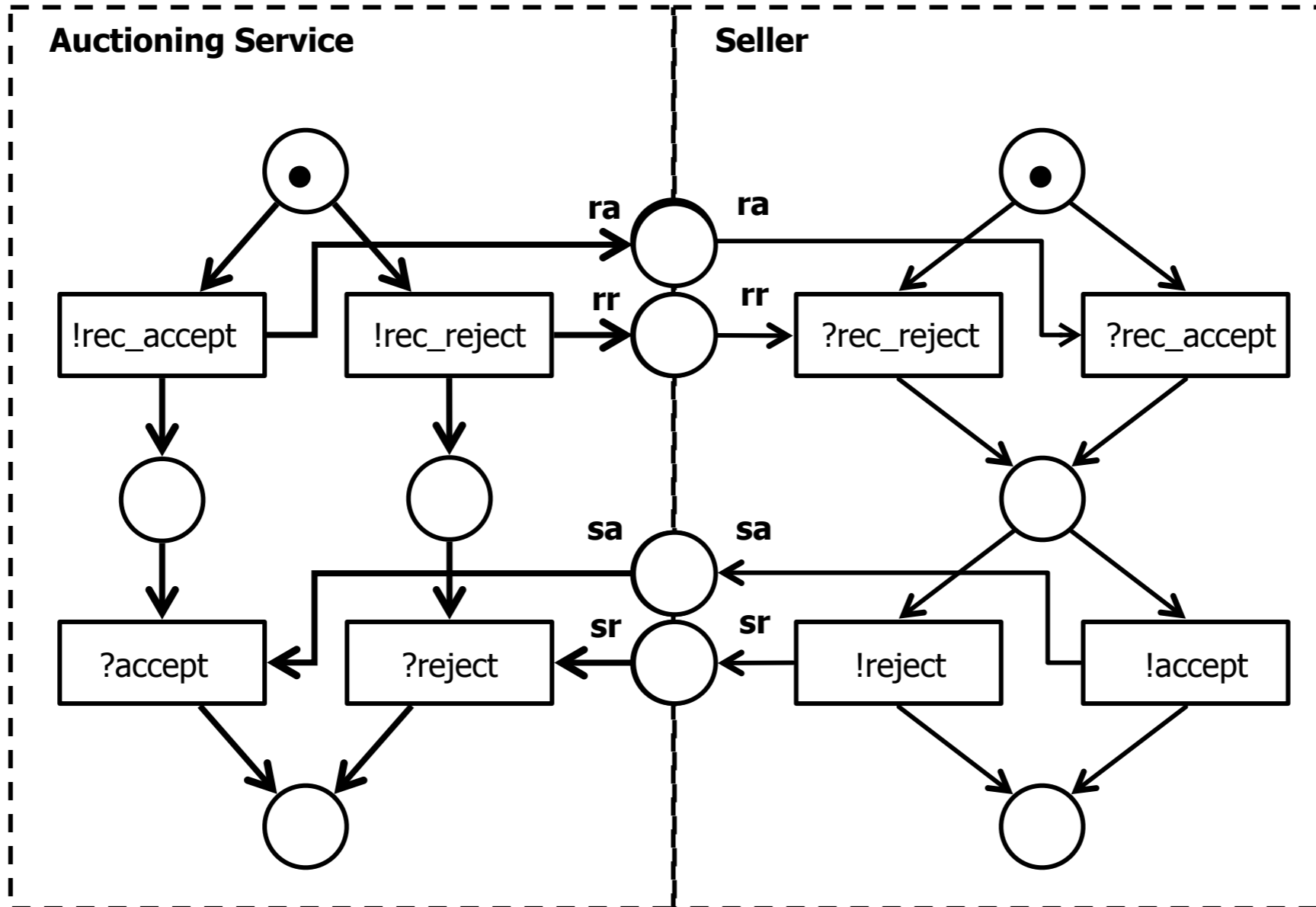

Problem

We have added places and arcs to single wf nets

We have joined places of different wf modules

How do we check that the system behaves well?

What has this check to do with WF net soundness?

Workflow systems

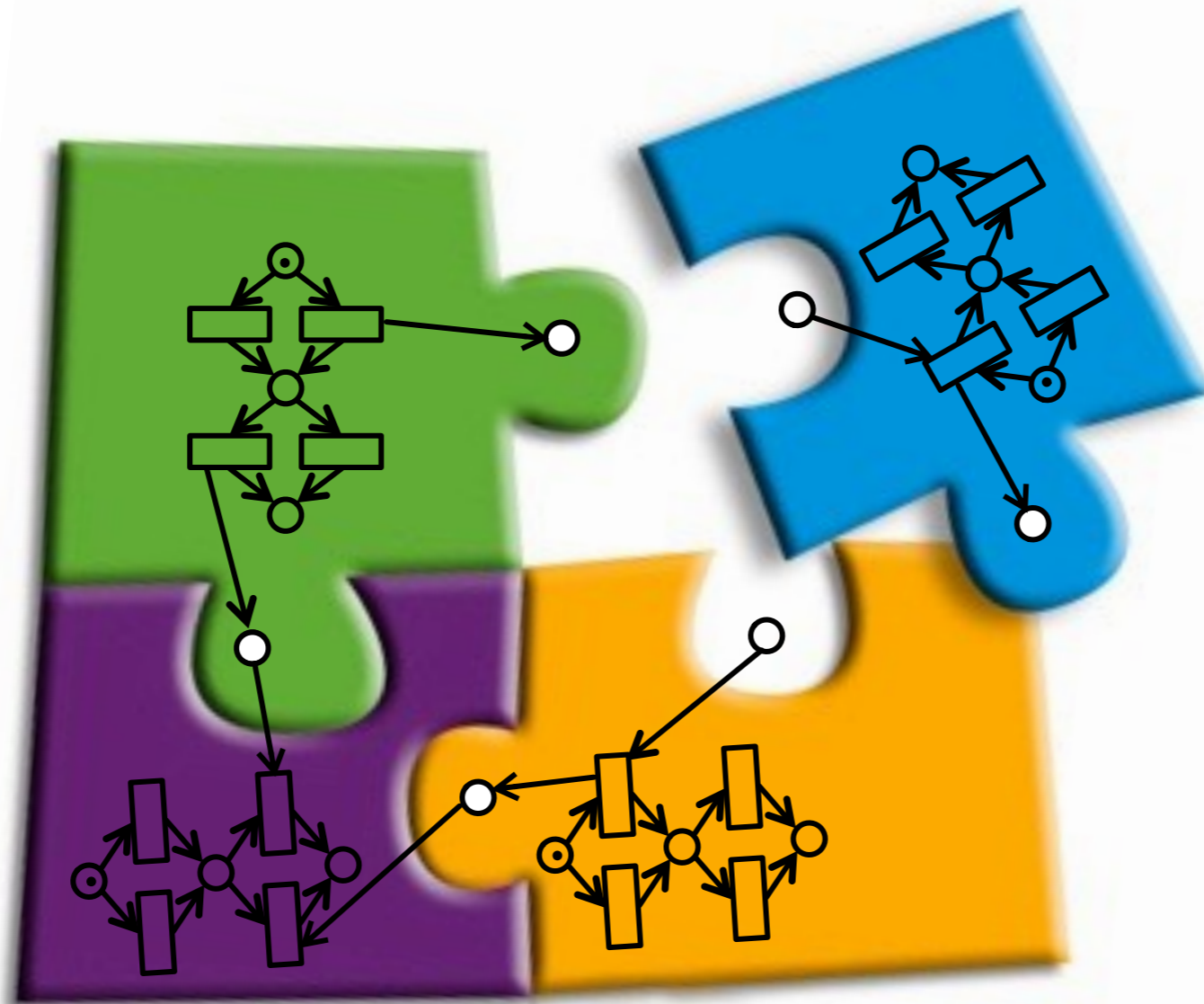

Workflow system

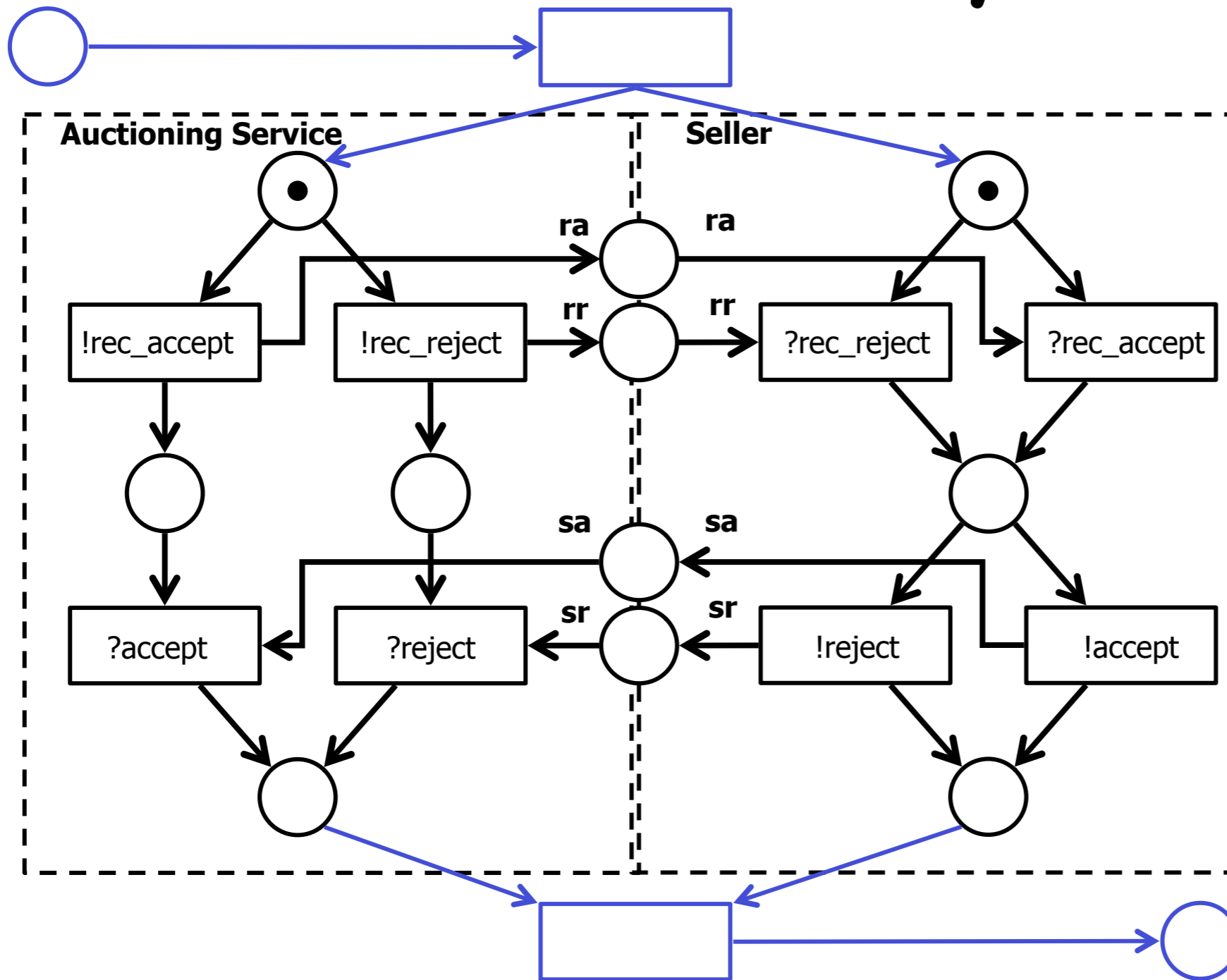

Workflow system

Definition: A **workflow system** is a wf net that consists of

a set of n structurally compatible wf modules
(initial places i_1, \dots, i_n , final places o_1, \dots, o_n)

plus an initial place i
and a transition t_i from i to i_1, \dots, i_n

plus a final place o
and a transition t_o from o_1, \dots, o_n to o

whose initial marking is i

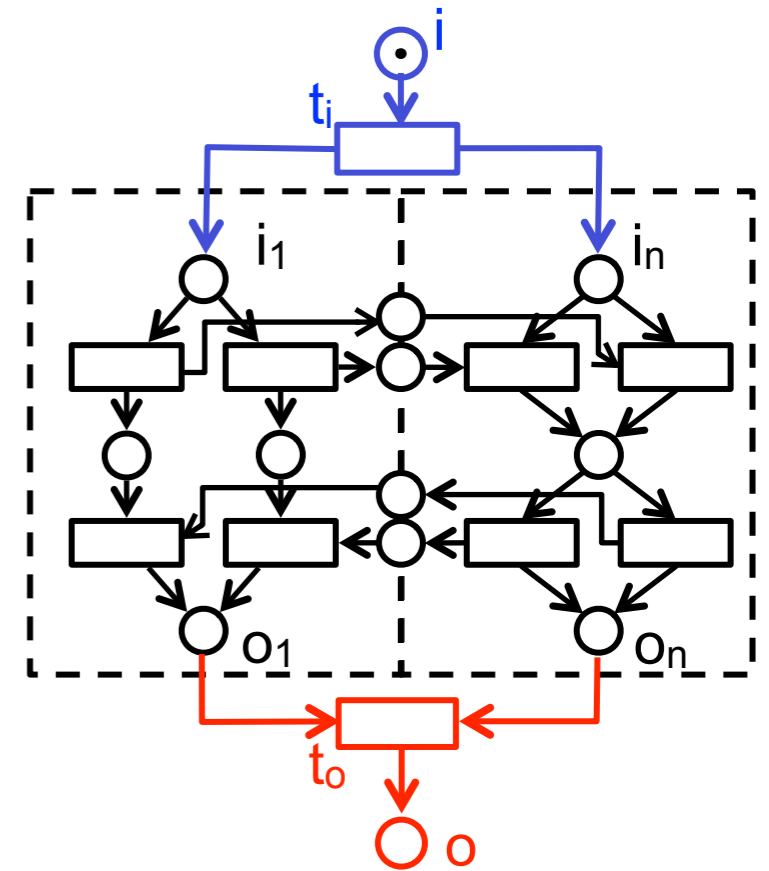

Soundness of workflow systems

A workflow system is just an ordinary workflow net

We can check its **soundness** as usual

Example

Is the wf system sound?

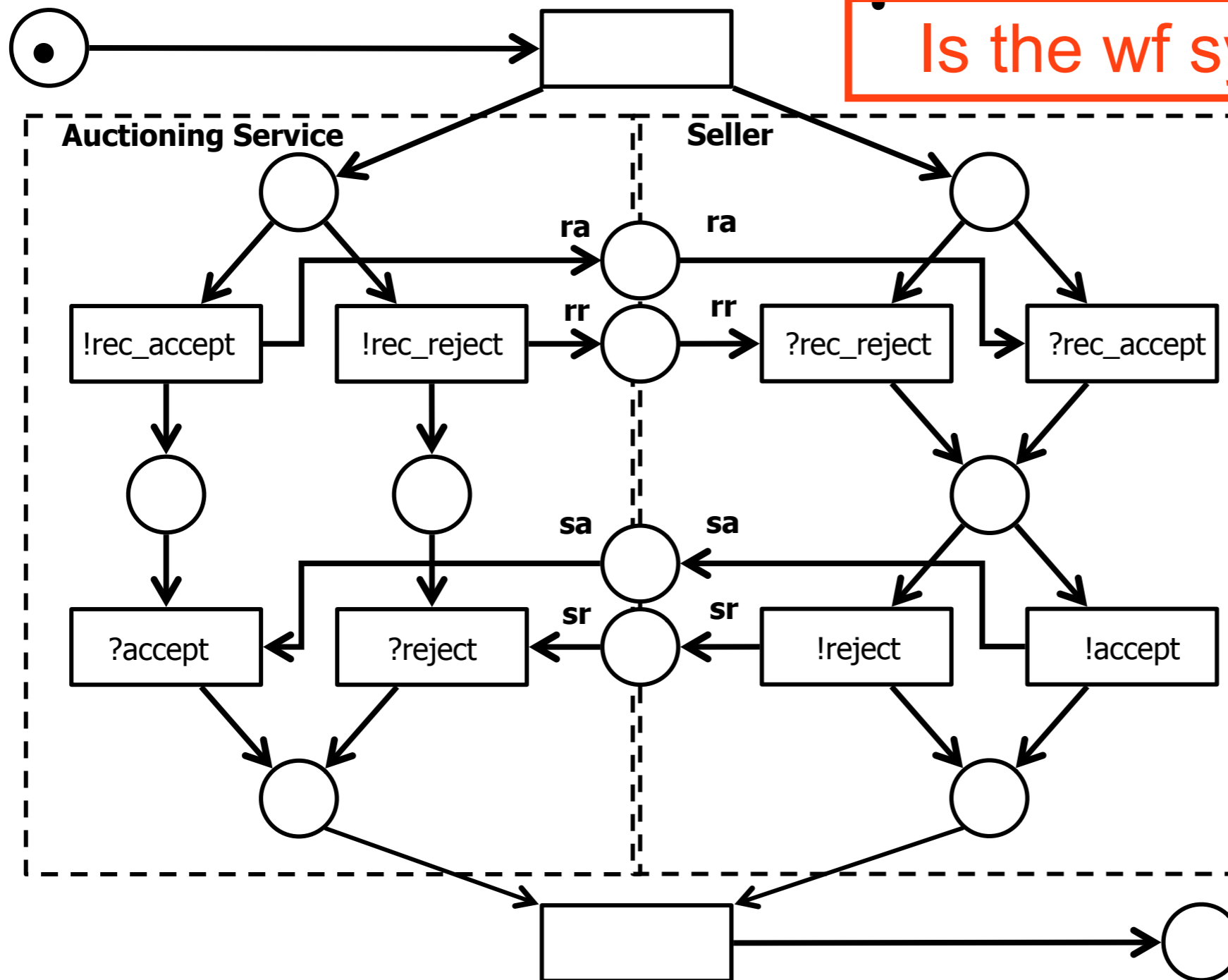

Example

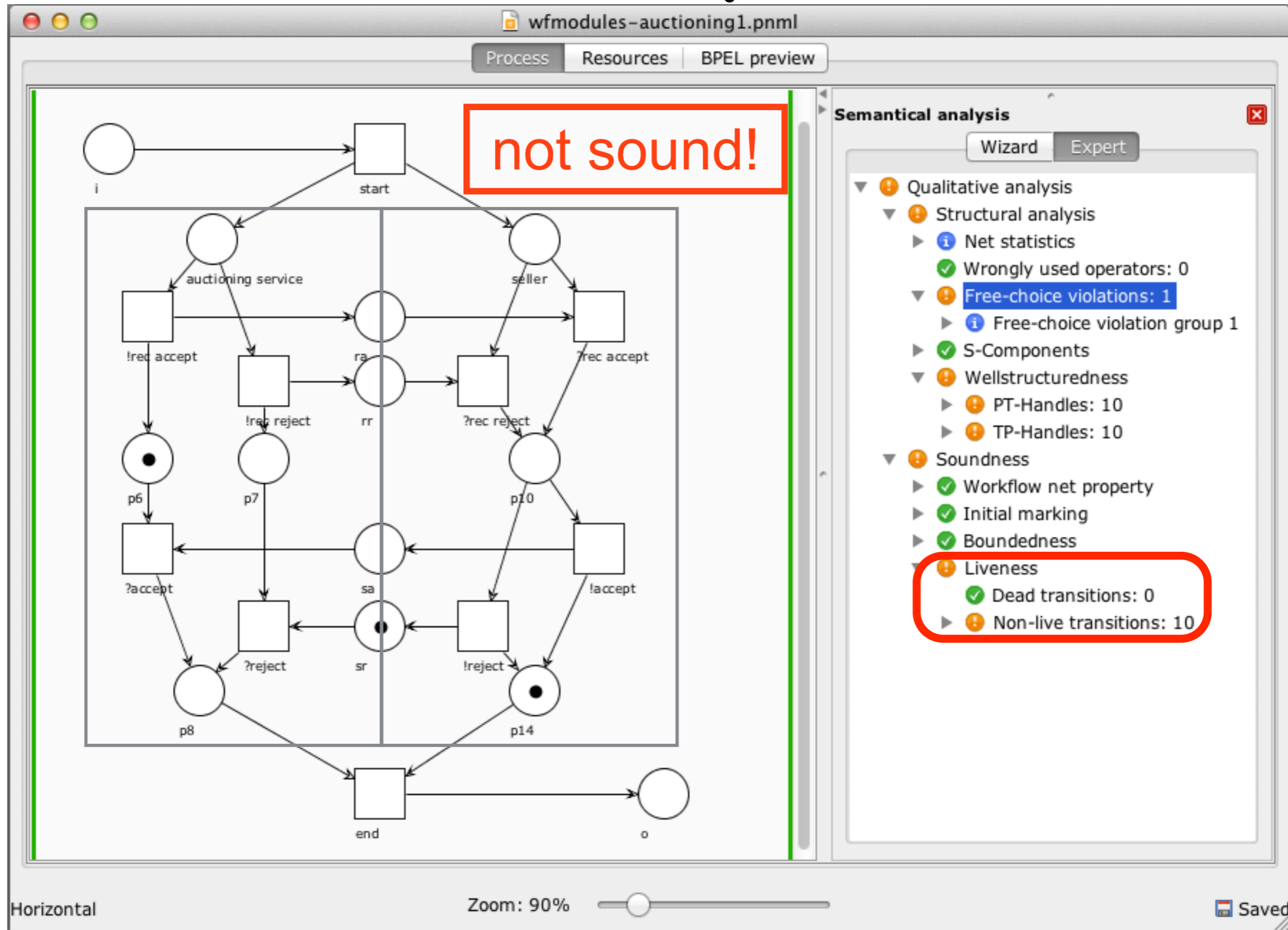

Example

Is the wf system sound?

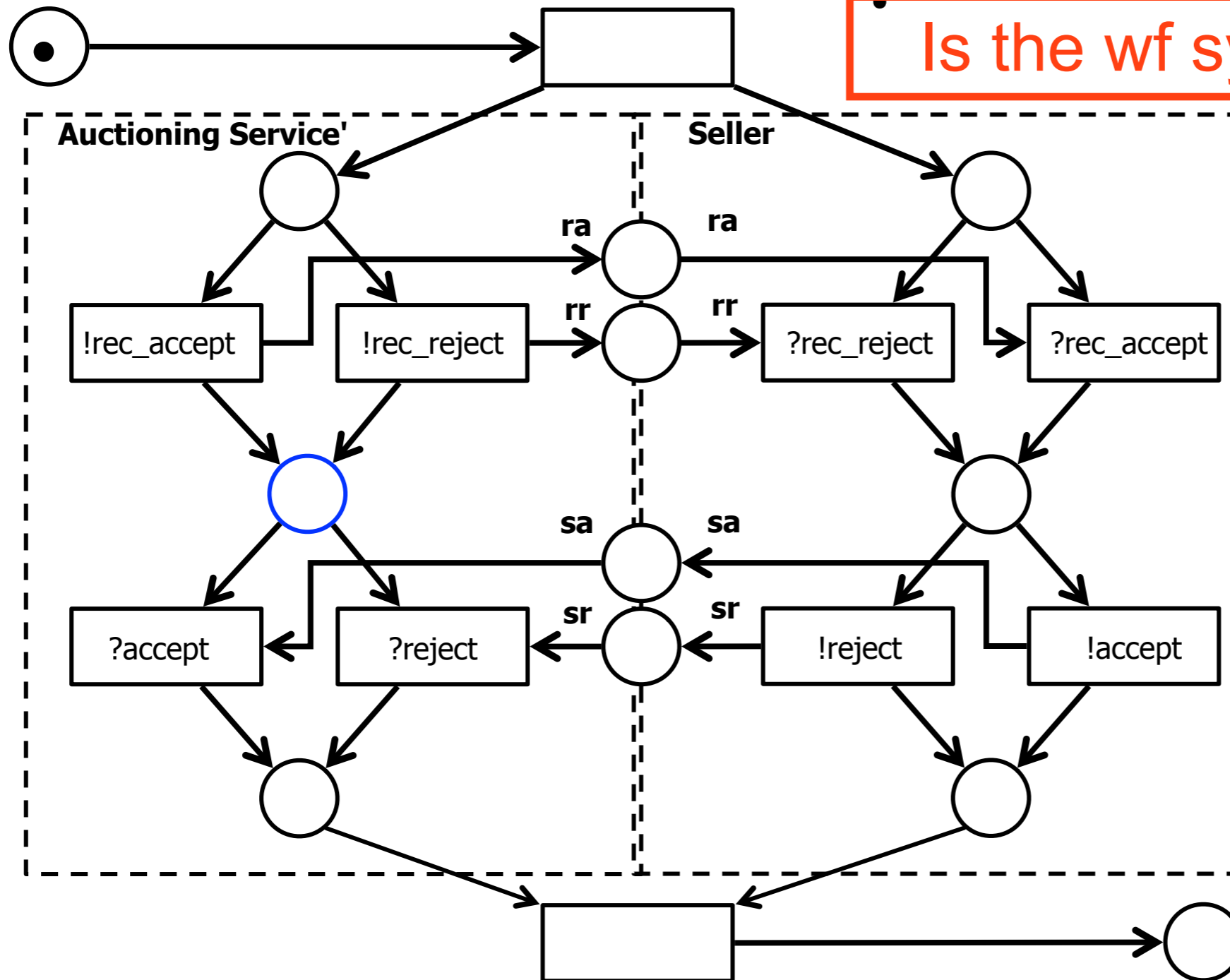

Example

wfmodules-auctioning2.pnml

Process Resources BPEL preview

sound!

Semantical analysis

Wizard Expert

- Qualitative analysis
 - Structural analysis
 - Net statistics
 - Wrongly used operators: 0
 - Free-choice violations: 2
 - Free-choice violation group 1
 - Free-choice violation group 2
 - S-Components
 - Wellstructuredness
 - PT-Handles: 12
 - TP-Handles: 12
 - Soundness
 - Workflow net property
 - Initial marking
 - Boundedness
 - Liveness

Horizontal Zoom: 90%

Saved

Exercise

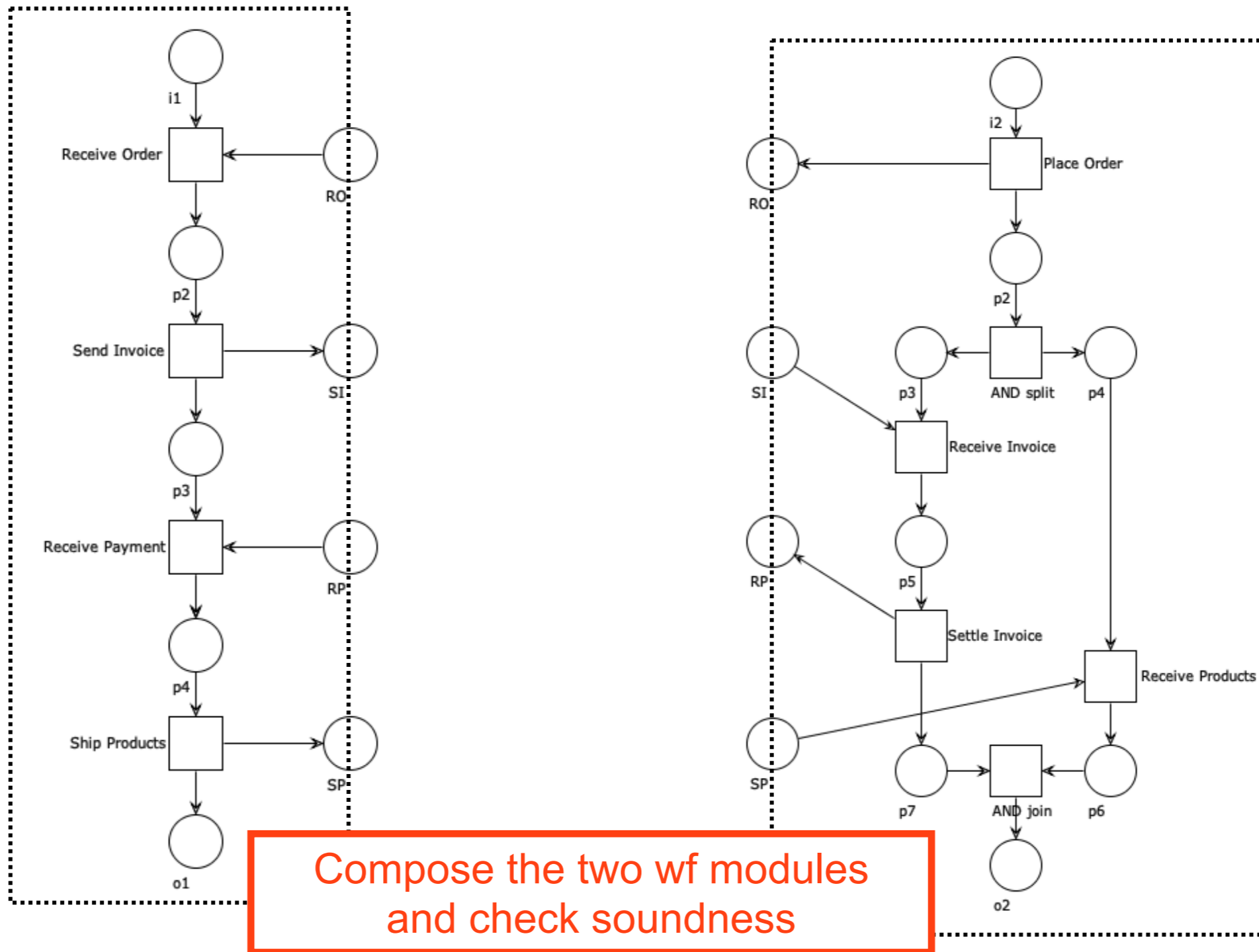

Exercise

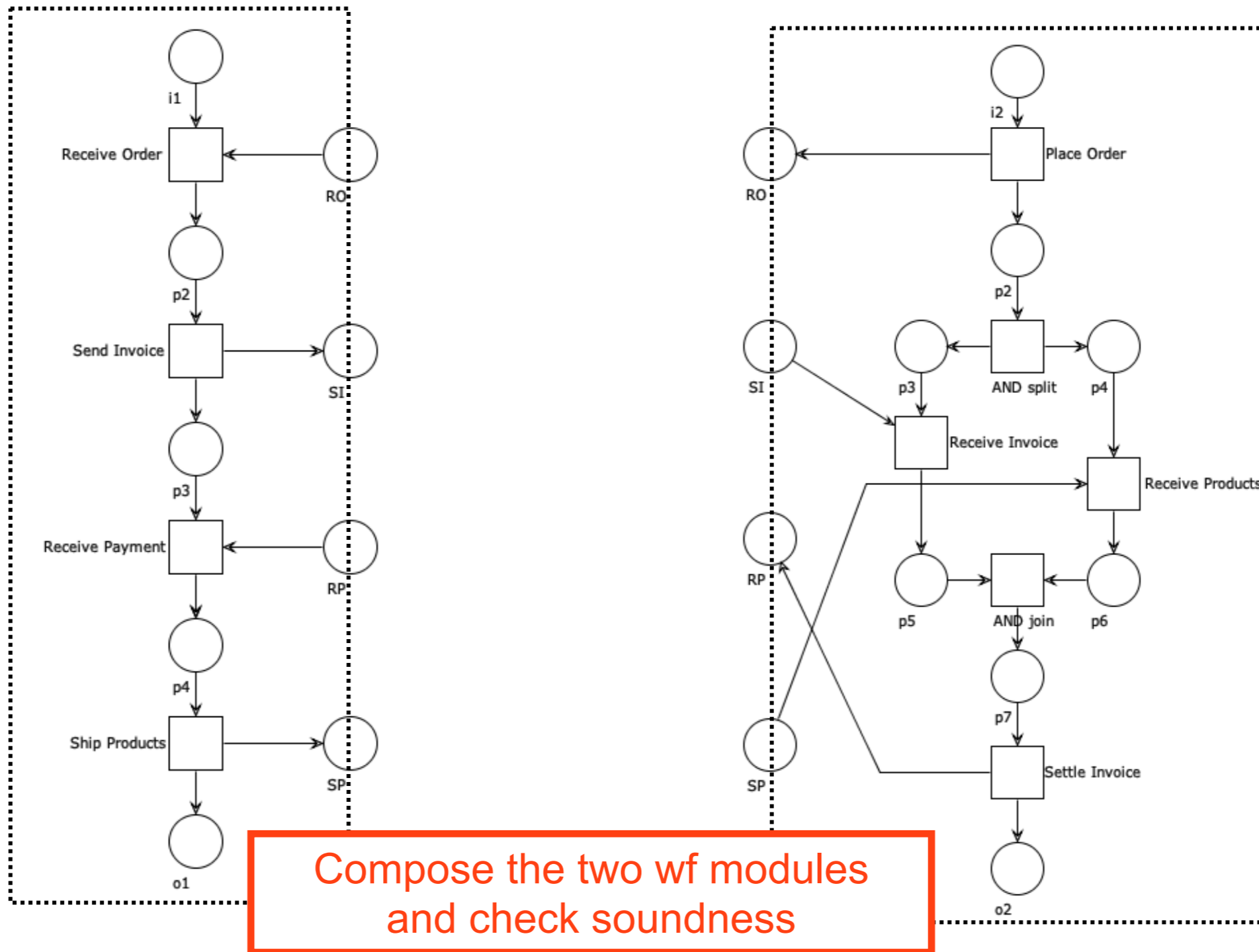

Weak soundness

Problem

When checking behavioural compatibility
the soundness of the overall net
is a too restrictive requirement

Workflow modules are designed separately,
possibly reused in several systems
It is unlikely that every functionality they offer is
involved in each system

Problem

Definition: A workflow net is **weak sound** if it satisfies “option to complete” and “proper completion”

(dead tasks are allowed)

Weak soundness can be checked on the RG

It guarantees deadlock freedom and proper termination of all modules

Sound + Sound = ?

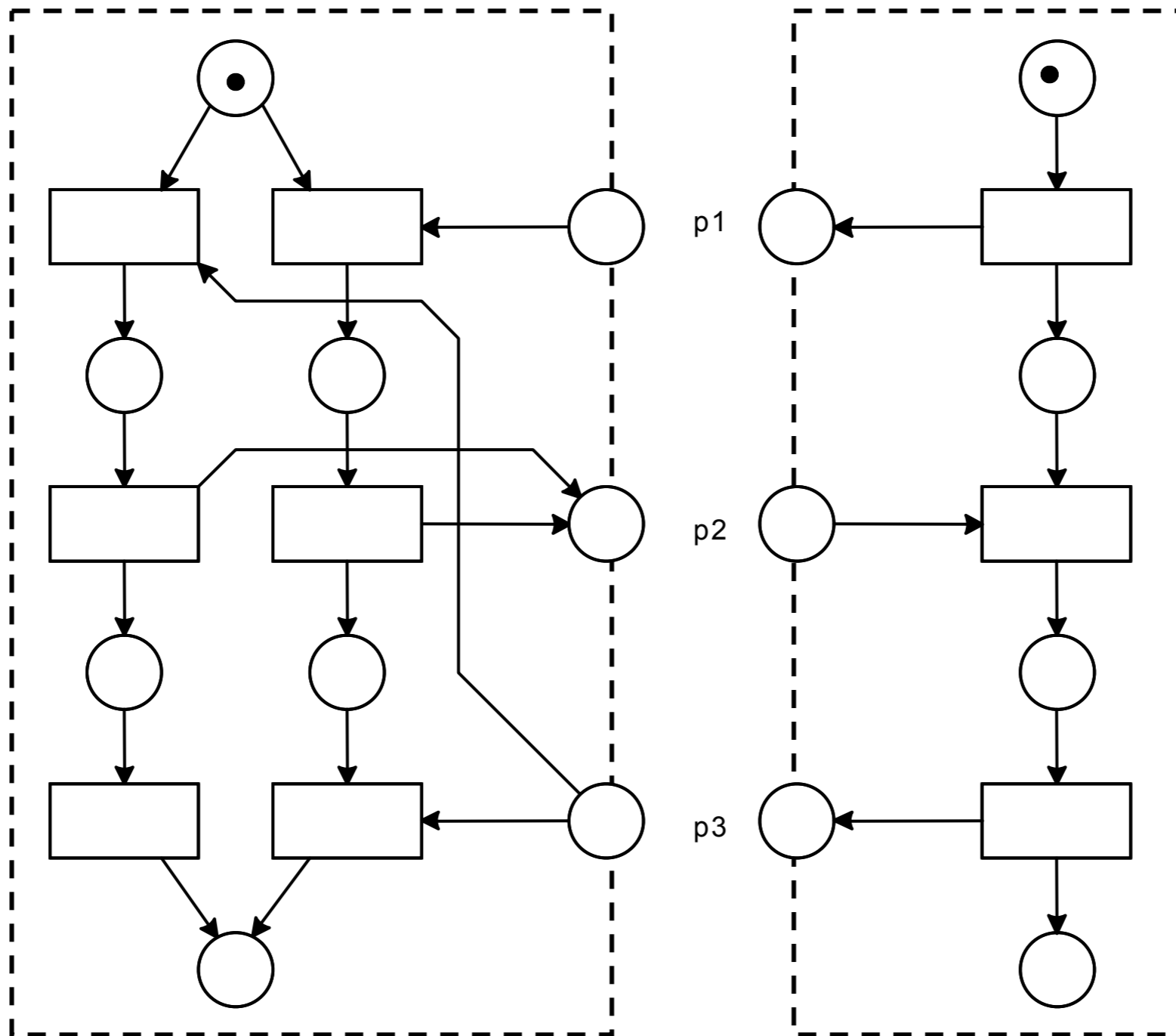

Sound + Sound = not sound

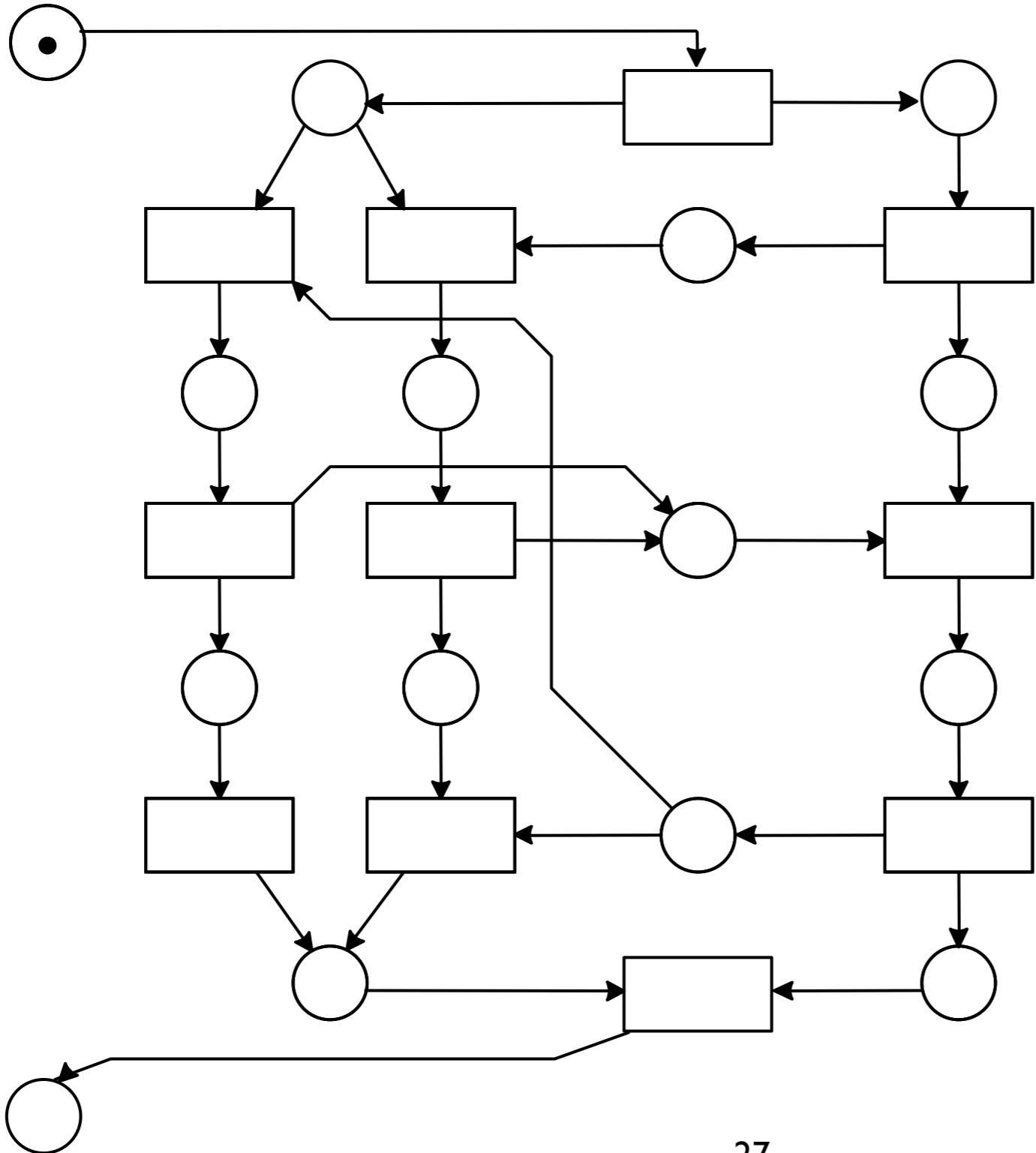

Sound + Sound = not sound

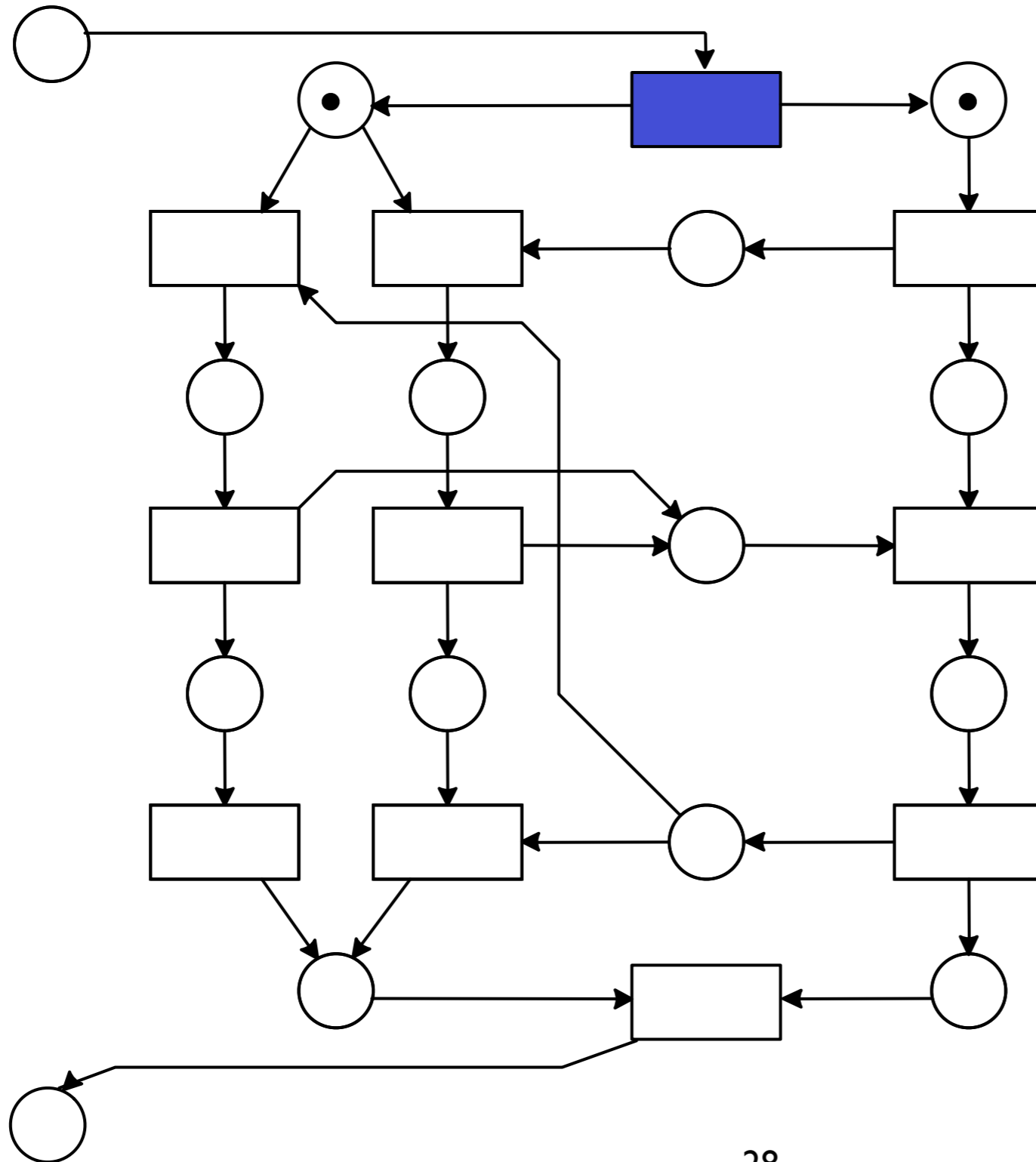

Sound + Sound = not sound

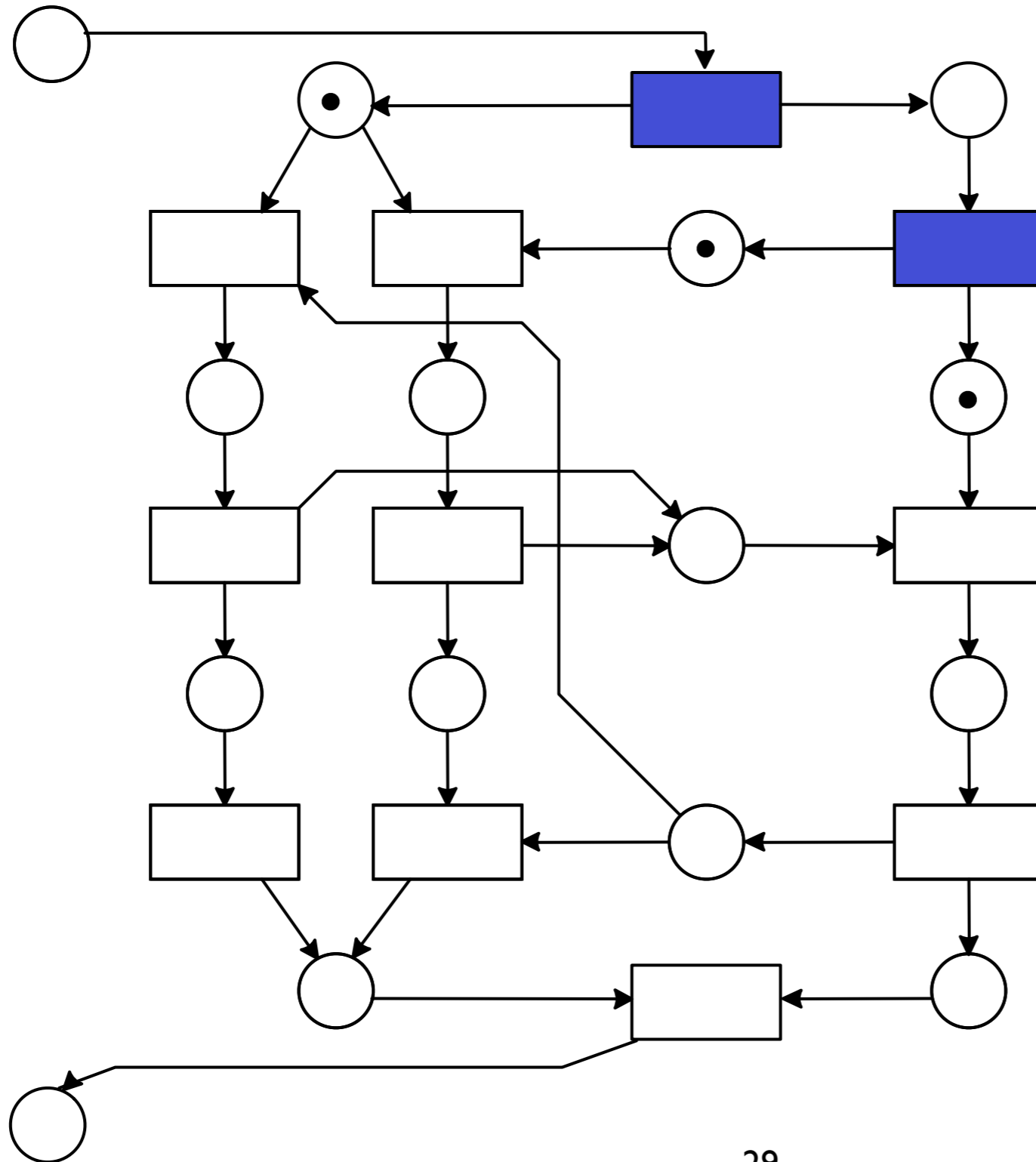

Sound + Sound = not sound

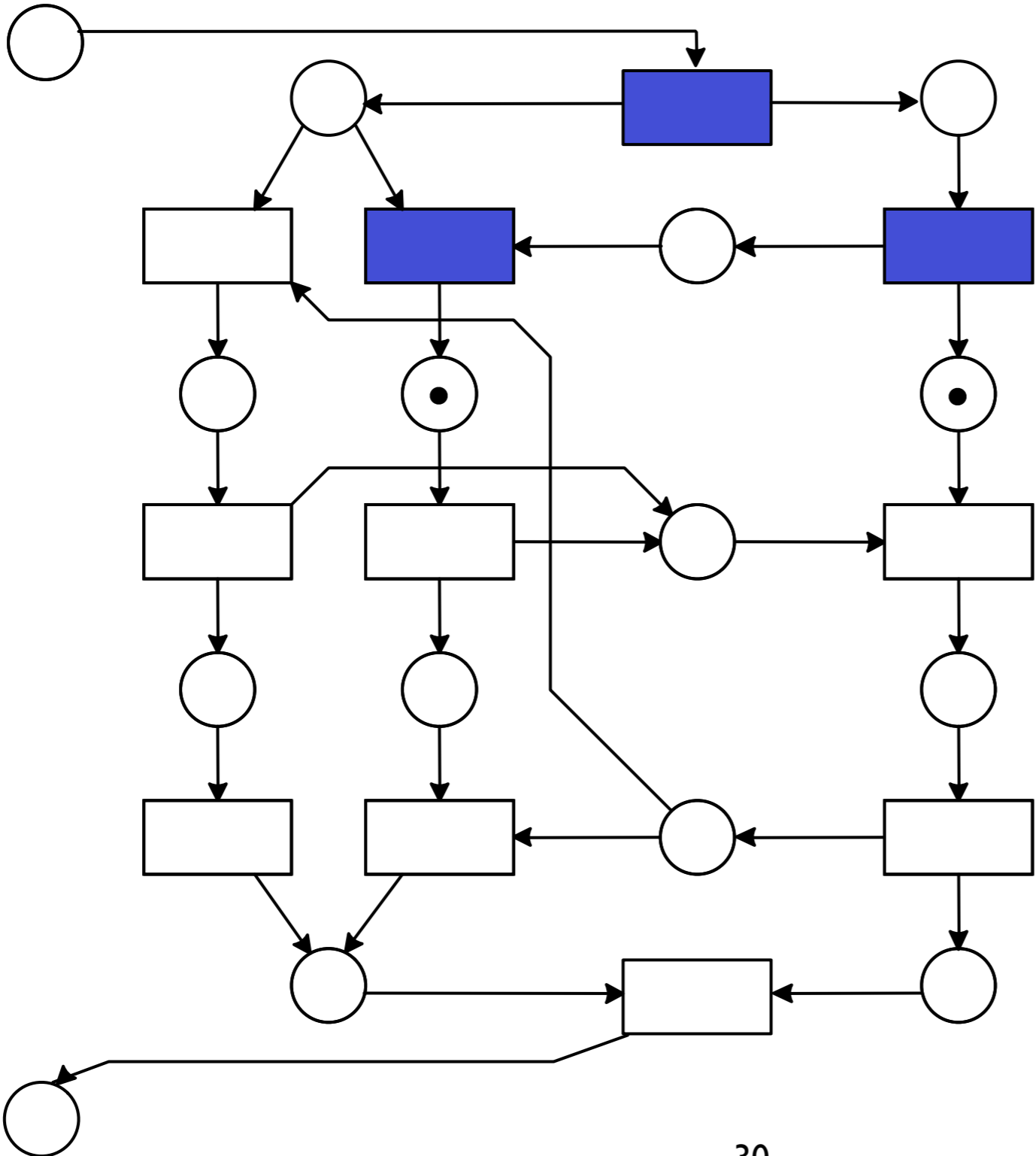

Sound + Sound = not sound

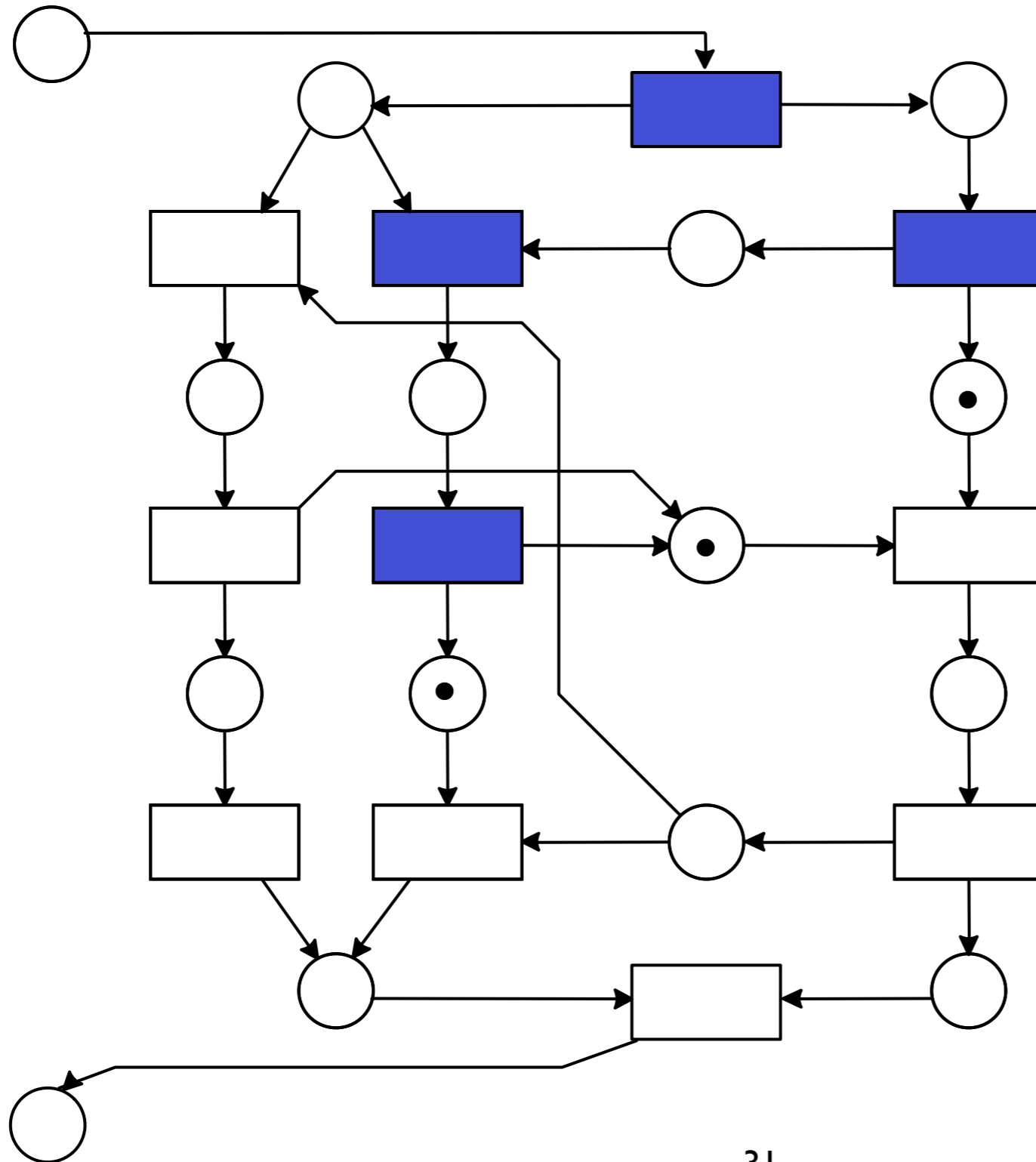

Sound + Sound = not sound

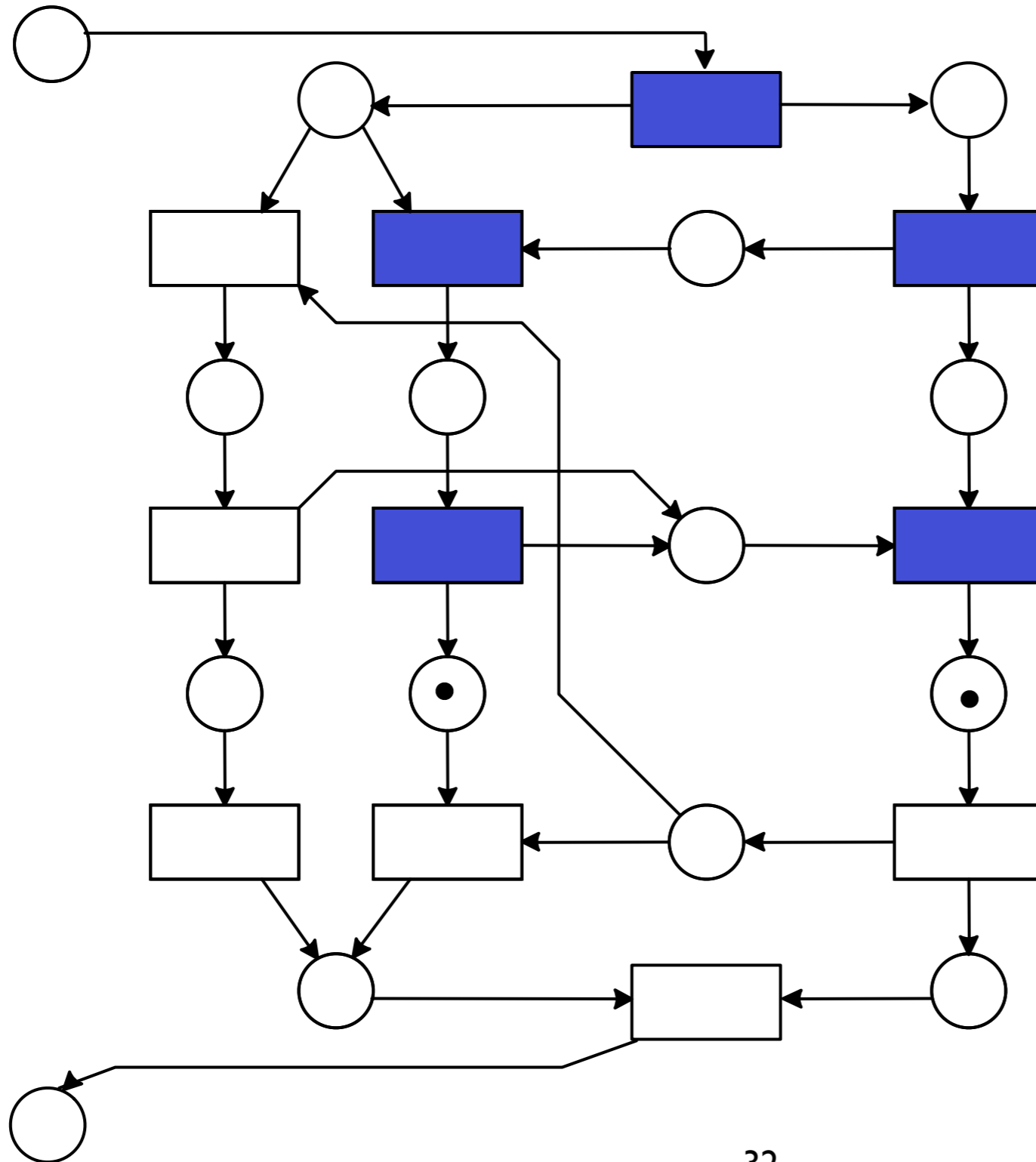

Sound + Sound = not sound

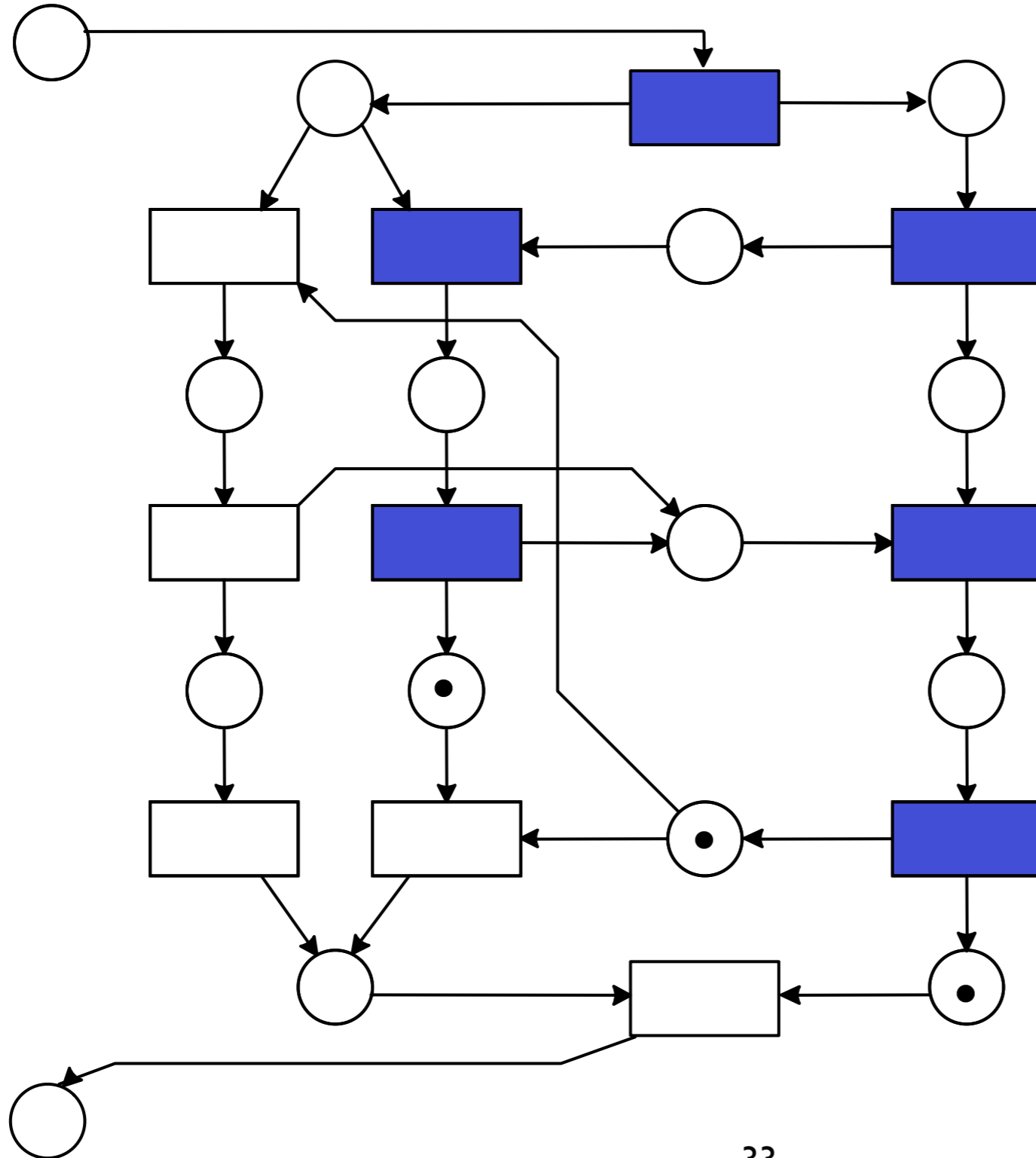

Sound + Sound = not sound

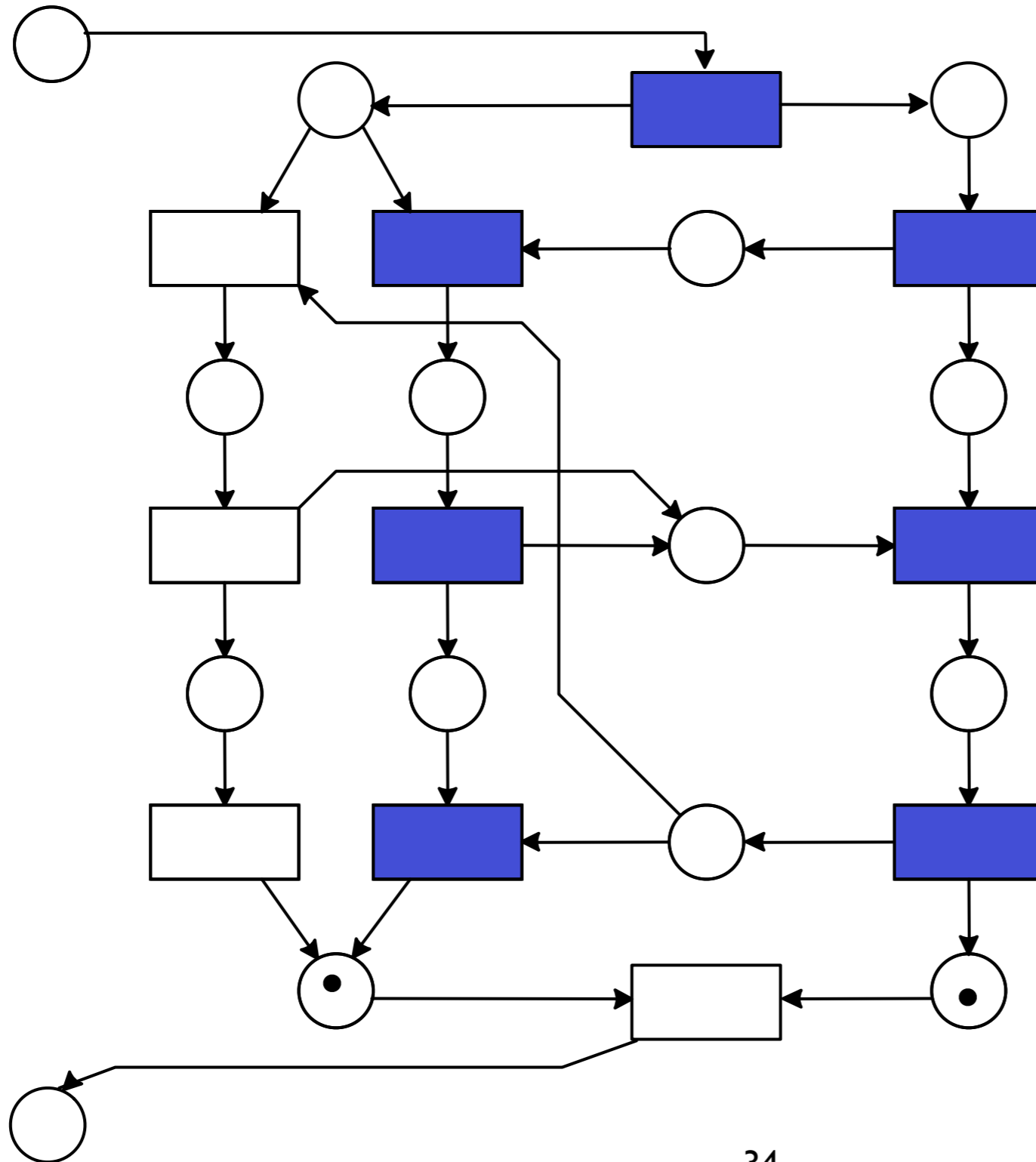

Sound + Sound = not sound

Dead
tasks!

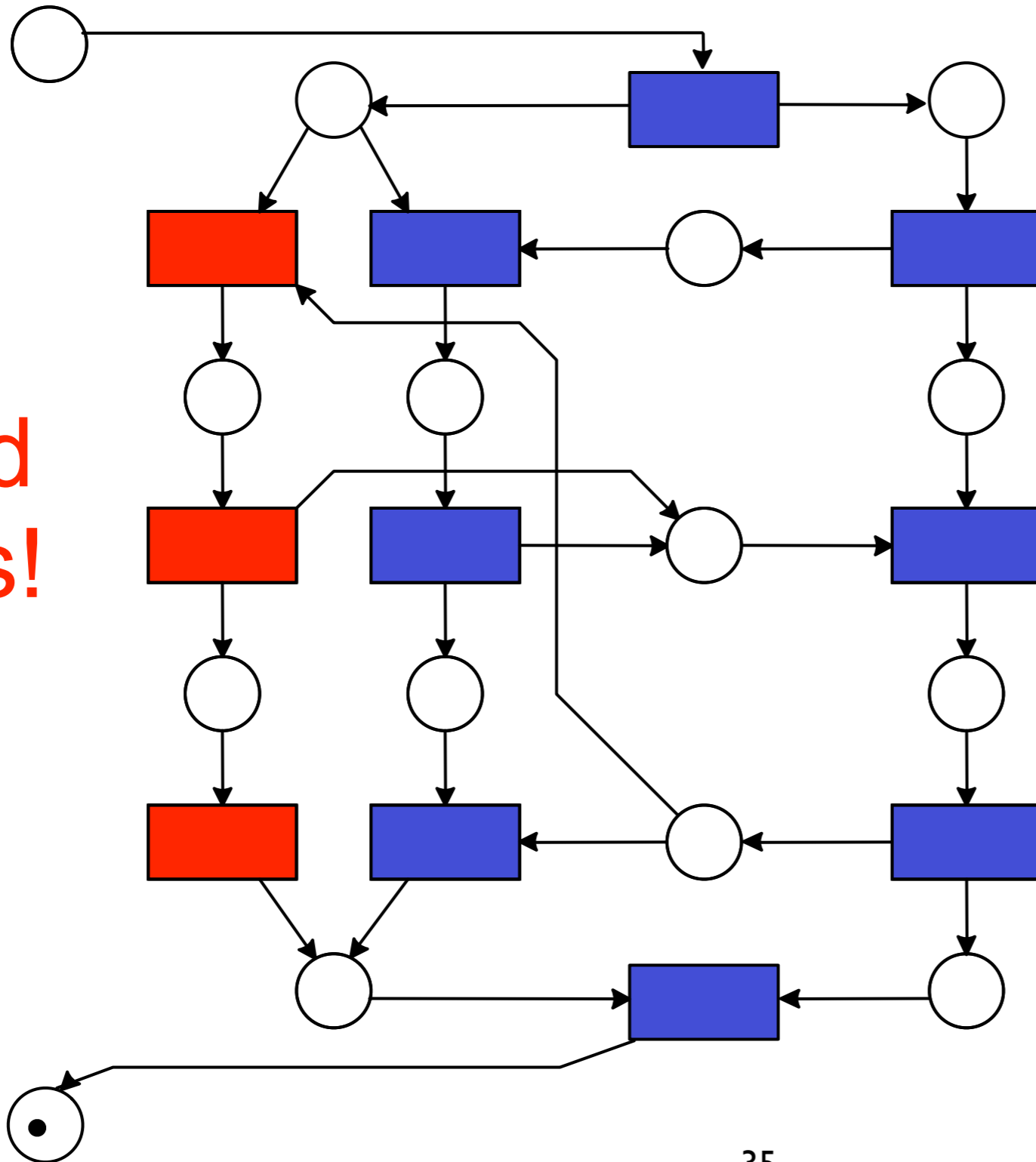

Sound + Sound = not sound

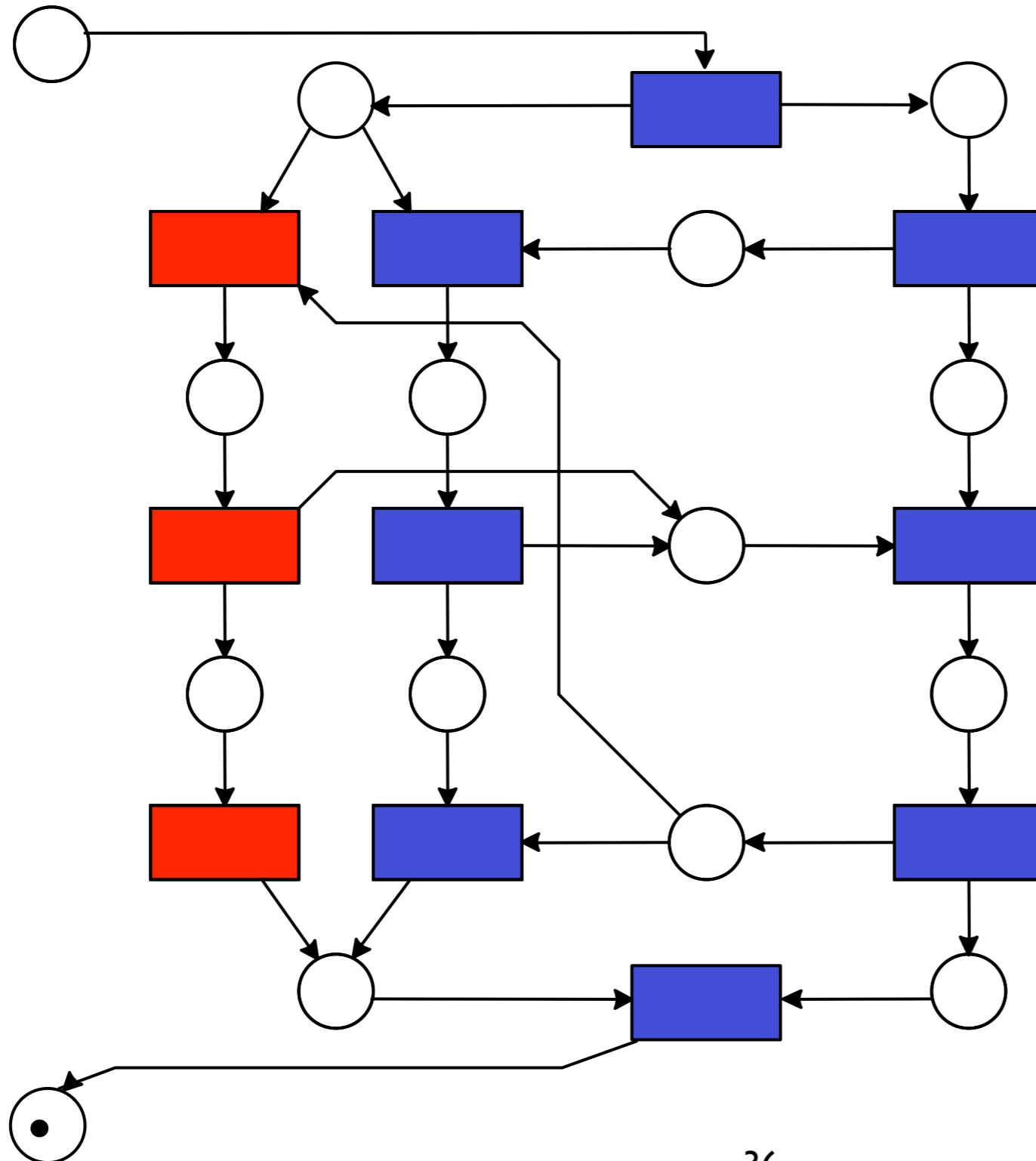

**Weak
Sound!**