

Business Processes Modelling

MPB (6 cfu, 295AA)

Roberto Bruni

<http://www.di.unipi.it/~bruni>

21 - BPMN analysis



Object

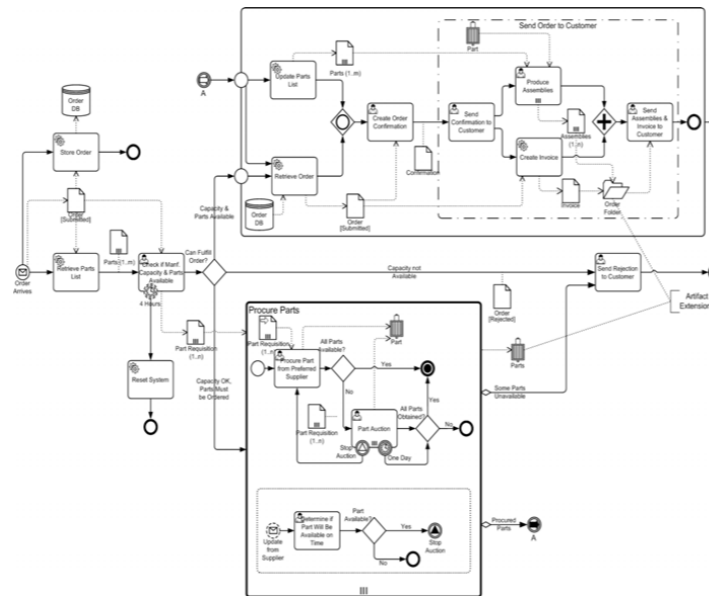

We overview the main challenges that arise when analysing BPMN diagrams with Petri nets

BPMN Diagrams

Business process diagrams

BPMN defines a standard for **Business Process Diagrams (BPD)** based on **flowcharting technique**

Four categories of elements

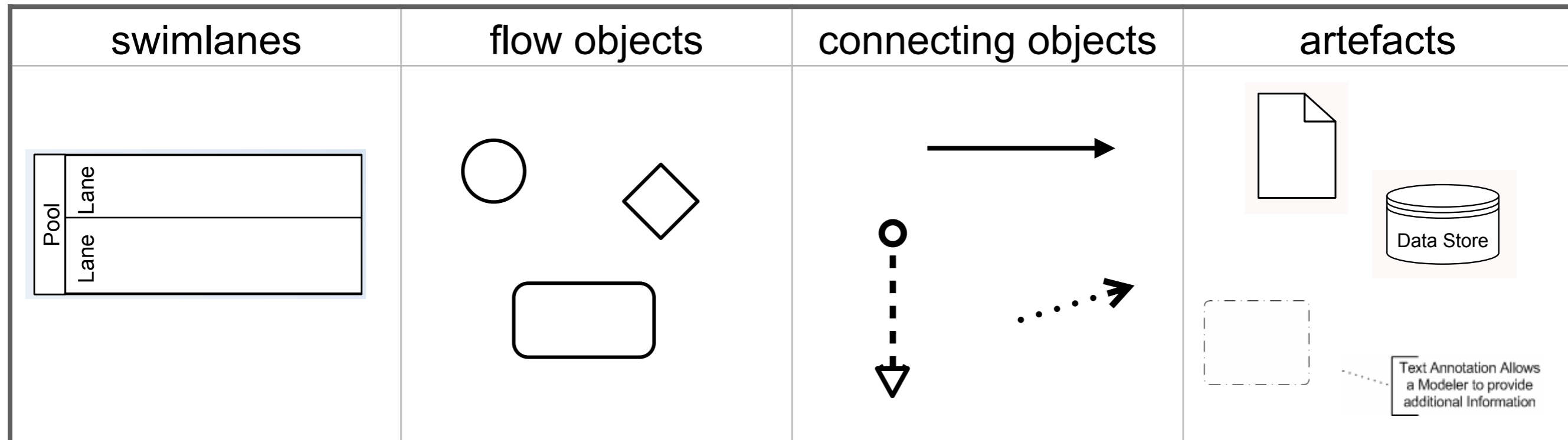

BPMN vs EPC (roughly)

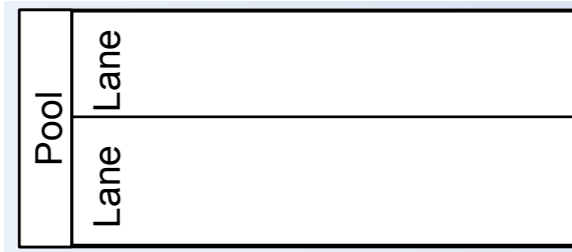

swimlanes

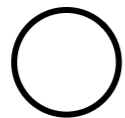

event



activity

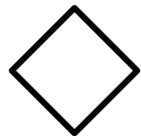

gateway



sequence flow



message flow

event



function



connector

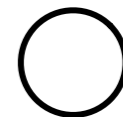

control flow



Activities

- Task**: A Task is a unit of work, the job to be performed. When marked with a **+** symbol it indicates a Sub-Process, an activity that can be refined.
- Transaction**: A Transaction is a set of activities that logically belong together; it might follow a specified transaction protocol.
- Event Sub-Process**: An Event Sub-Process is placed into a Process or Sub-Process. It is activated when its start event gets triggered and can interrupt the higher level process context or run in parallel (non-interrupting) depending on the start event.
- Call Activity**: A Call Activity is a wrapper for a globally defined Sub-Process or Task that is reused in the current process.

Activity Markers

Markers indicate execution behavior of activities:

- +** Sub-Process Marker
- ↻** Loop Marker
- |||** Parallel MI Marker
- ≡** Sequential MI Marker
- ~** Ad Hoc Marker
- ⚡** Compensation Marker

Task Types

Types specify the nature of the action to be performed:

- ✉** Send Task
- ✉** Receive Task
- 👤** User Task
- 📄** Manual Task
- 📄** Business Rule Task
- ⚙️** Service Task
- 📜** Script Task

- Sequence Flow**: defines the execution order of activities.
- Default Flow**: is the default branch to be chosen if all other conditions evaluate to false.
- Conditional Flow**: has a condition assigned that defines whether or not the flow is used.

Conversations

- Communication**: A Communication defines a set of logically related message exchanges. When marked with a **+** symbol it indicates a Sub-Conversation, a compound conversation element.
- Conversation Link**: A Conversation Link connects Communications and Participants.
- Forked Conversation Link**: A Forked Conversation Link connects Communications and multiple Participants.

Conversation Diagram

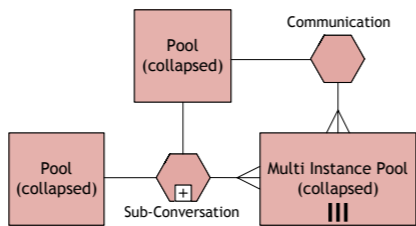

Choreographies

- Participant A**: Choreography Task
 - Participant B**: Choreography Task
 - Participant C**: Choreography Task
- A **Choreography Task** represents an Interaction (Message Exchange) between two Participants.
- Multiple Participants Marker** denotes a set of Participants of the same kind.
- A **Choreography Sub-Process** contains a refined choreography with several Interactions.

Choreography Diagram

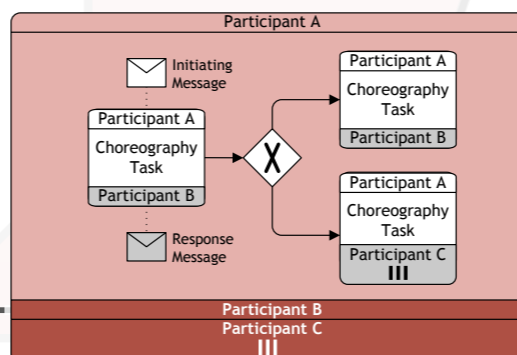

Collaboration Diagram

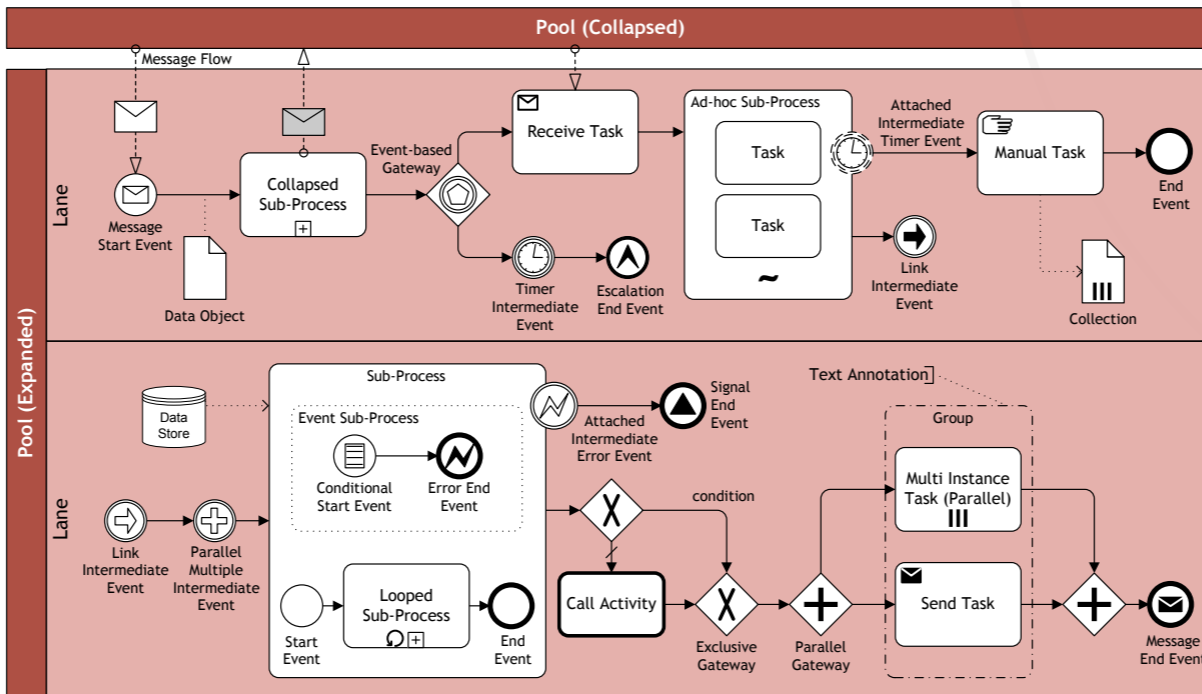

Events

	Top-Level	Start	Intermediate	End
	Event Sub-Process Interrupting	Event Sub-Process Non-interrupting	Catching	Throwing
None : Untyped events, indicate start point, state changes or final states.	○	○	○	○
Message : Receiving and sending messages.	✉	✉	✉	✉
Timer : Cyclic timer events, points in time, time spans or timeouts.	🕒	🕒	🕒	🕒
Escalation : Escalating to an higher level of responsibility.	⬆️	⬆️	⬆️	⬆️
Conditional : Reacting to changed business conditions or integrating business rules.	📄	📄	📄	📄
Link : Off-page connectors. Two corresponding link events equal a sequence flow.	↔️			➡️
Error : Catching or throwing named errors.	⚡		⚡	⚡
Cancel : Reacting to cancelled transactions or triggering cancellation.	✖️		✖️	✖️
Compensation : Handling or triggering compensation.	⏪		⏪	⏪
Signal : Signalling across different processes. A signal thrown can be caught multiple times.	📡	📡	📡	📡
Multiple : Catching one out of a set of events. Throwing all events defined	⬆️	⬆️	⬆️	⬆️
Parallel Multiple : Catching all out of a set of parallel events.	⊕	⊕	⊕	⊕
Terminate : Triggering the immediate termination of a process.	⦿			⦿

Data

- Data Input**: A Data Input is an external input for the entire process. It can be read by an activity.
- Data Output**: A Data Output is a variable available as result of the entire process.
- Data Object**: A Data Object represents information flowing through the process, such as business documents, e-mails, or letters.
- Collection Data Object**: A Collection Data Object represents a collection of information, e.g., a list of order items.
- Data Store**: A Data Store is a place where the process can read or write data, e.g., a database or a filing cabinet. It persists beyond the lifetime of the process instance.
- Message**: A Message is used to depict the contents of a communication between two Participants.

Swimlanes

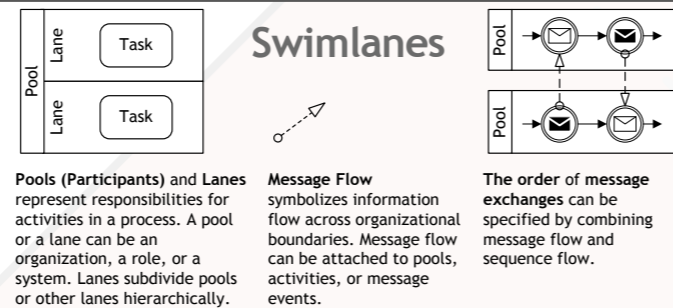

Resources as lanes: order fulfillment

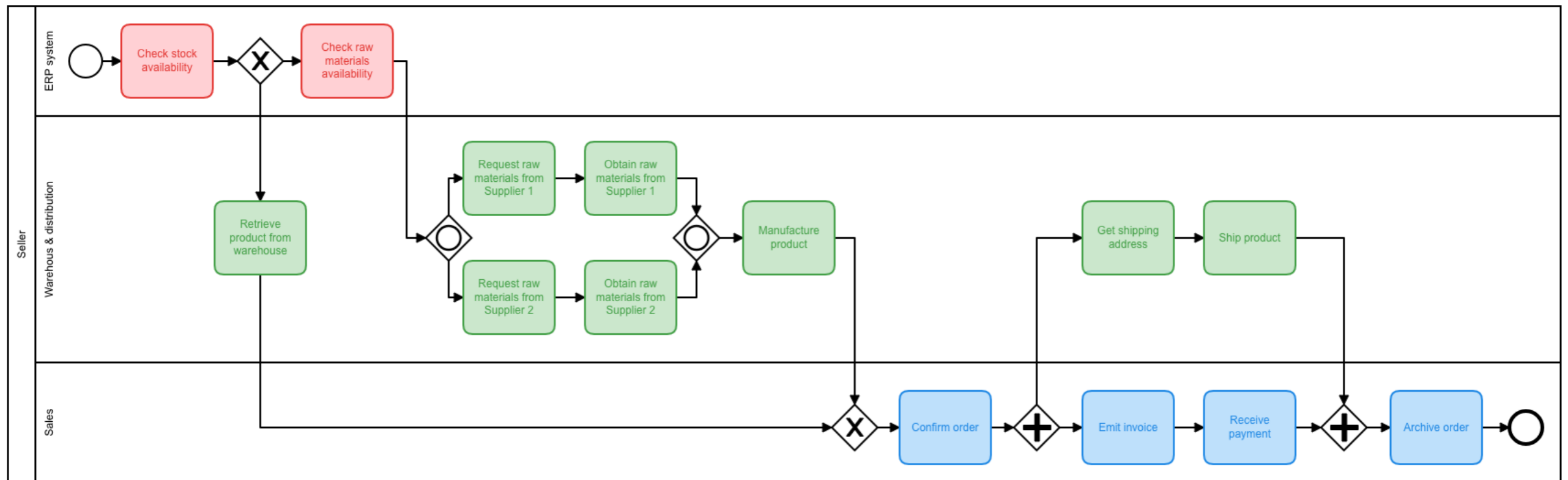

From processes to collaborations

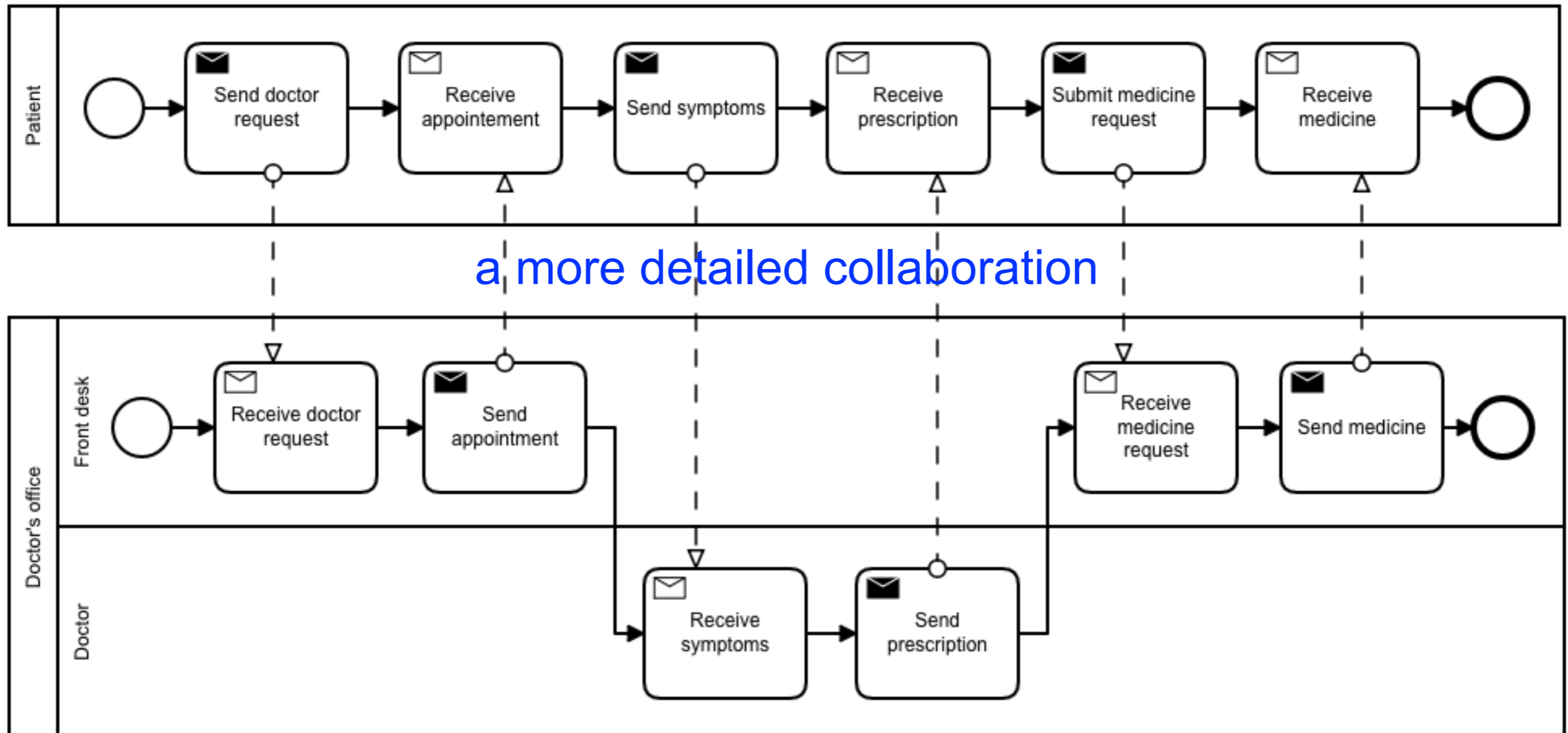

A negotiation without choice

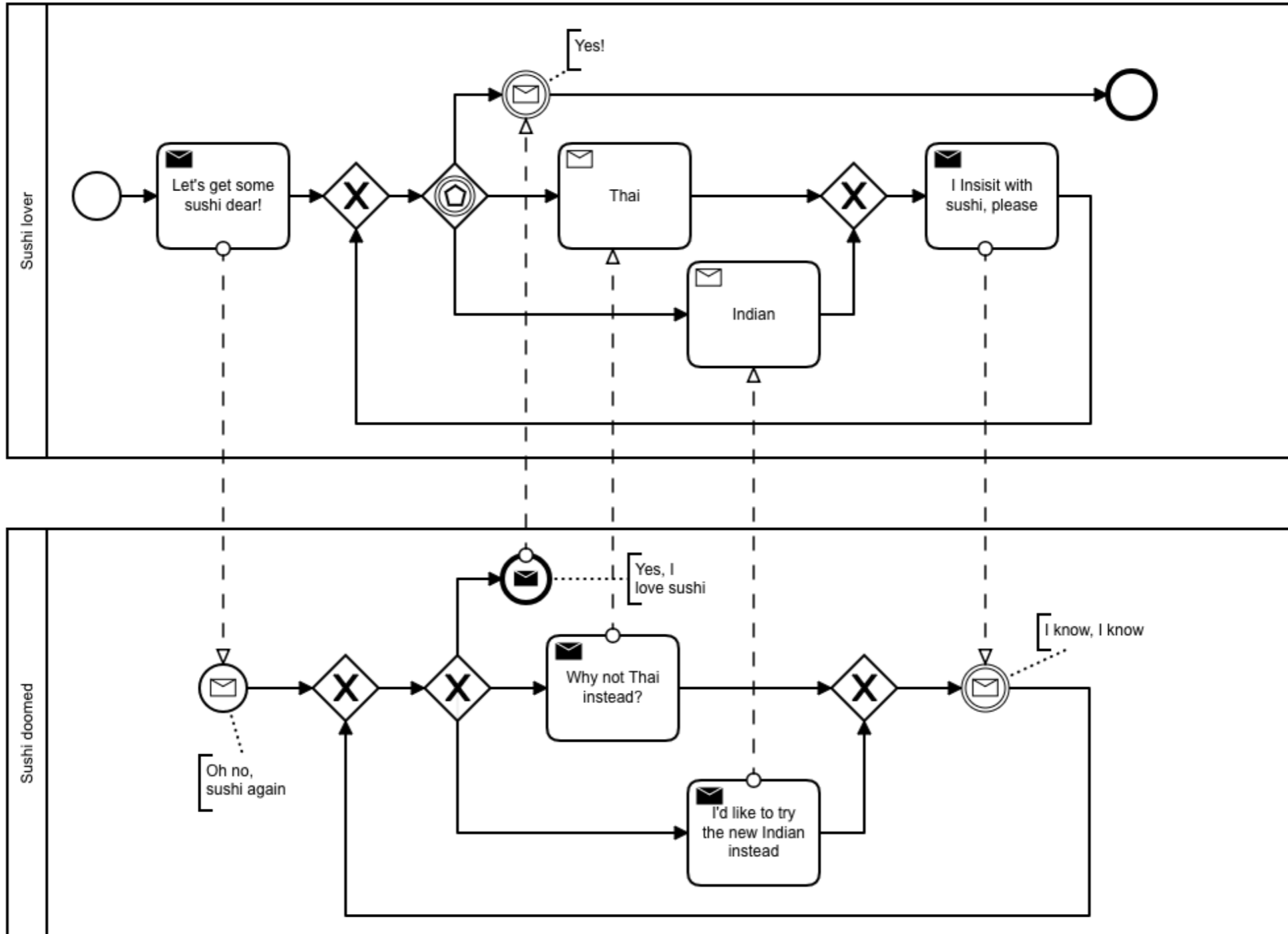

BPMN Semantics

BPMN formal semantics?

Many attempts:

Abstract State Machines (ASM)

Term Rewriting Systems

Graph Rewrite Systems

Process Algebras

Temporal Logic

...

Petri nets

(Usual difficulties with OR-join semantics)

Sound BPMN diagrams

We can exploit the formal semantics of nets
to give unambiguous semantics to
BPMN process diagrams
BPMN collaboration diagrams

We transform
BPMN process diagrams to wf nets
BPMN collaboration diagrams to wf systems

A BPMN diagram is sound if its net is so

We can reuse the verification tools
to check if the net is sound

Translation of BPMN to Petri nets

From BPMN to Petri nets



Available online at www.sciencedirect.com



Information and Software Technology 50 (2008) 1281–1294

**INFORMATION
AND
SOFTWARE
TECHNOLOGY**

www.elsevier.com/locate/infsof

Semantics and analysis of business process models in BPMN

Remco M. Dijkman^a, Marlon Dumas^{b,c}, Chun Ouyang^{c,*}

^a *Department of Technology Management, Eindhoven University of Technology, P.O. Box 513, 5600 MB, The Netherlands*

^b *Institute of Computer Science, University of Tartu, J Liivi 2, Tartu 50409, Estonia*

^c *Faculty of Information Technology, Queensland University of Technology, G.P.O. Box 2434, Brisbane, Qld 4001, Australia*

Simplified BPMN

a start / exception event has just one outgoing flow
and no incoming flow

an end event has just one incoming flow
and no outgoing flow

all activities and intermediate events have exactly
one incoming flow and one outgoing flow

all gateways have either
one incoming flow (and multiple outgoing)
or one outgoing flow (and multiple incoming)

Simplified BPMN

The previous constraints are no real limitation:

events or activities with multiple incoming flows:
insert a preceding XOR-join gateway

events or activities with multiple outgoing flows:
insert a following AND-split gateway

gateways with multiple incoming and outgoing flows:
decompose in two gateways

insert start / end events if needed

Pay attention to gateways

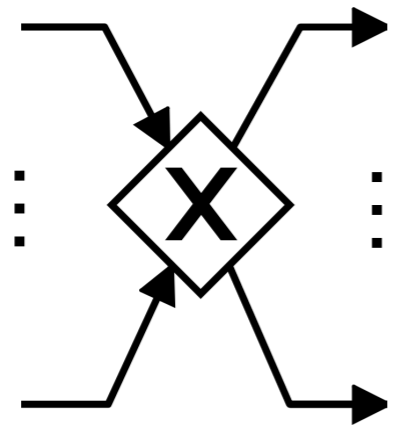

stands for

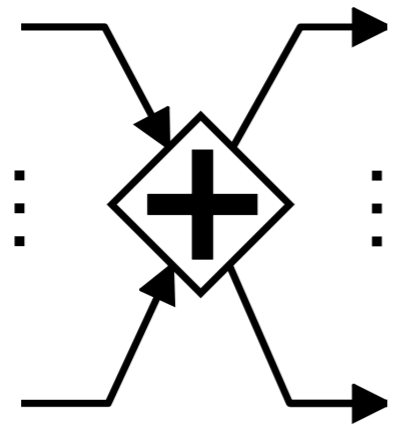
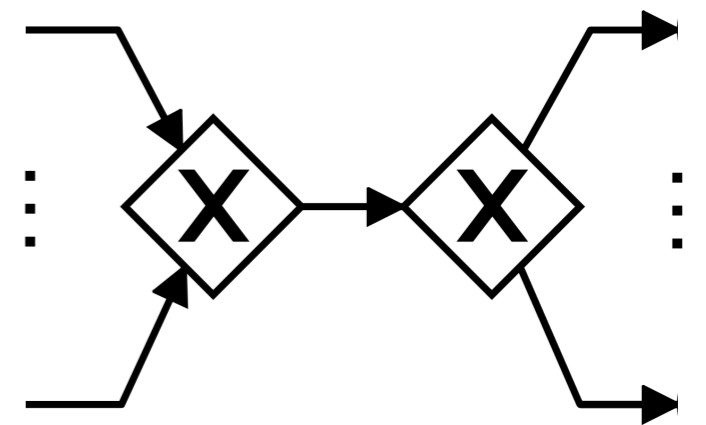

stands for

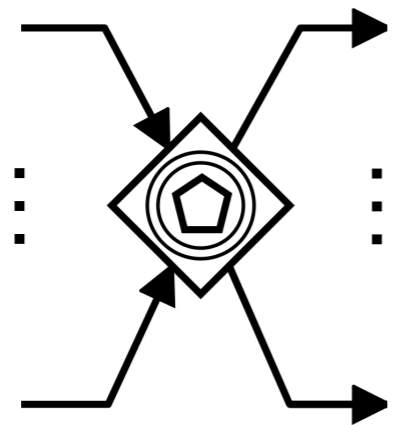
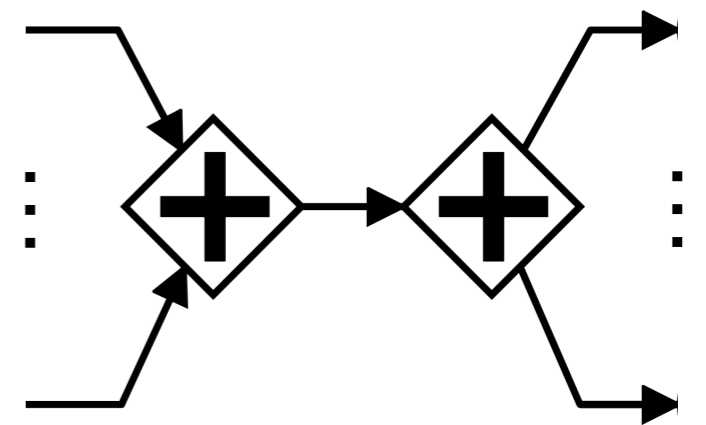

stands for

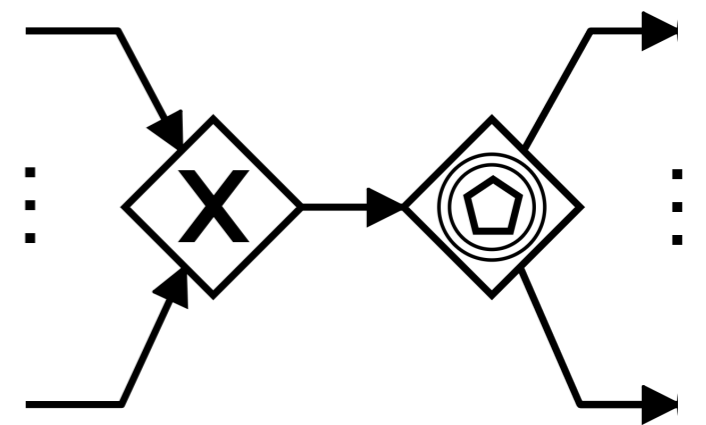

My suggestions

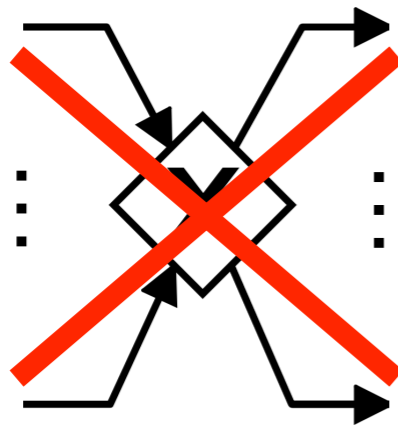

stands for

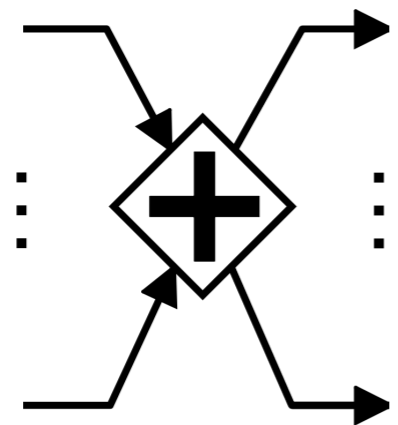
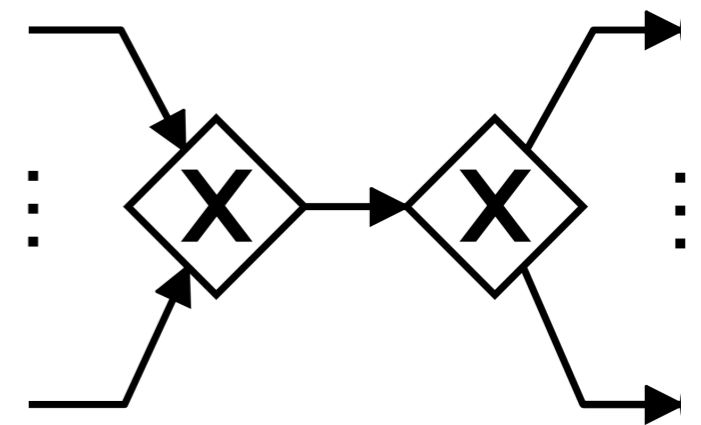

stands for

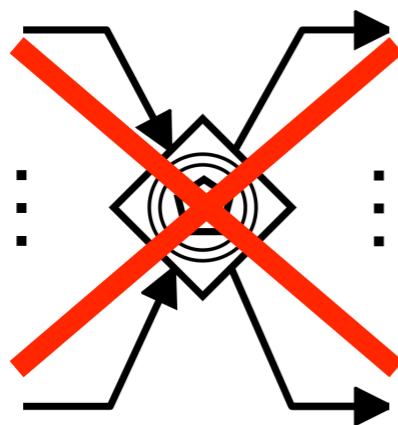
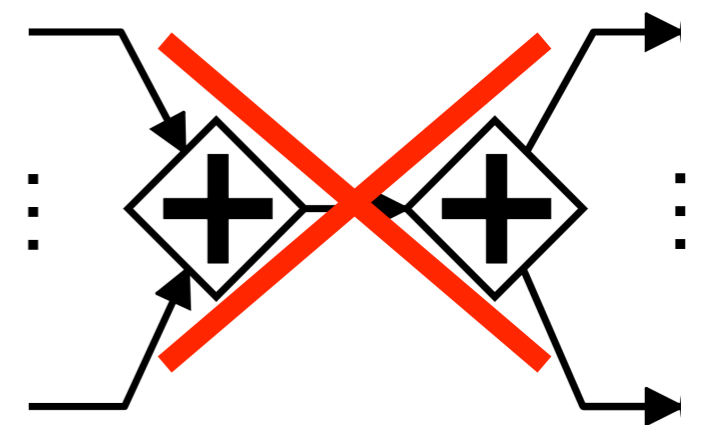

stands for

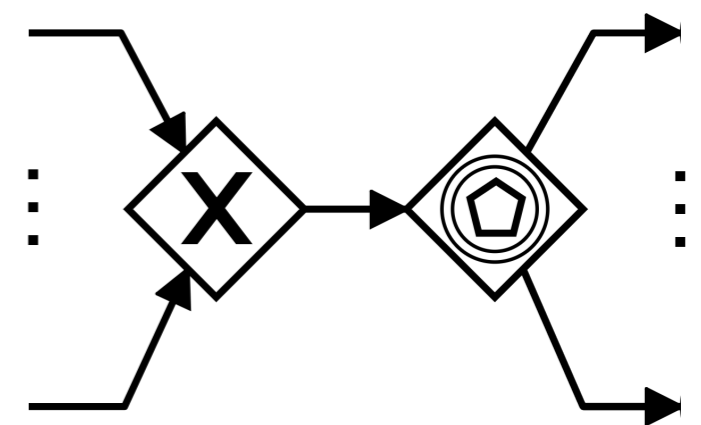

Simplified BPMN

Avoid OR-gateways

(all problems seen with EPC apply to BPMN as well)

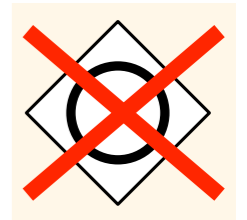

Limited form of sub-processing

No transactions and compensations

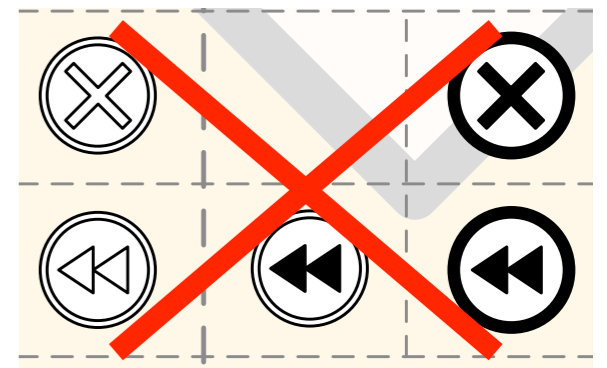

The twist!

BPMN object

net fragment

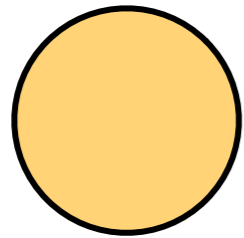

event

transition

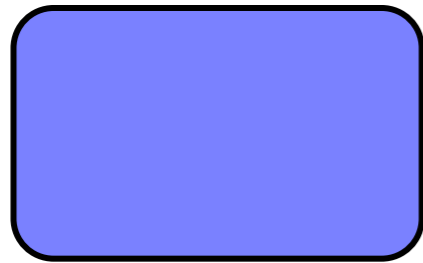
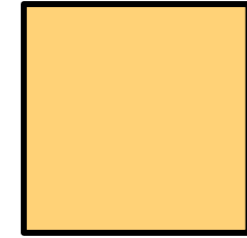

activity

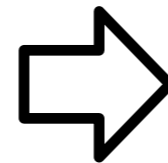

transition

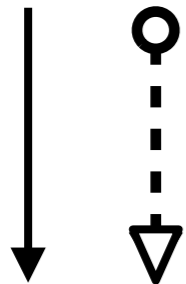
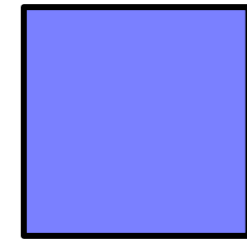

sequence flow
message flow

place

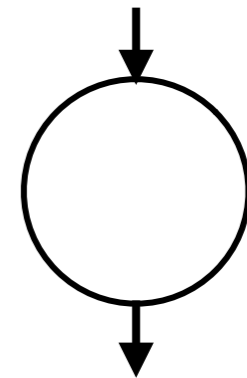

Roughly

A place for each arc

one transitions for each event

one transition for each activity

one or two transitions for each gateway

...

with some exceptions!

(start event, end event, event-based gateways, loops, ...)

no dummy objects!

The strategy

From BPMN process diagrams to wf nets in three steps

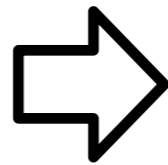
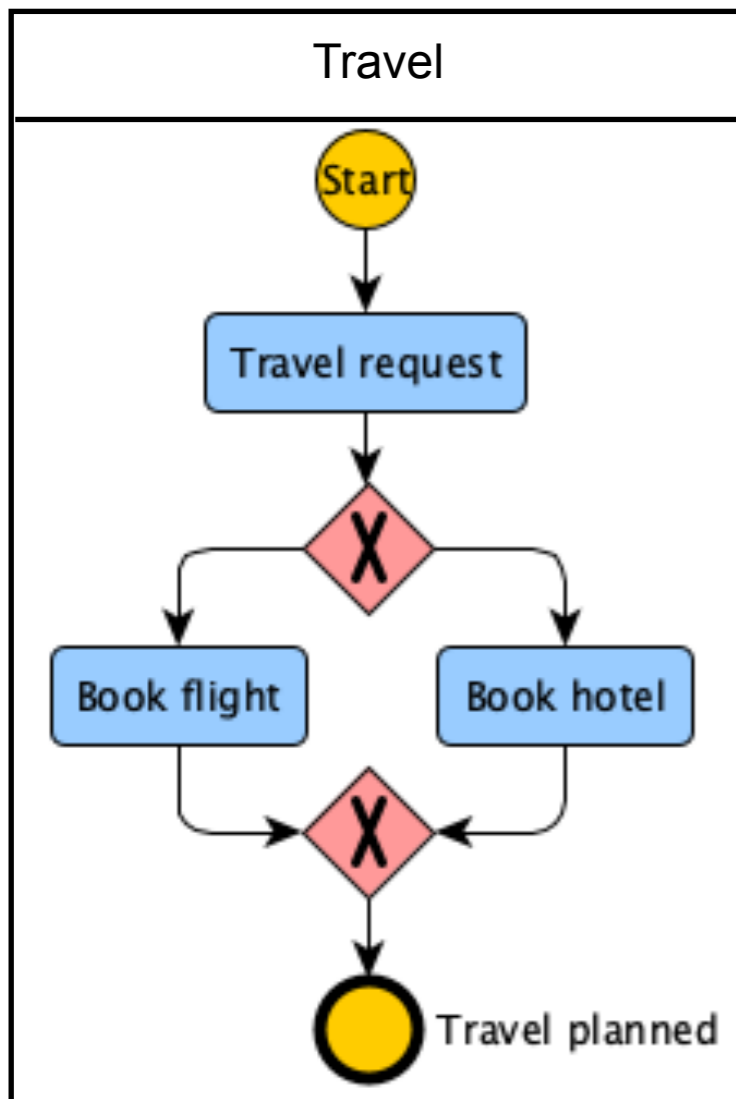

Step 1
convert
sequence flow
message flow

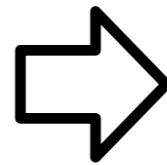

Step 2
convert
flow objects

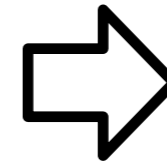

Step 3
enforce
initial place
final place



Step 1: convert flows

We insert a place for each sequence flow and message flow

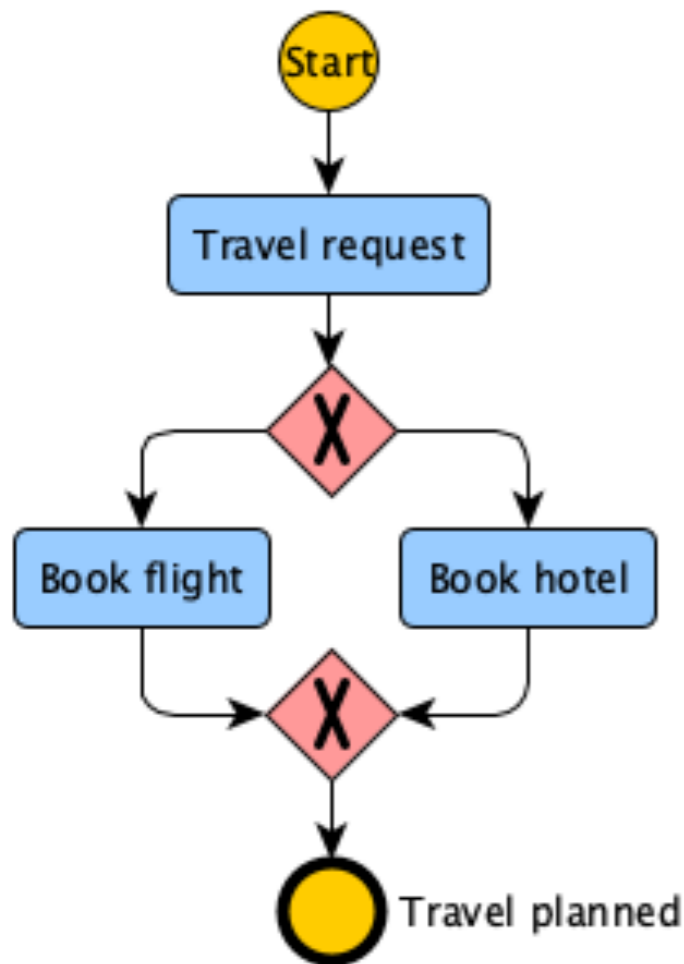

➔
Step 1
sequence flow
message flow

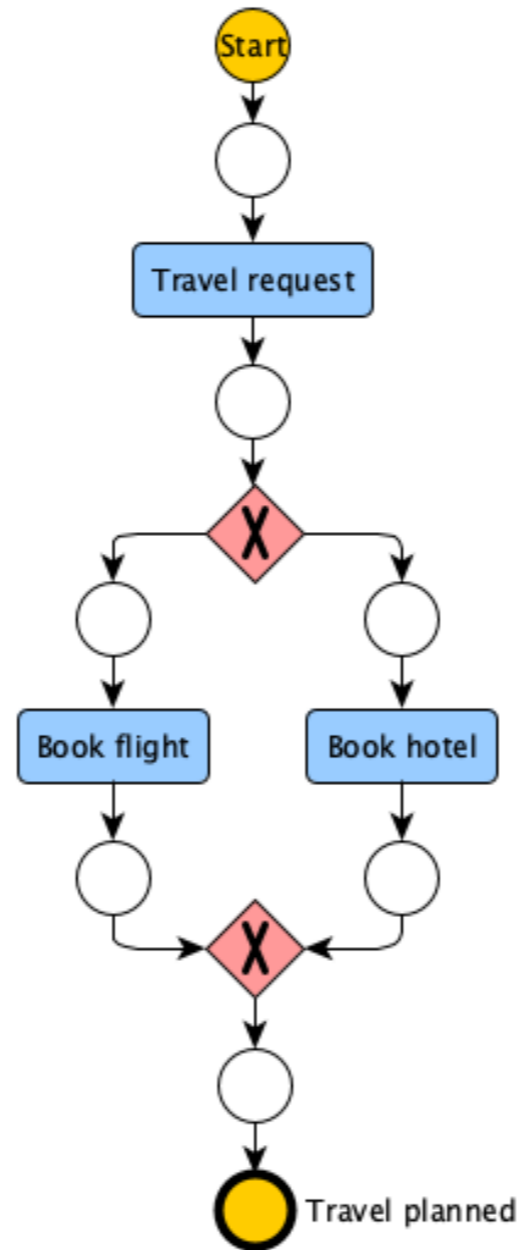

Step 2: convert flow objects

Then insert transitions

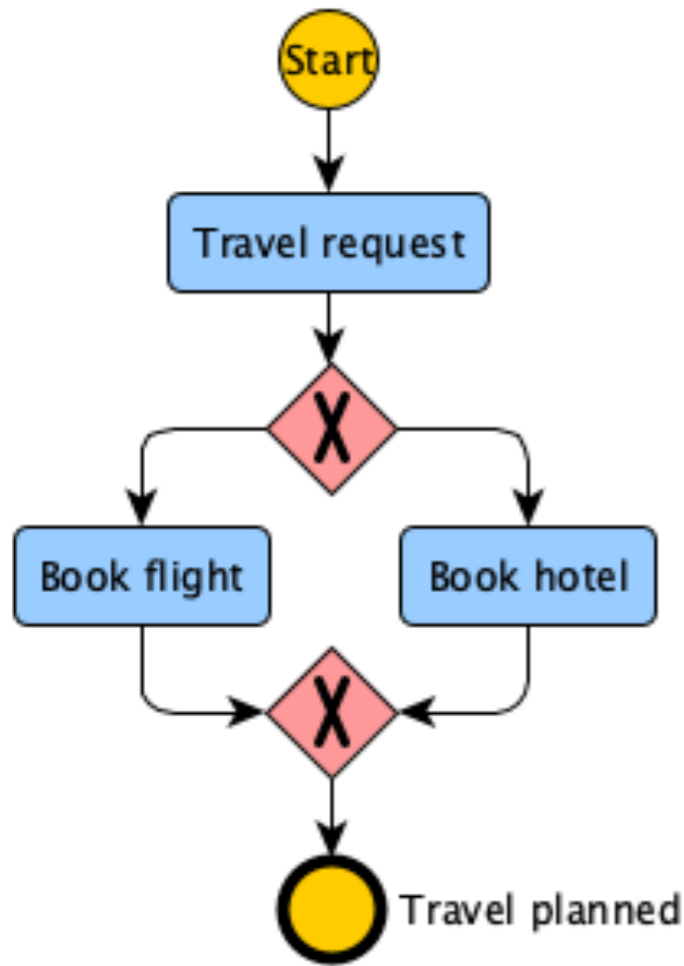

Step 1
sequence flow
message flow

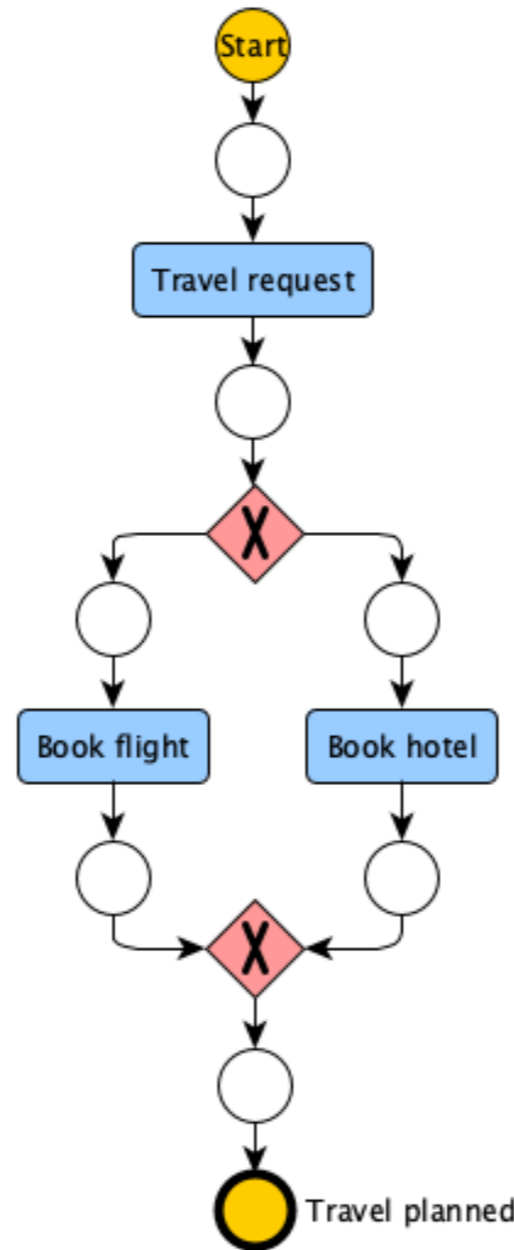
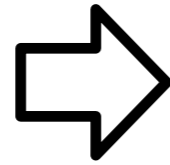

Step 2
flow objects

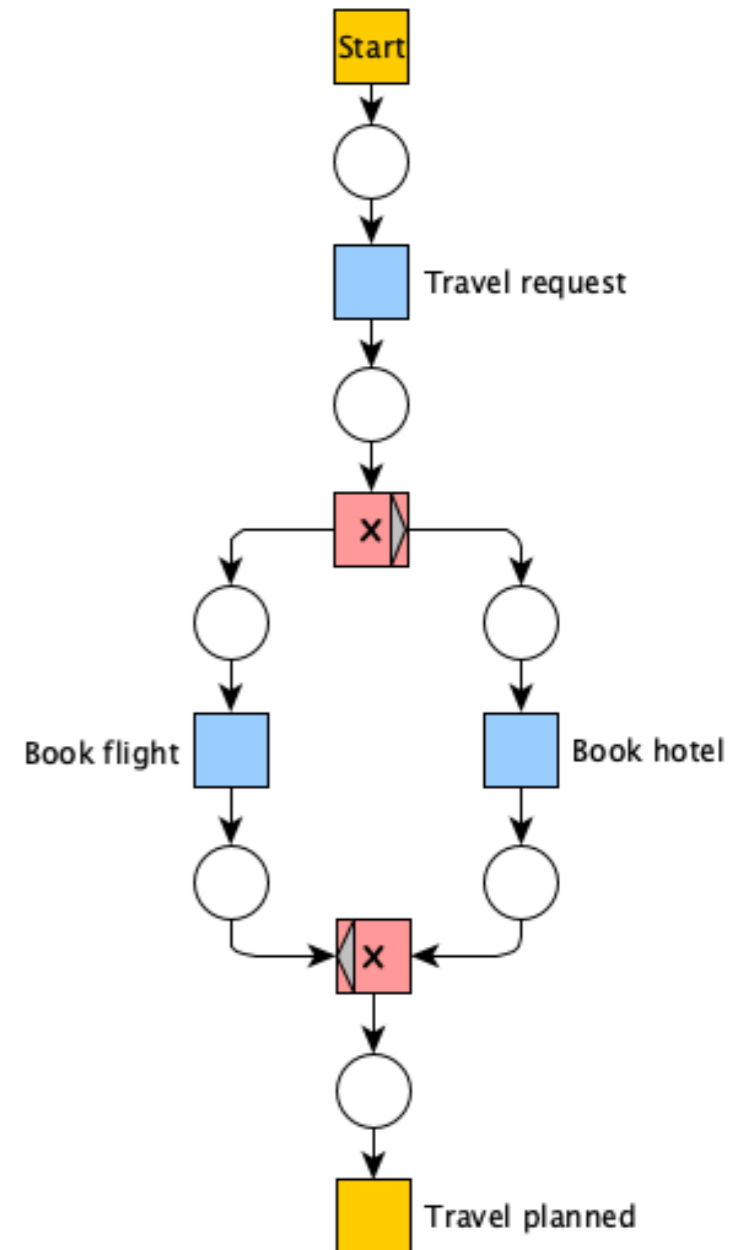
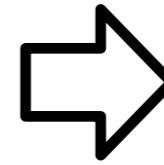

Step 2: gateways

BPMN object

net fragment

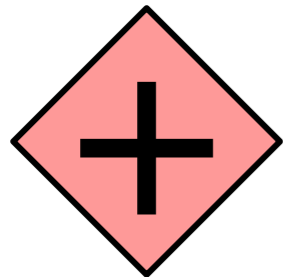

AND split / join

transition

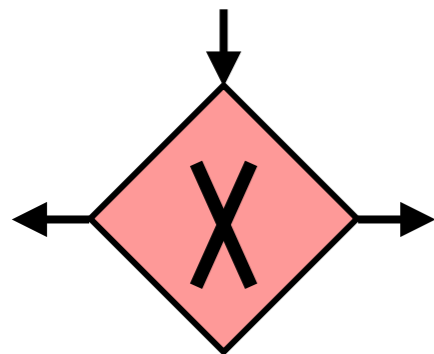
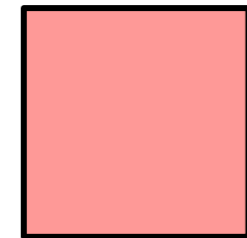

XOR split

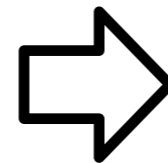

transition

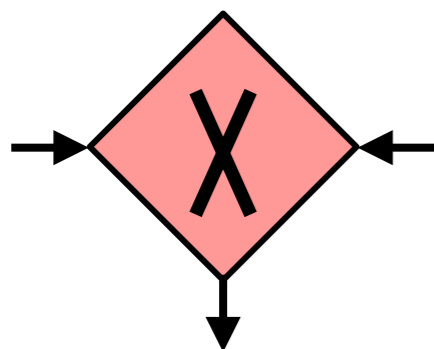
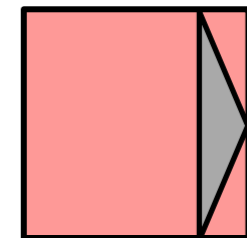

XOR join

transition

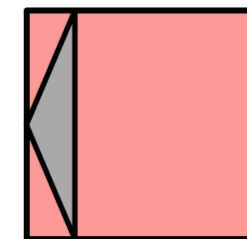

Step 2: event-based

BPMN object

net fragment

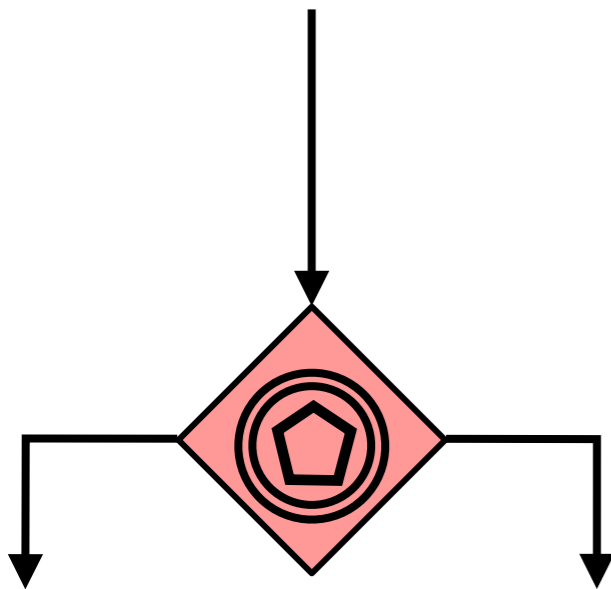

Step 1
sequence flow
message flow

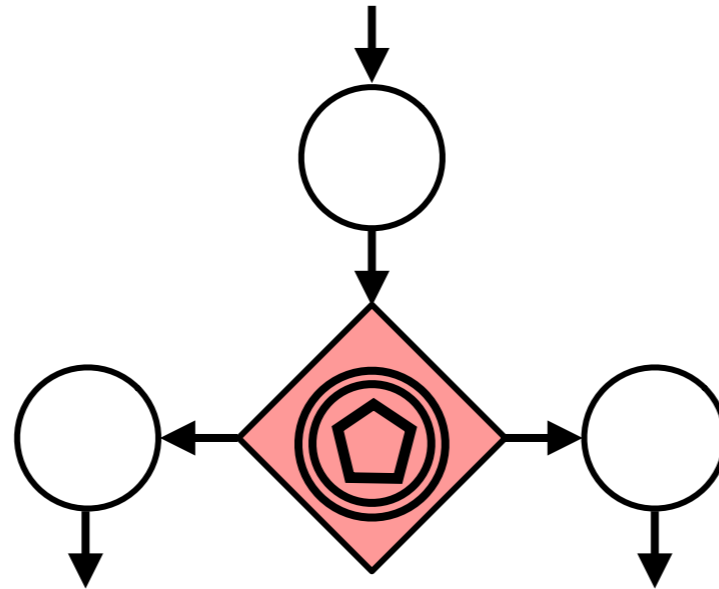

Step 2
place fusion

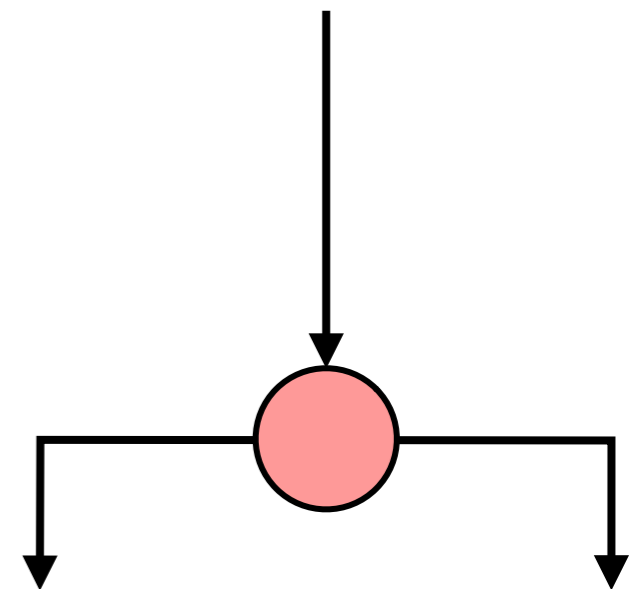

Step 3: add unique start

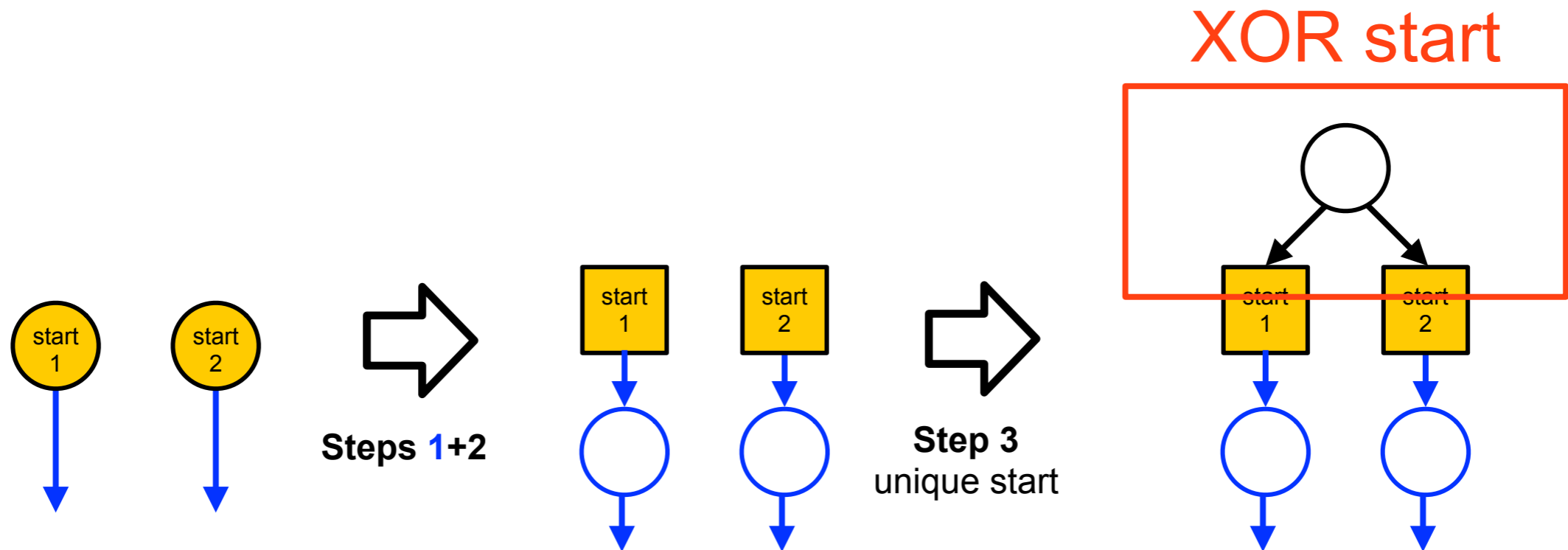

Step 3: add unique end

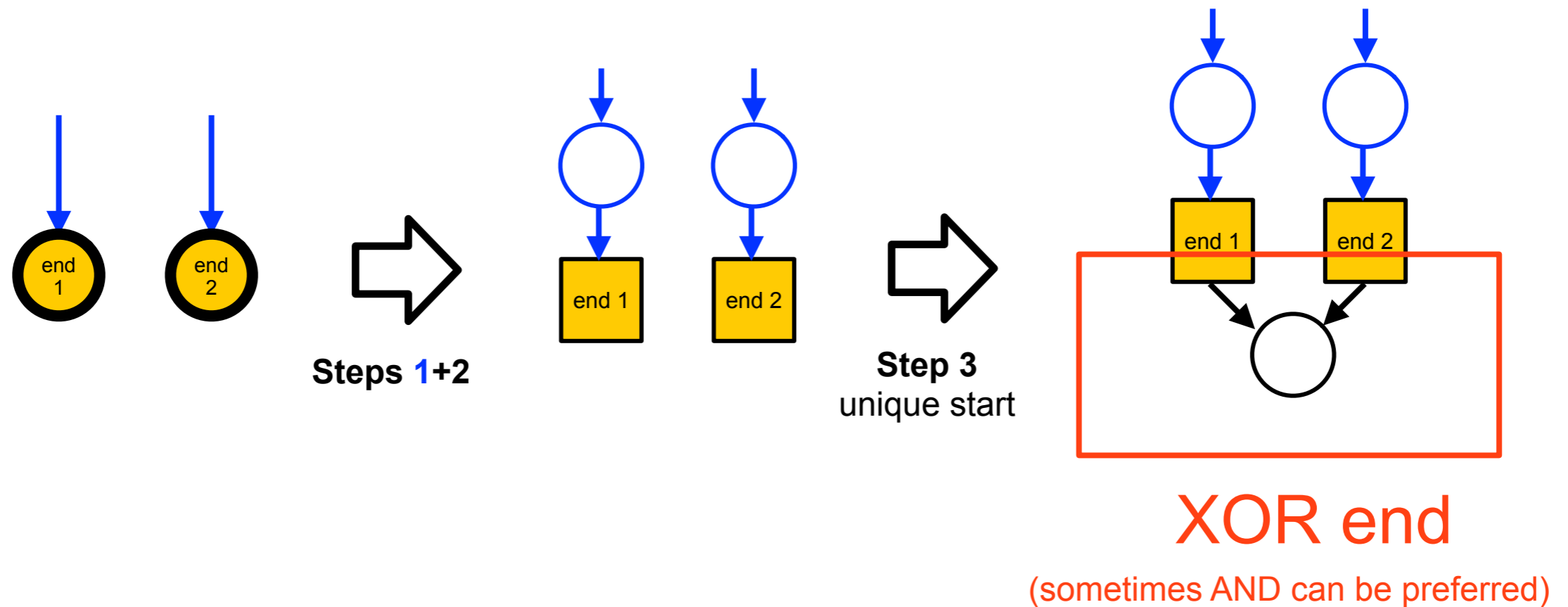

Example: Order process

Order process

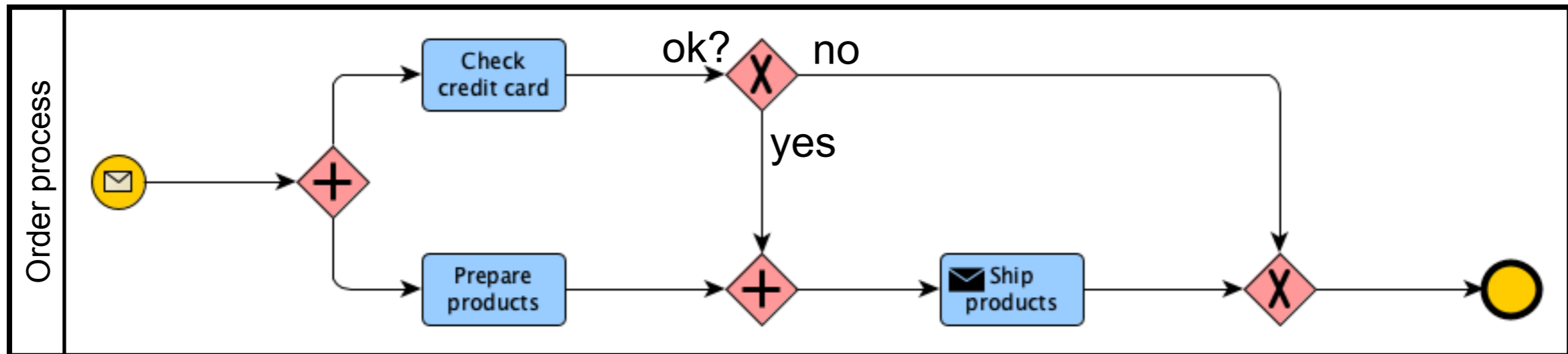

Sound?

Order process: step 1

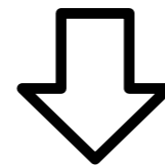
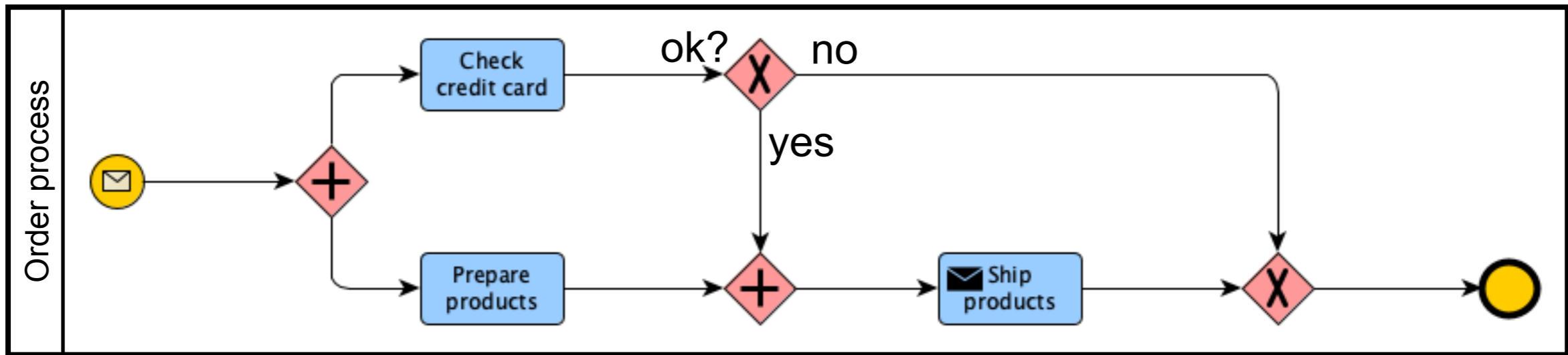

Step 1
sequence flow
message flow

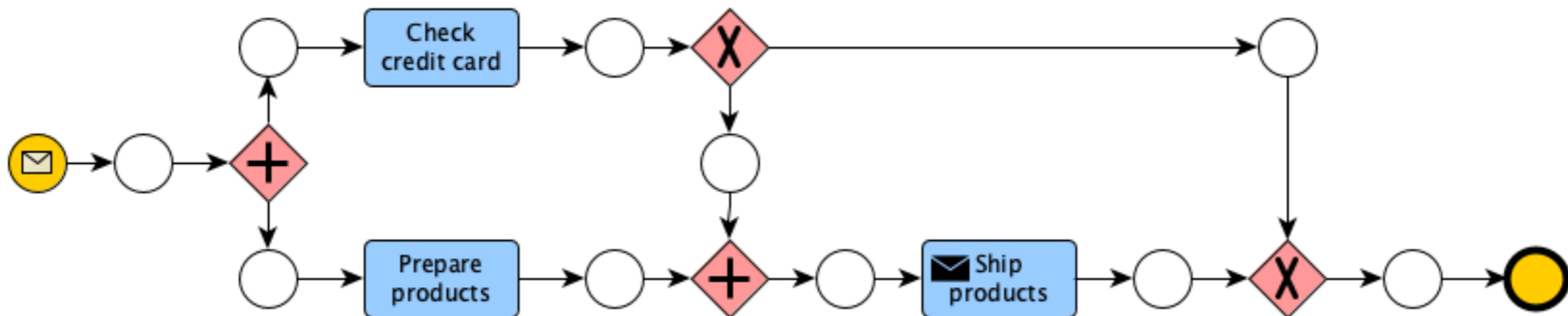

Order process: step 2

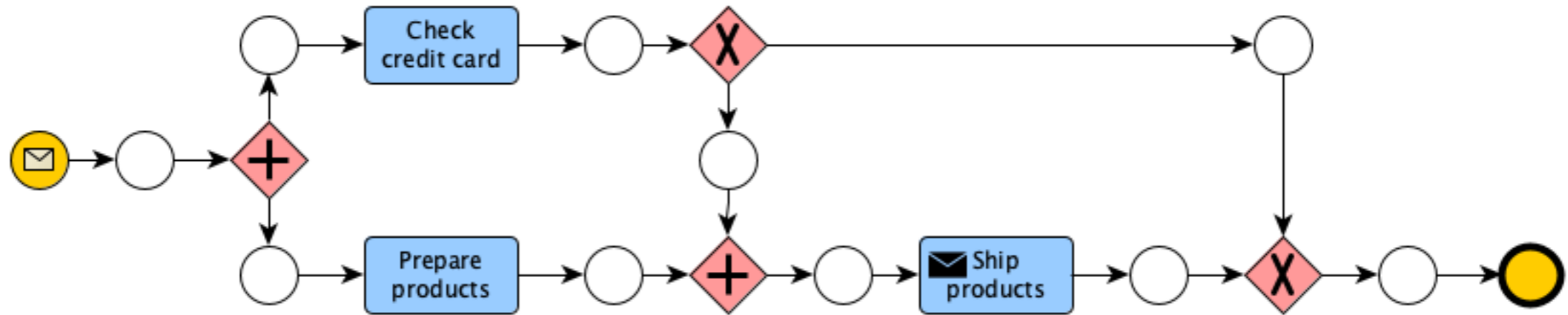

↓
Step 2
flow objects

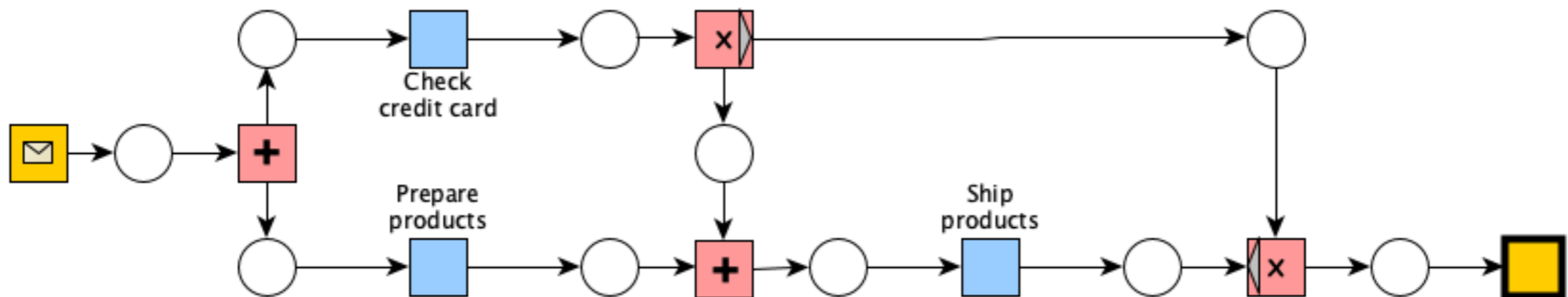

Order process: (desugar)

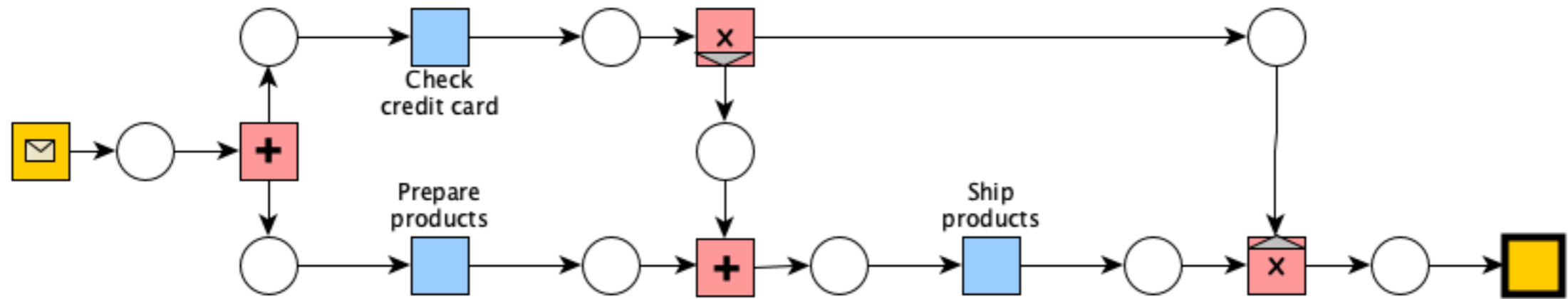

↓ desugar

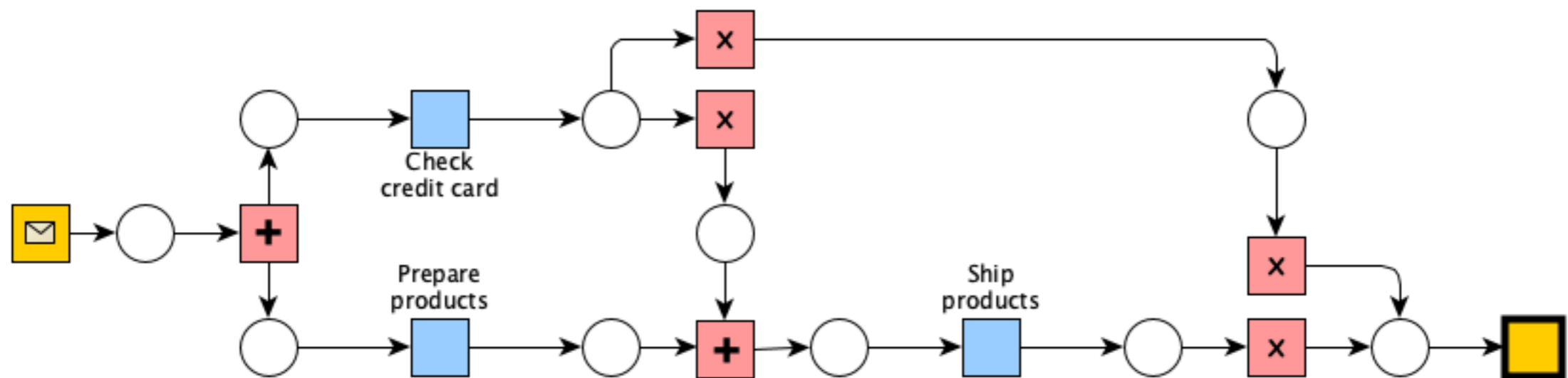

Order process: step 3

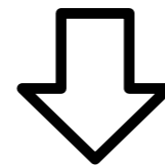
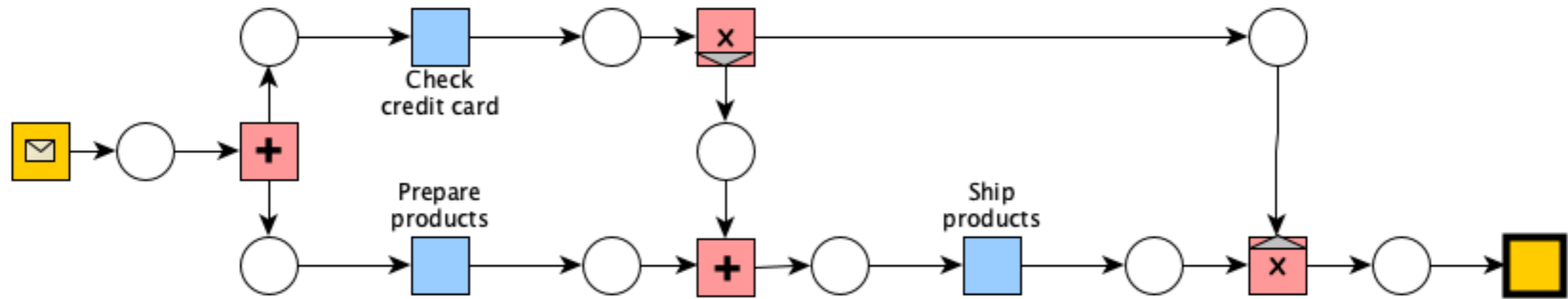

Step 3
enforce
initial place
final place

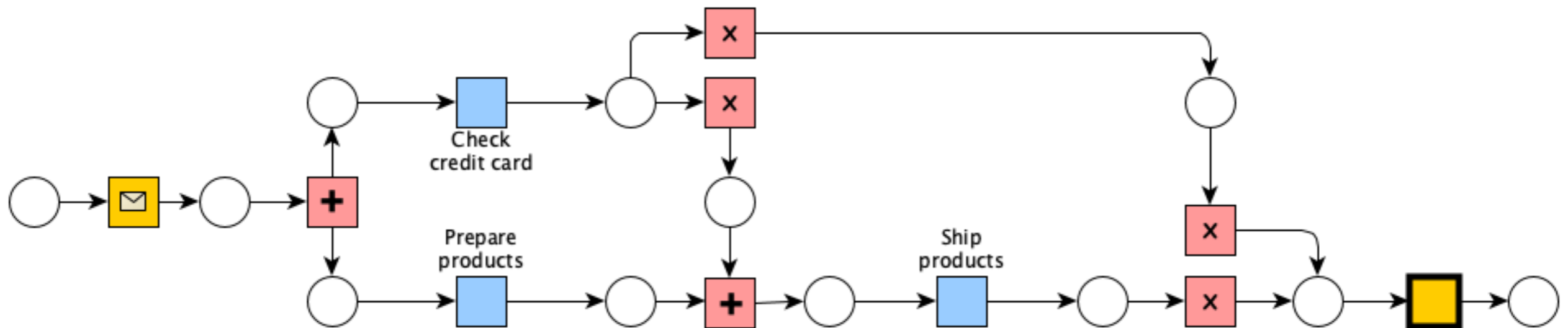

Soundness analysis

Not sound!

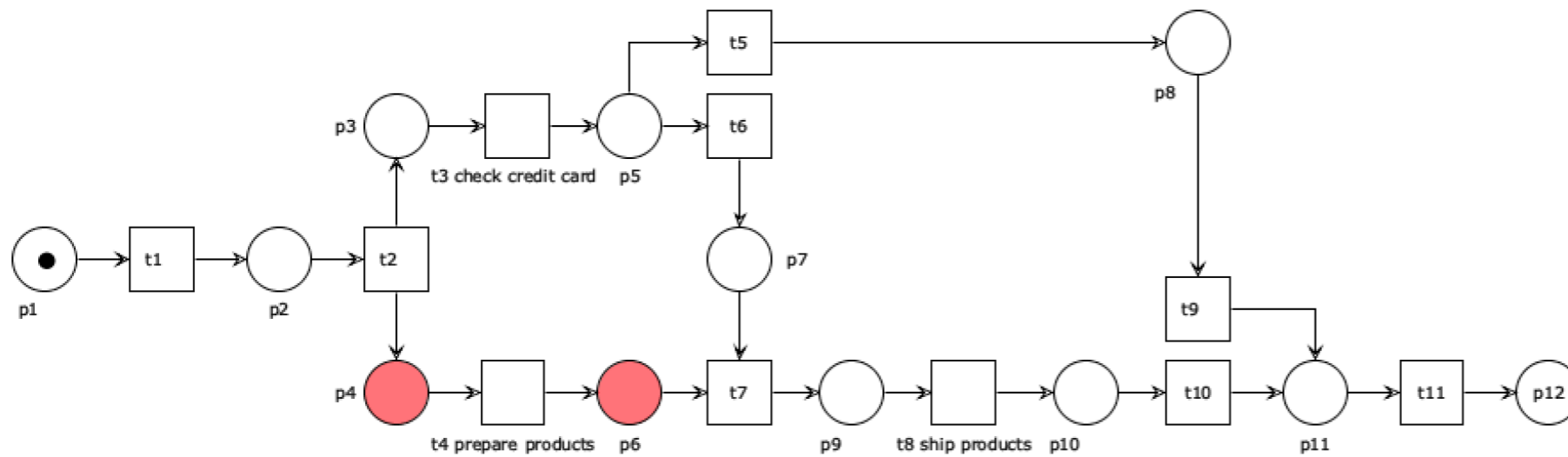

Semantical analysis

Wizard Expert

- Qualitative analysis
 - Structural analysis
 - Net statistics
 - Wrongly used operators: 0
 - Free-choice violations: 0
 - S-Components
 - S-Components: 1
 - Places not covered by S-Component
 - p4
 - p6
 - Wellstructuredness
 - PT-Handles: 1
 - TP-Handles: 1
 - Soundness
 - Workflow net property
 - Initial marking
 - Boundedness
 - Unbounded places: 2
 - p4
 - p6
 - Liveness

Soundness analysis

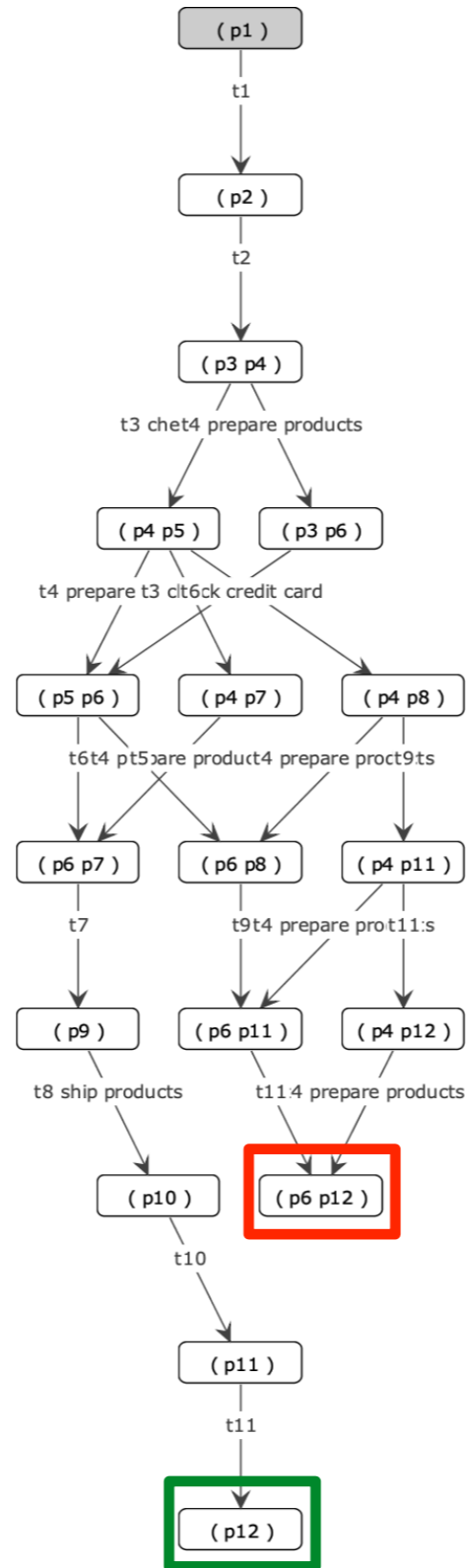

Soundness analysis

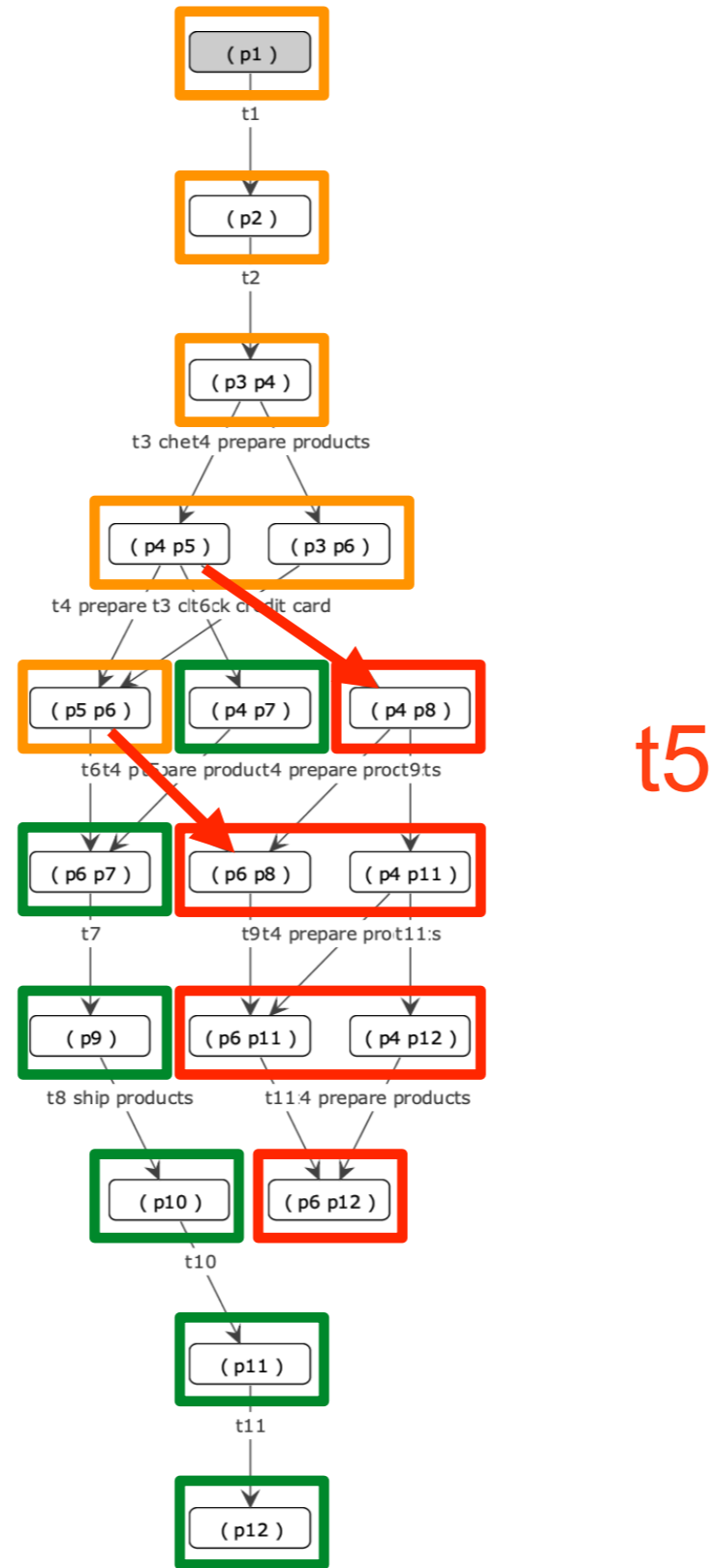

Soundness analysis

Not sound!

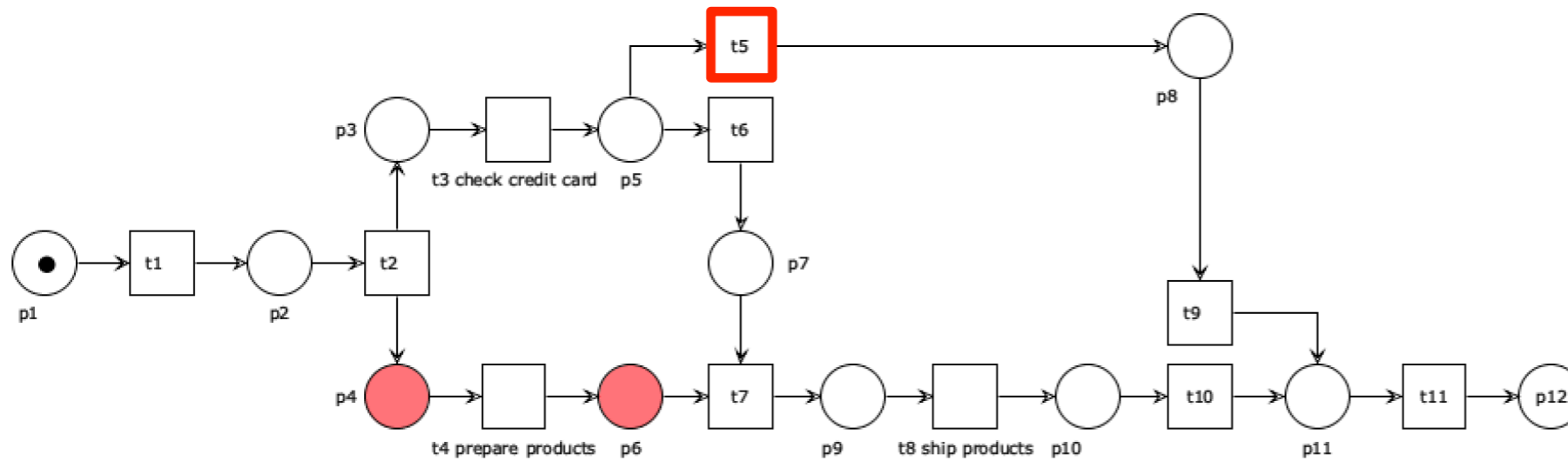

Semantical analysis

Wizard Expert

- Qualitative analysis
 - Structural analysis
 - Net statistics
 - Wrongly used operators: 0
 - Free-choice violations: 0
 - S-Components
 - S-Components: 1
 - Places not covered by S-Comp
 - p4
 - p6
 - Wellstructuredness
 - PT-Handles: 1
 - TP-Handles: 1
 - Soundness
 - Workflow net property
 - Initial marking
 - Boundedness
 - Unbounded places: 2
 - p4
 - p6
 - Liveness

Example: Travel itinerary

Travel itinerary

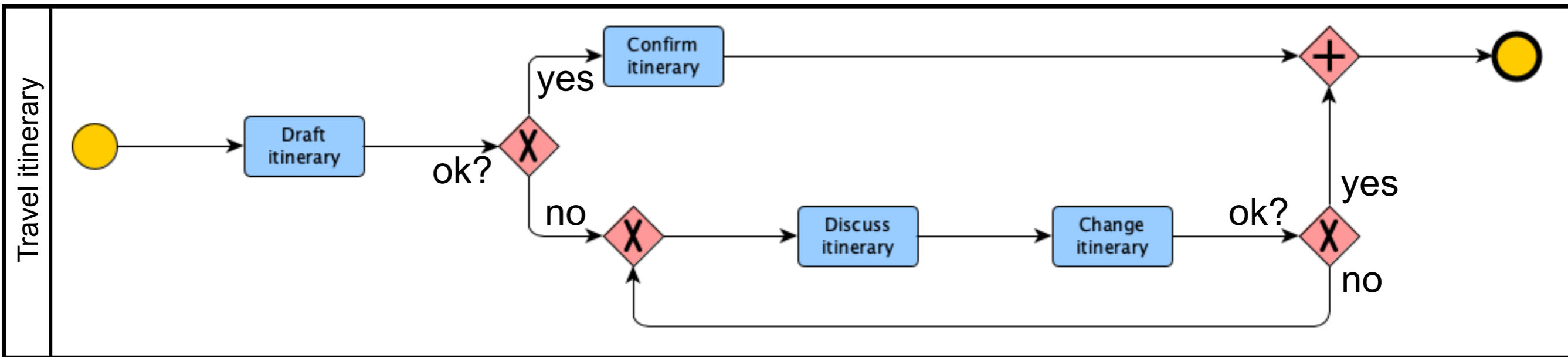

Sound?

Travel itinerary: step 1

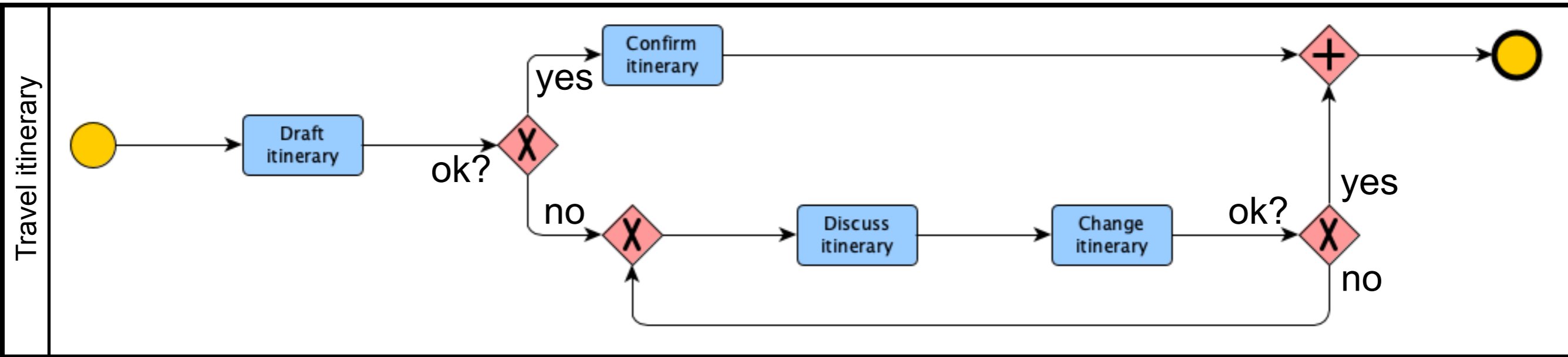

Step 1
sequence flow
message flow

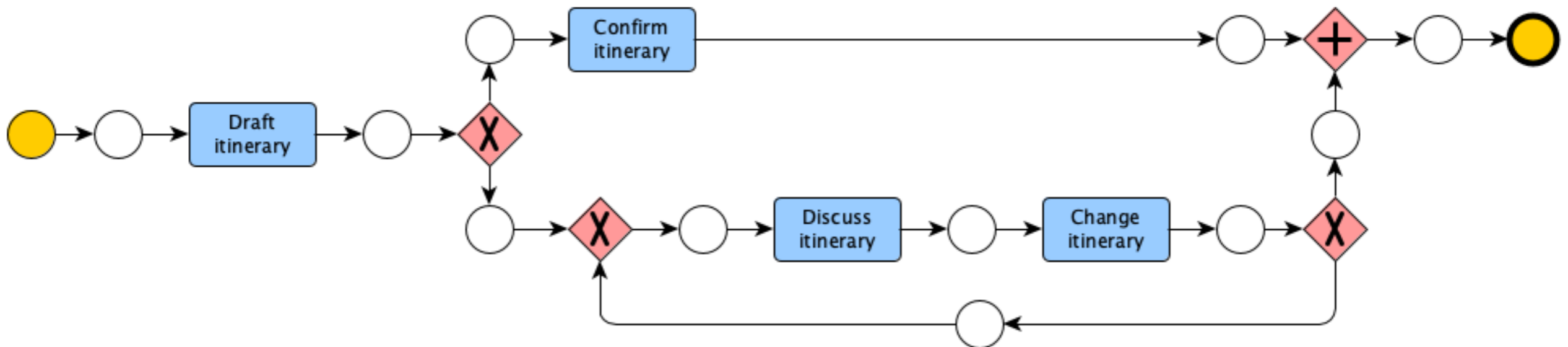

Travel itinerary: step 2

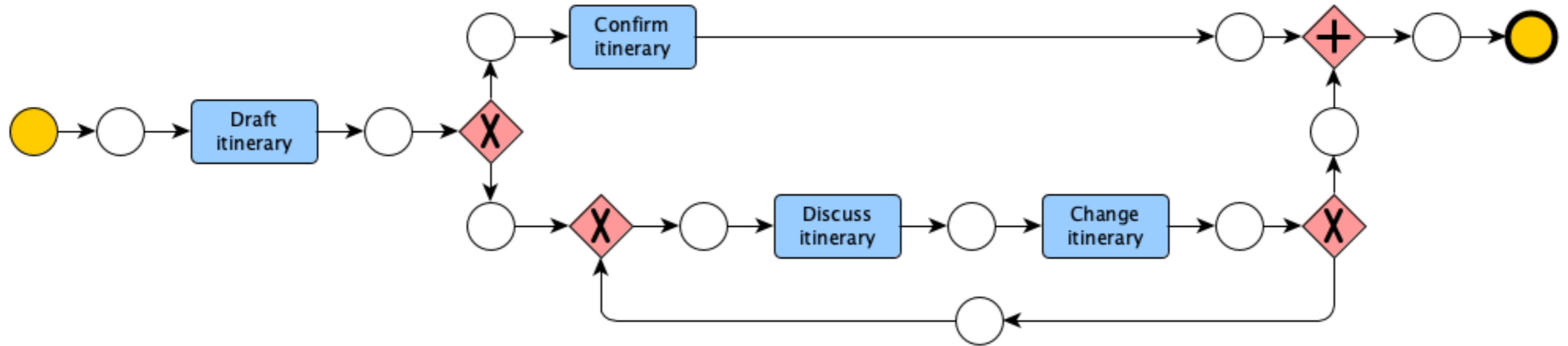

Step 2
flow objects

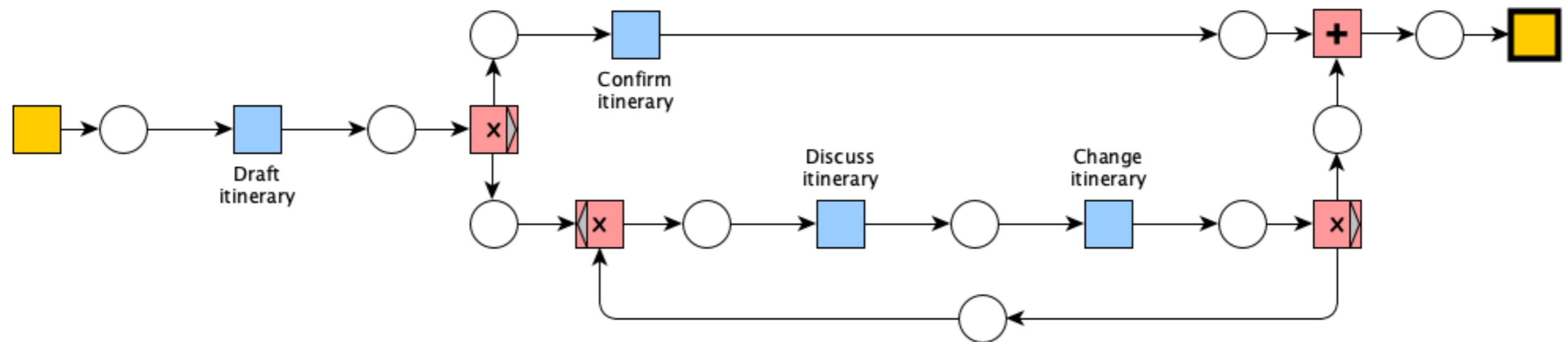

Travel itinerary: (desugar)

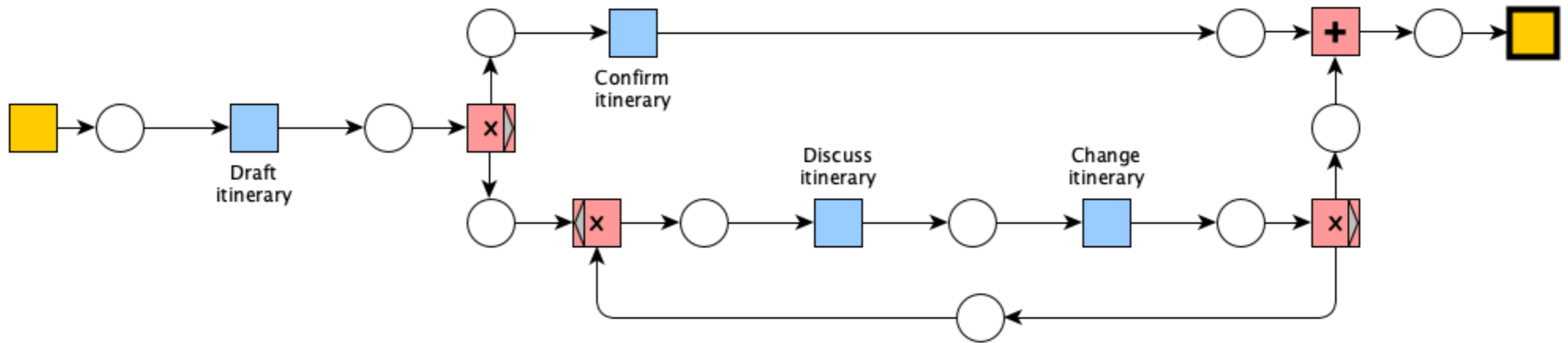

desugar

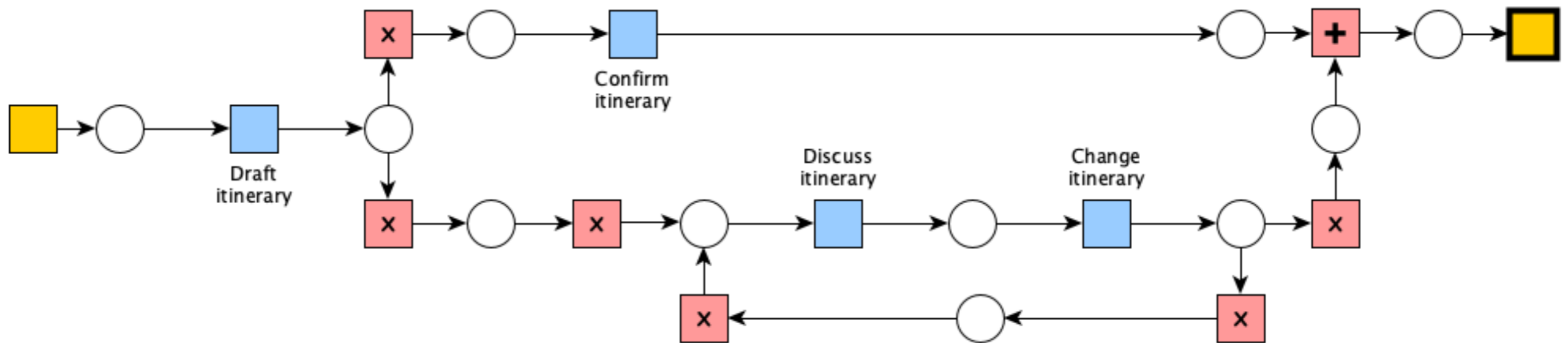

Travel itinerary: step 3

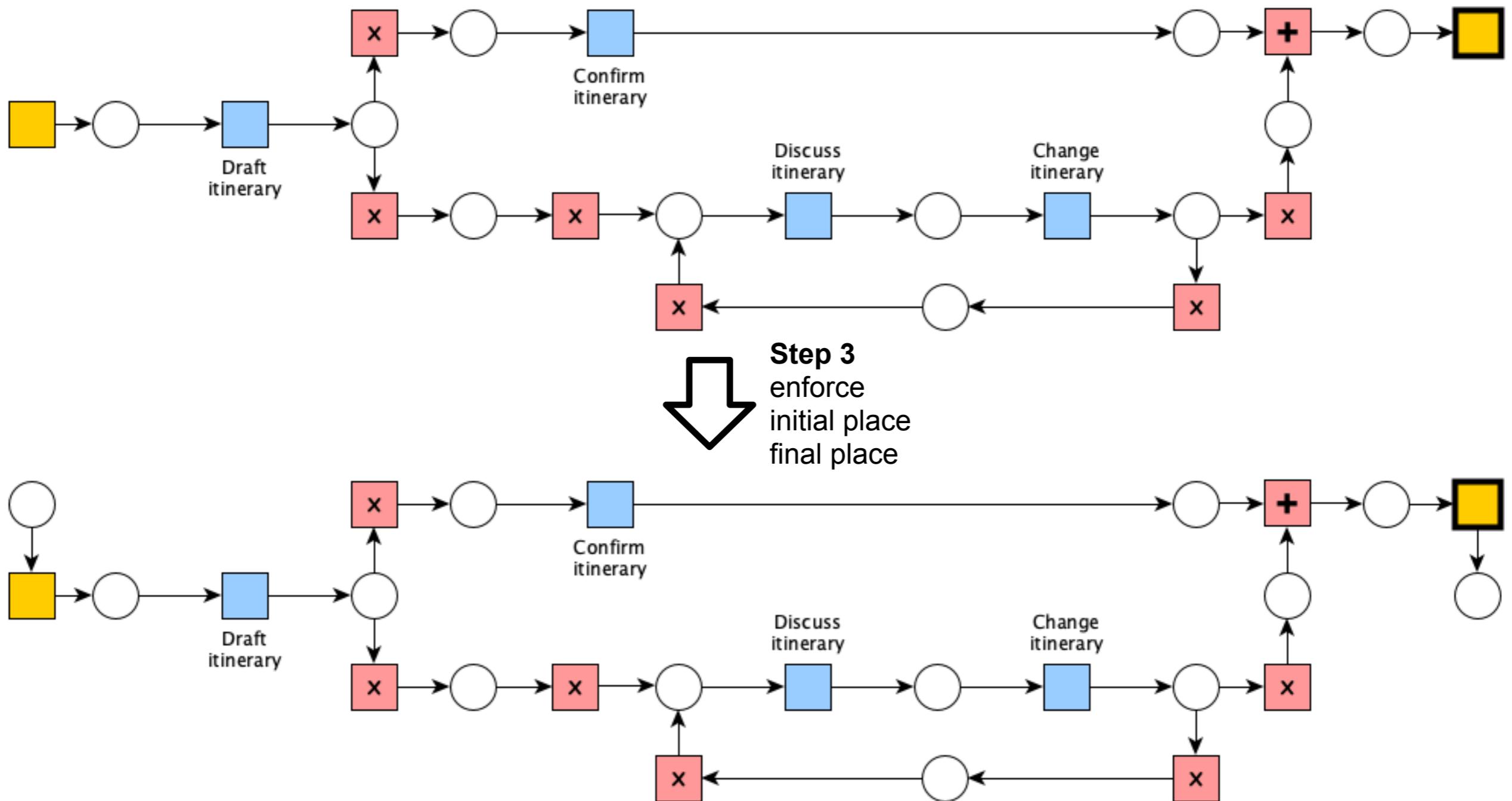

Soundness analysis

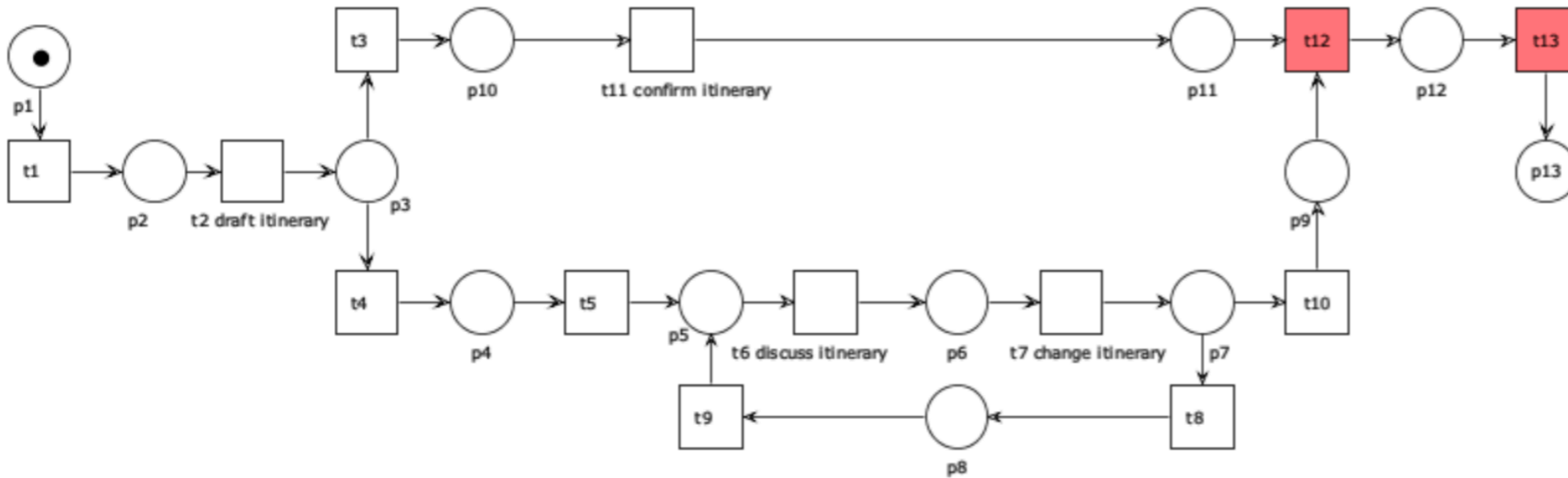

Not sound!

Semantical analysis

Wizard Expert

- Qualitative analysis
 - Structural analysis
 - Net statistics
 - Wrongly used operators: 0
 - Free-choice violations: 0
 - S-Components
 - S-Components: 0
 - Places not covered by S-Comp: 0
 - Wellstructuredness
 - PT-Handles: 1
 - TP-Handles: 0
 - Soundness
 - Workflow net property: ✓
 - Initial marking: ✓
 - Boundedness: ✓
 - Liveness
 - Dead transitions: 2
 - t13
 - t12
 - Non-live transitions: 13

Soundness analysis

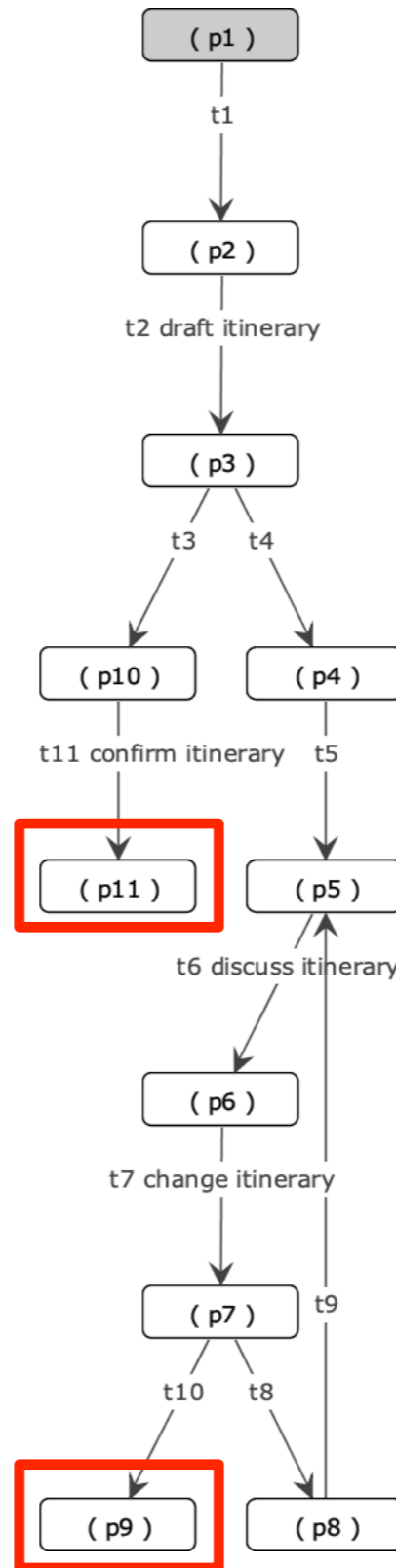

Example:
Always sushi

Always sushi

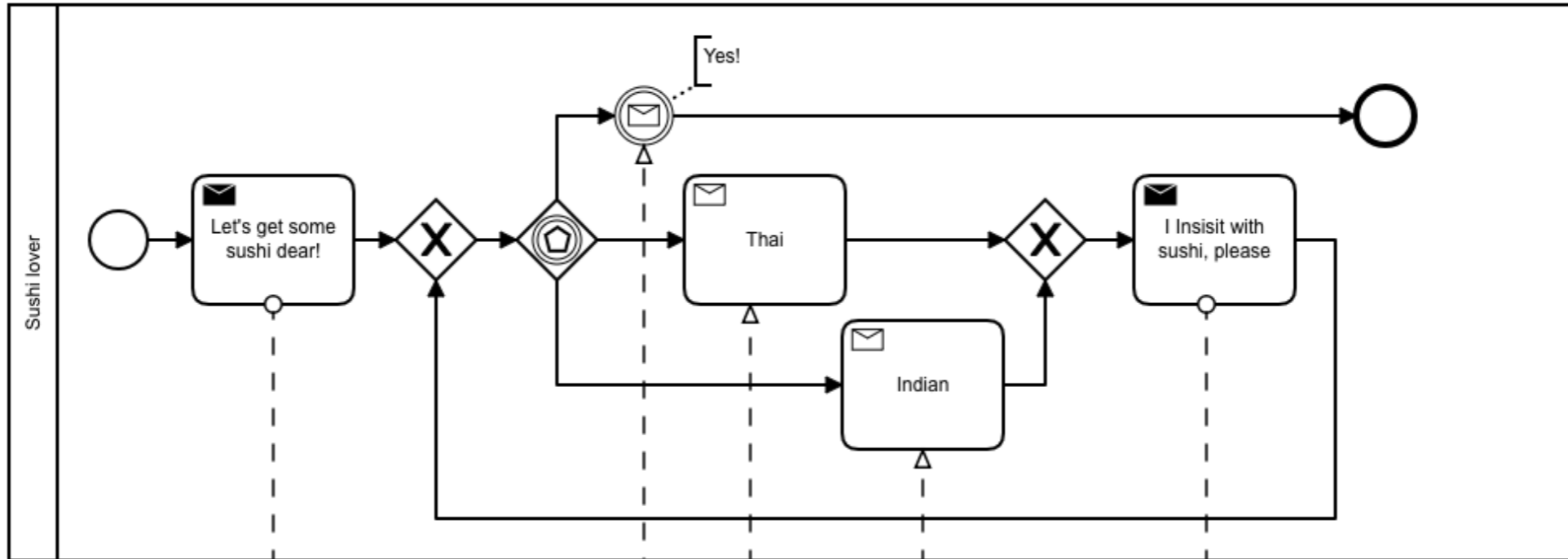

Sound?

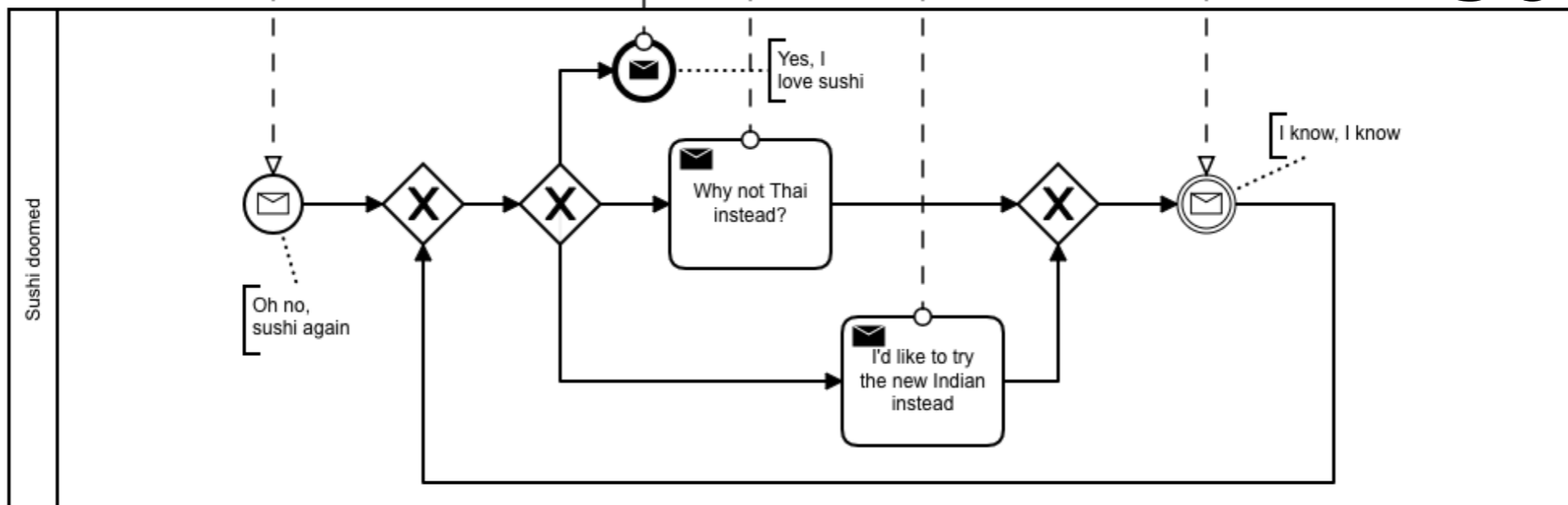

Sushi lover

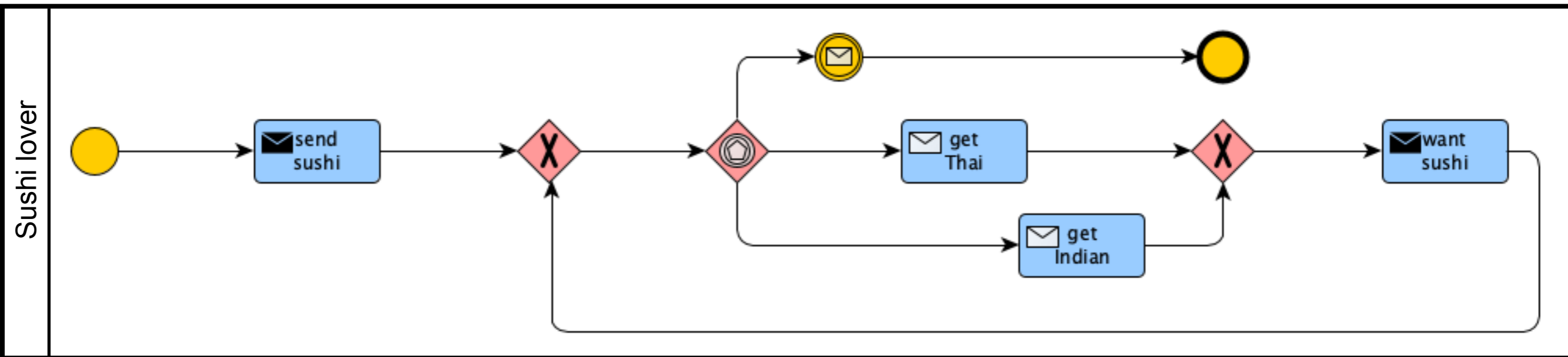

Sound?

Sushi lover: step 1

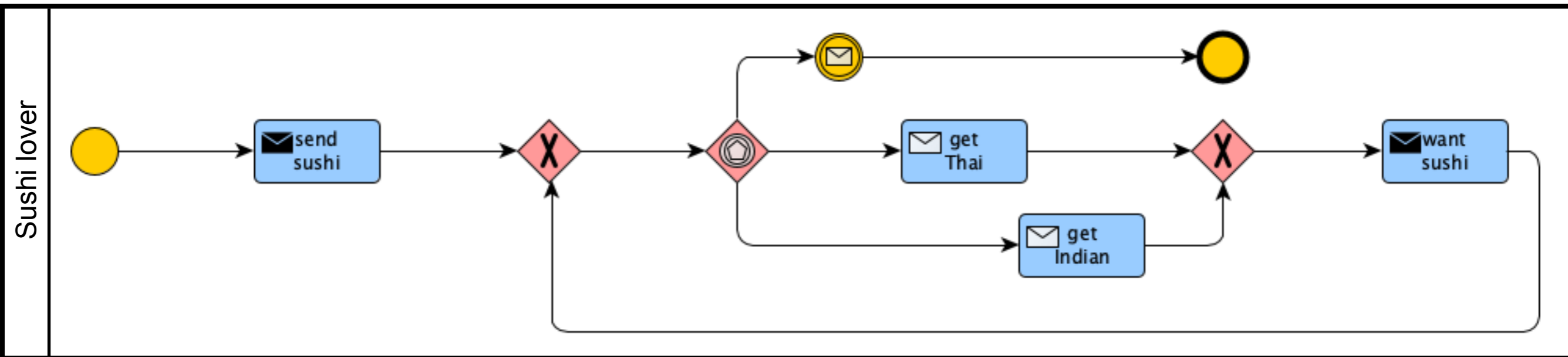

Step 1
sequence flow
message flow

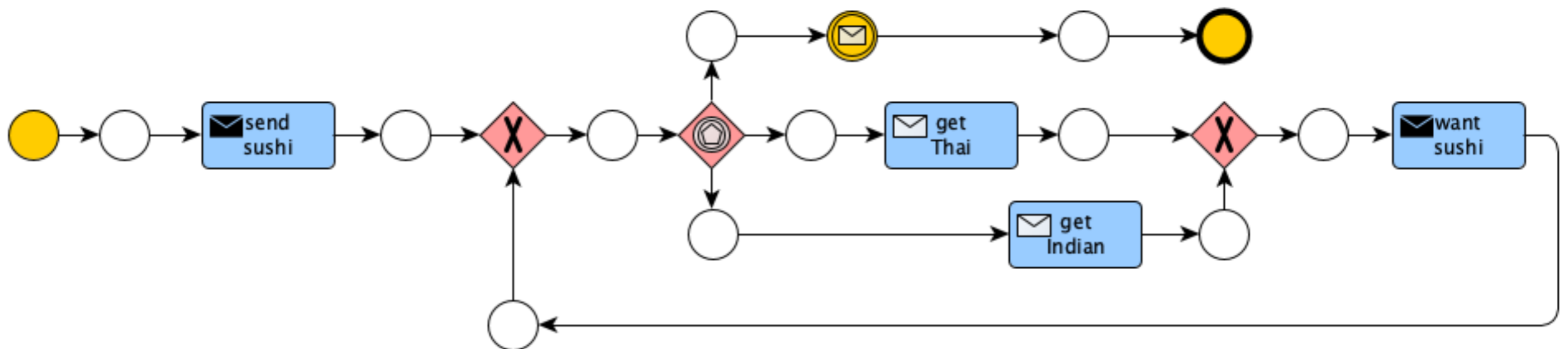

Sushi lover: step 2

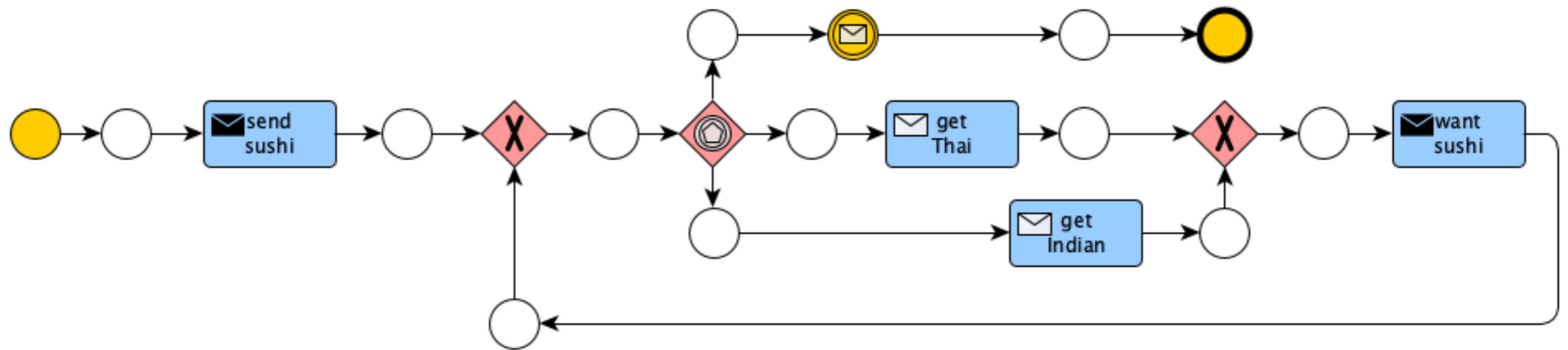

Step 2
flow objects

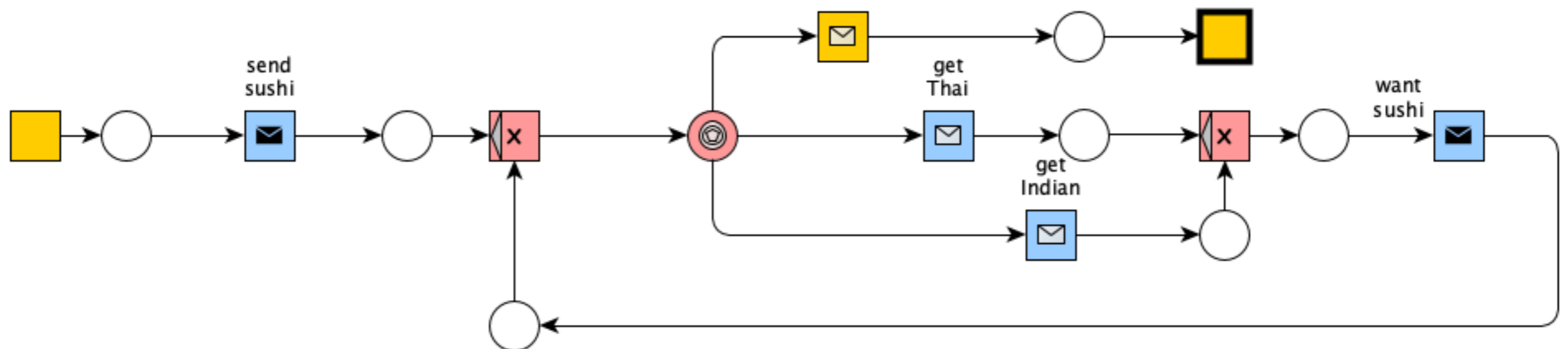

Sushi lover: (desugar)

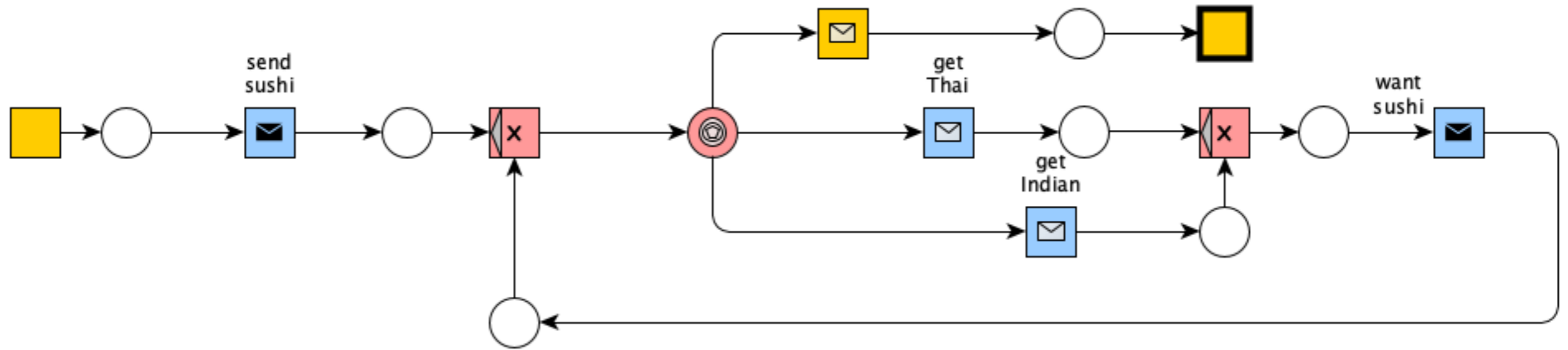

desugar

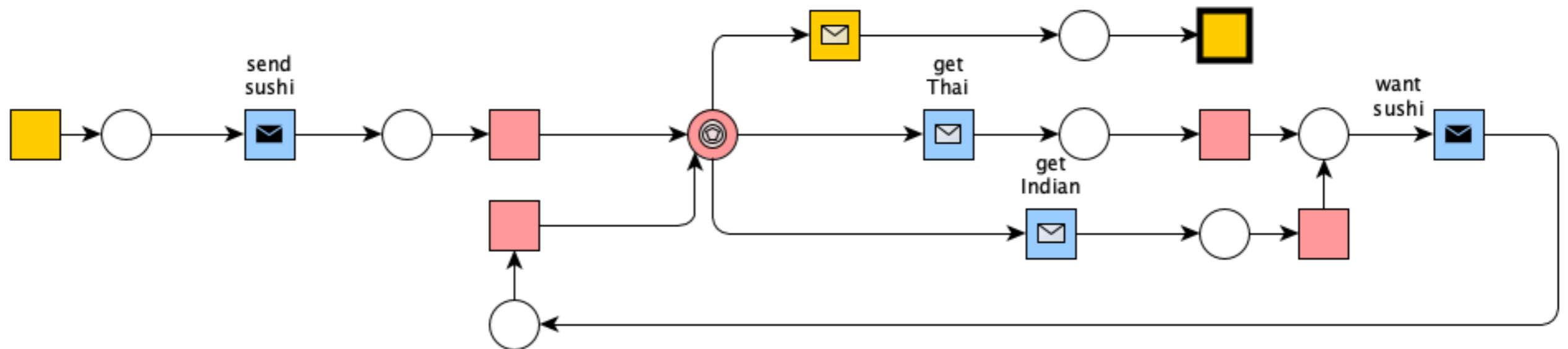

Sushi lover: step 3

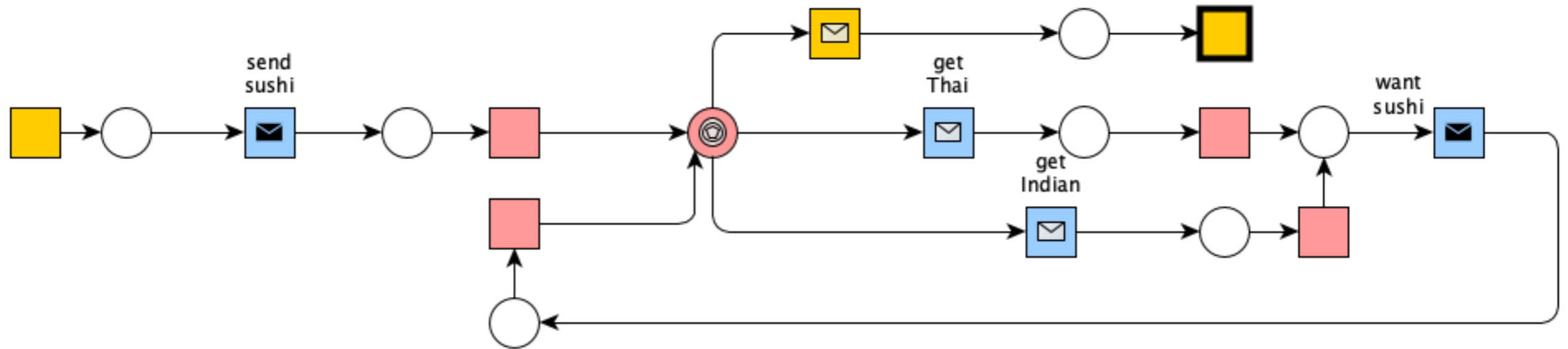

Step 3
enforce
initial place
final place

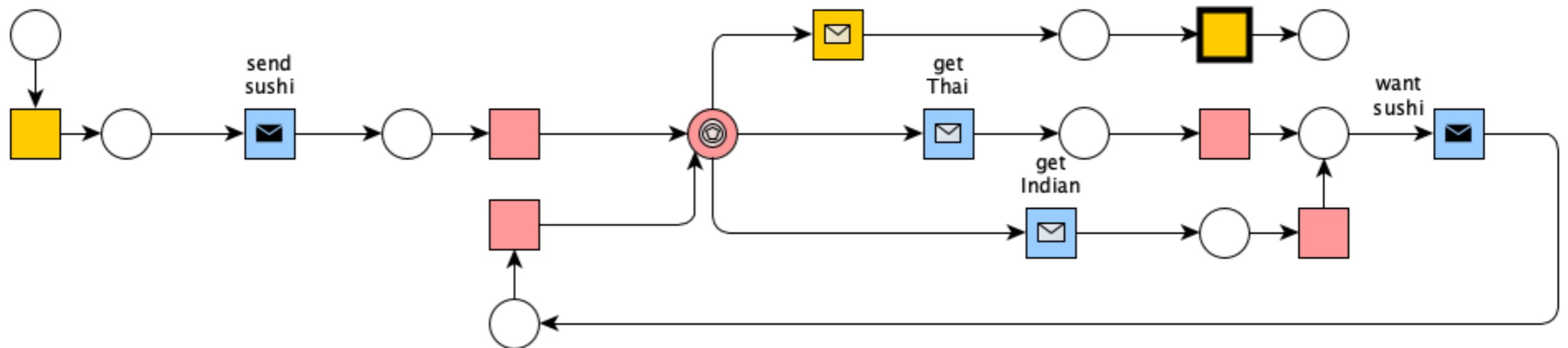

Soundness analysis

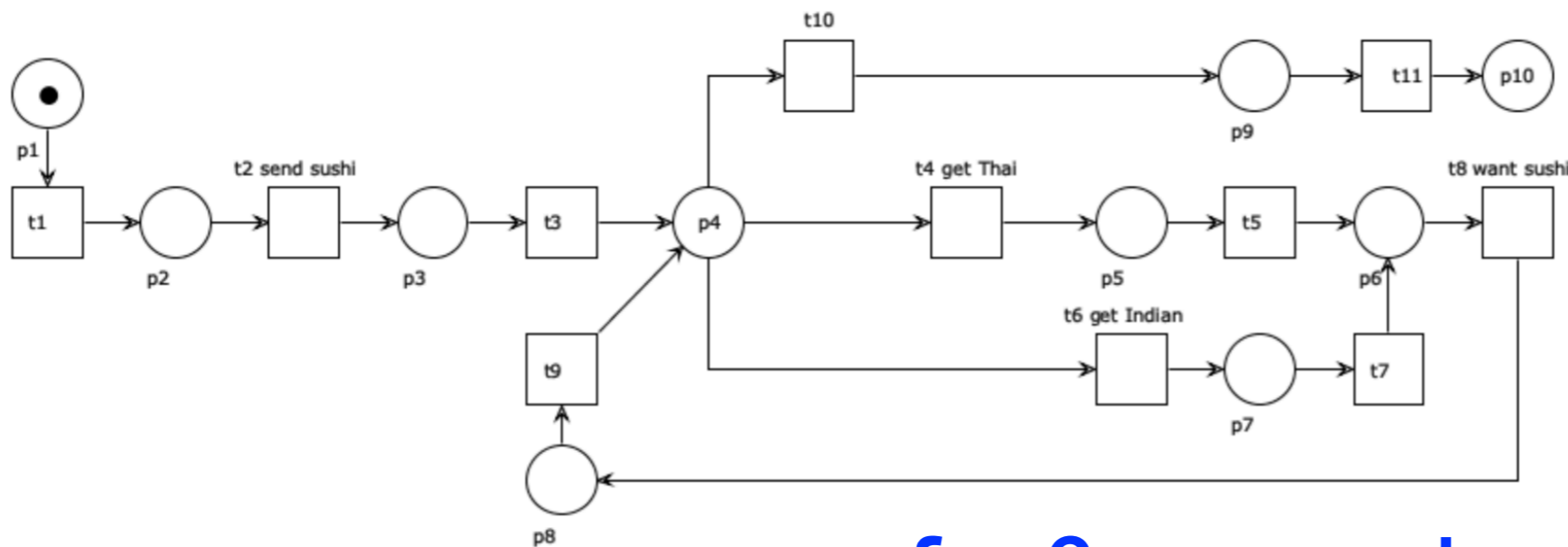

safe & sound
(s-net)

Semantical analysis

Wizard Expert

- Qualitative analysis
 - Structural analysis
 - Net statistics
 - Wrongly used operators: 0
 - Free-choice violations: 0
 - S-Components
 - S-Components: 1
 - Places not covered by S-Comp
 - Wellstructuredness
 - Soundness
 - Workflow net property
 - Initial marking
 - Boundedness
 - Liveness

Sushi doomed

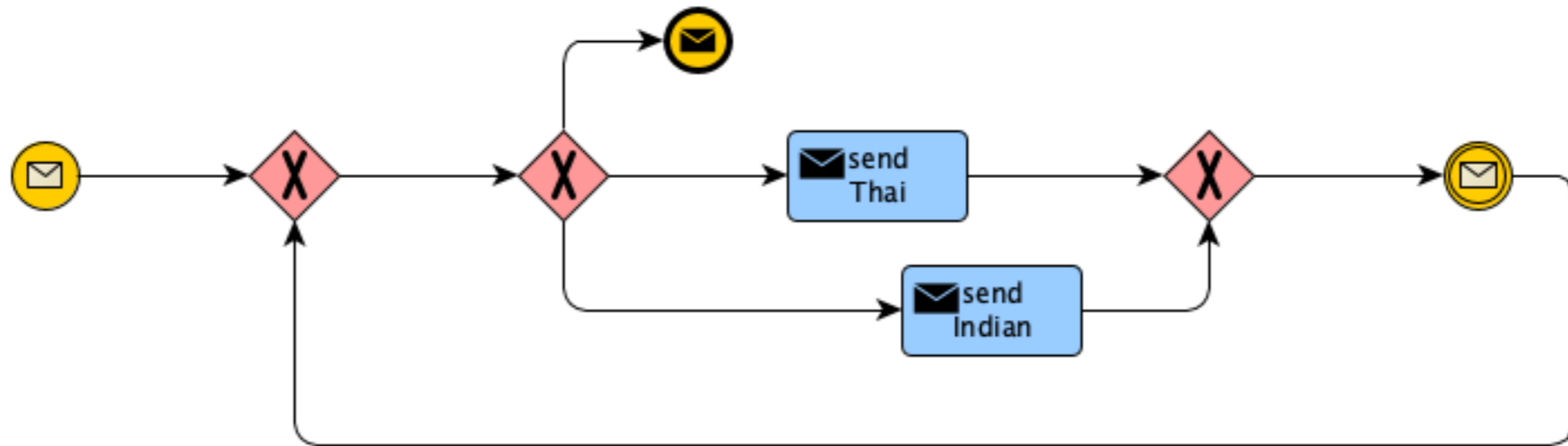

Sound?

Sushi doomed: step 1

Sushi doomed

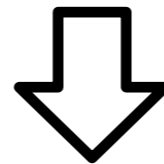
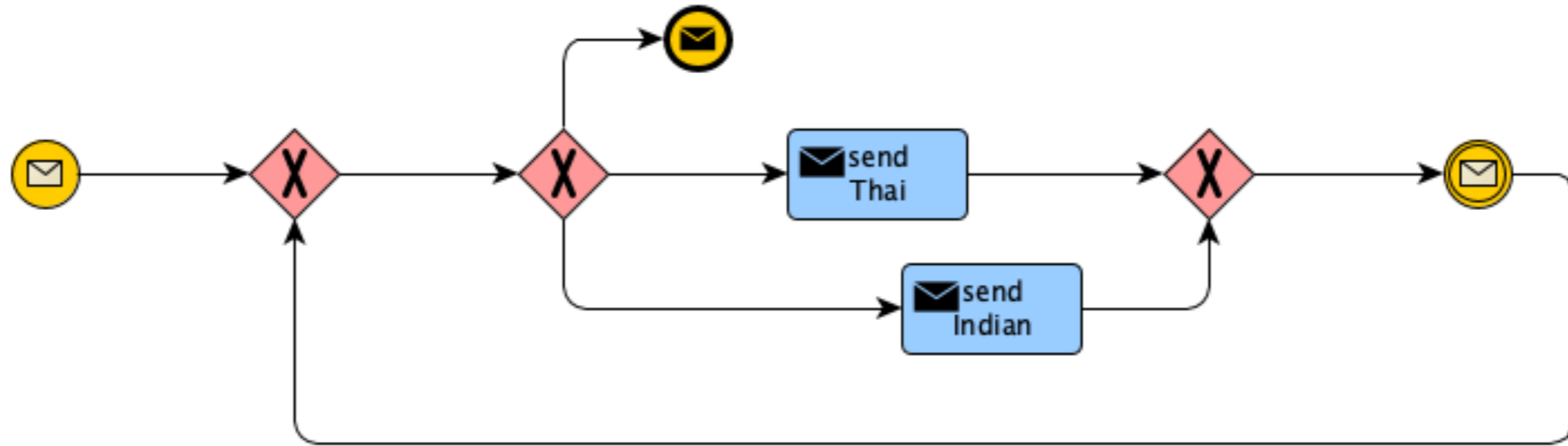

Step 1
sequence flow
message flow

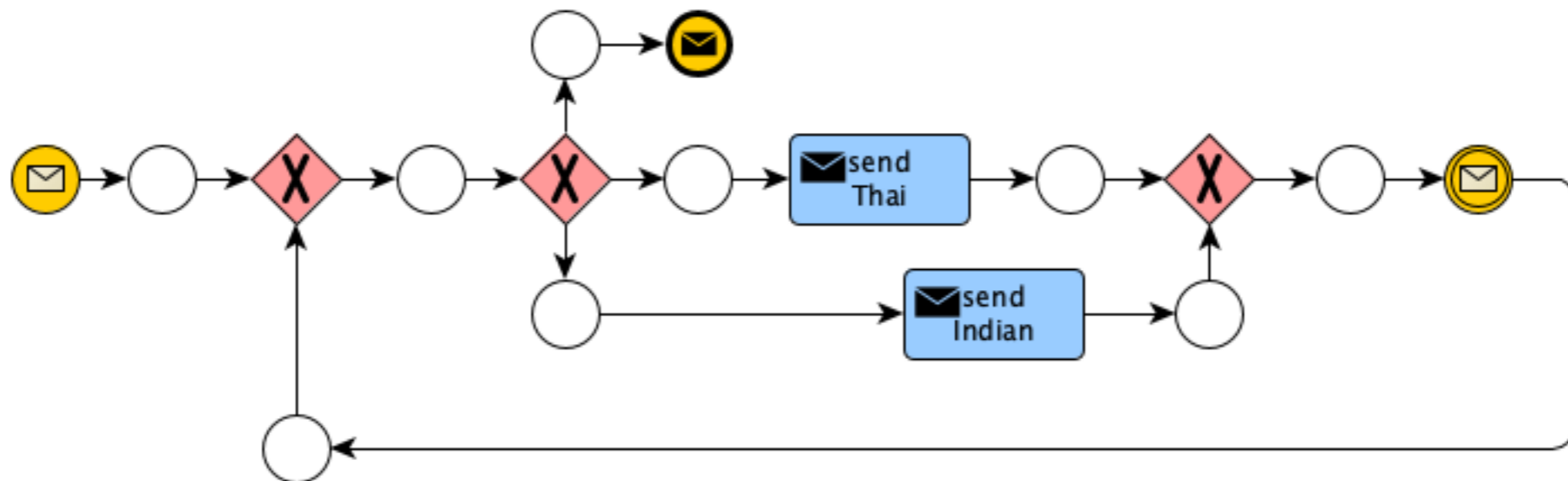

Sushi doomed: step 2

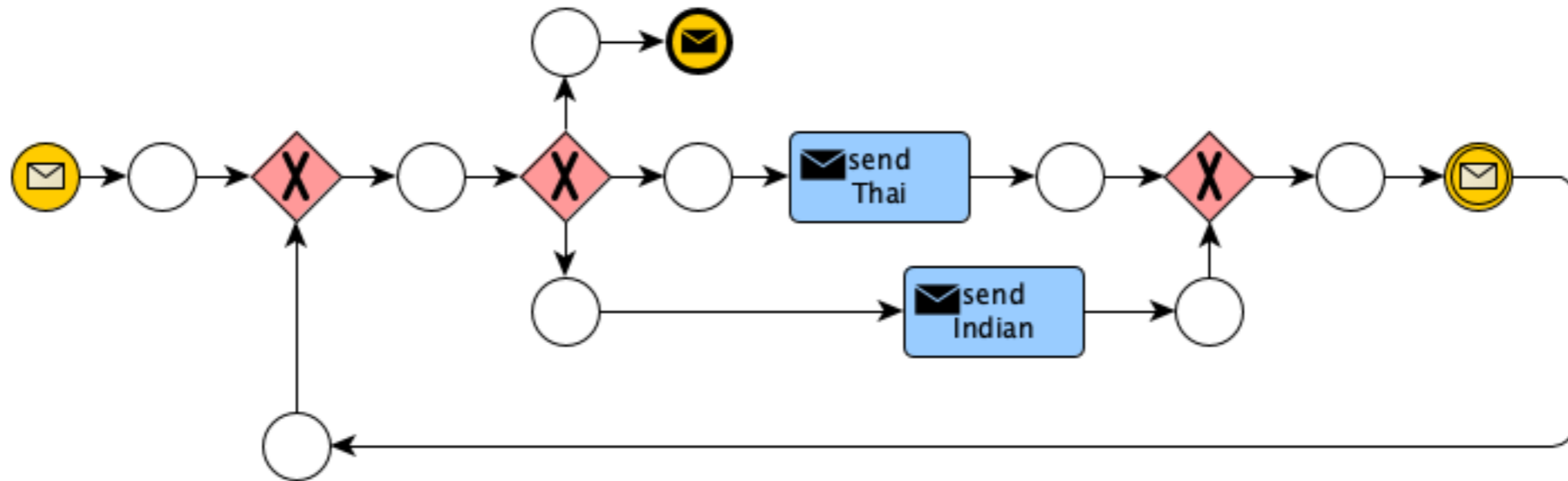

Step 2
flow objects

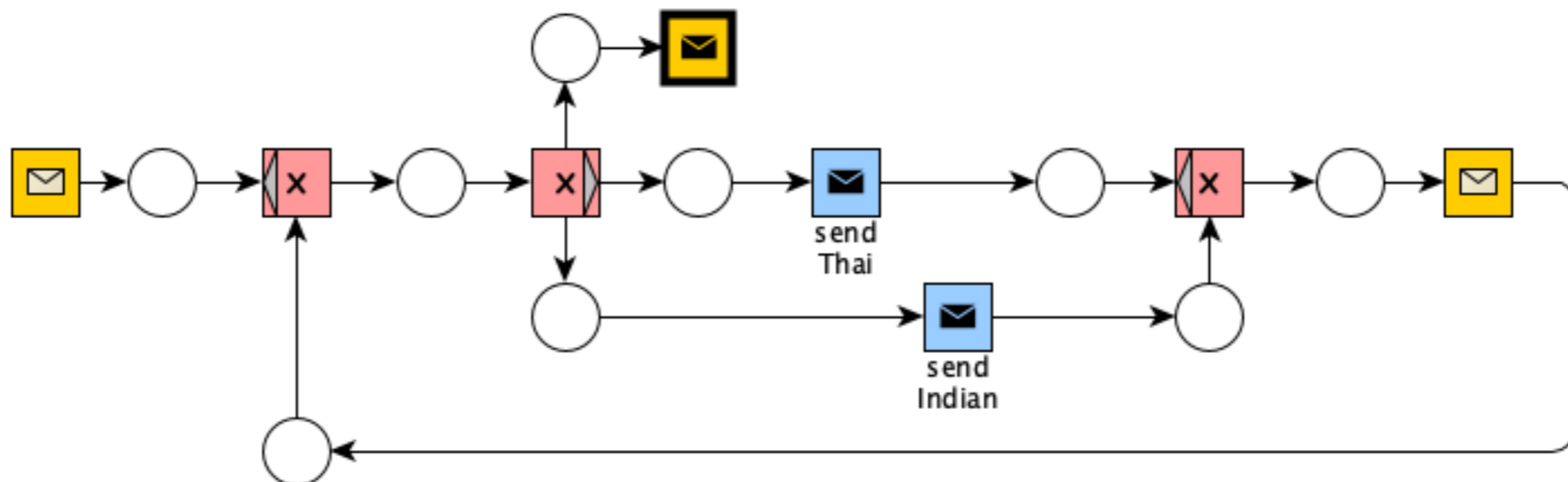

Sushi doomed: (desugar)

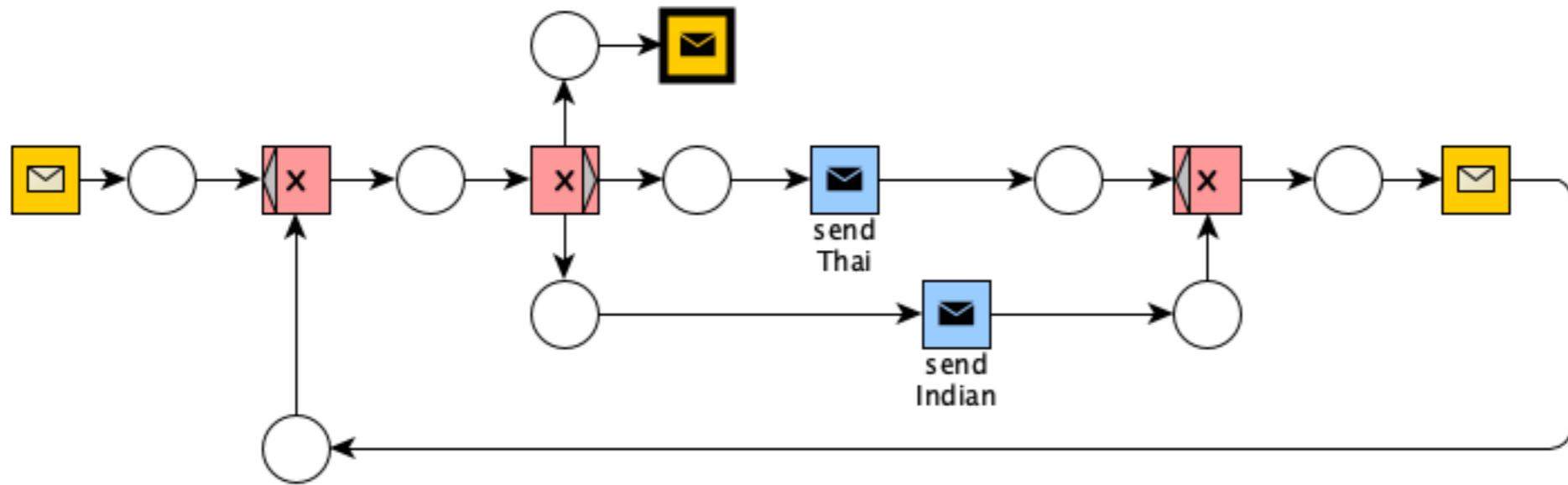

desugar

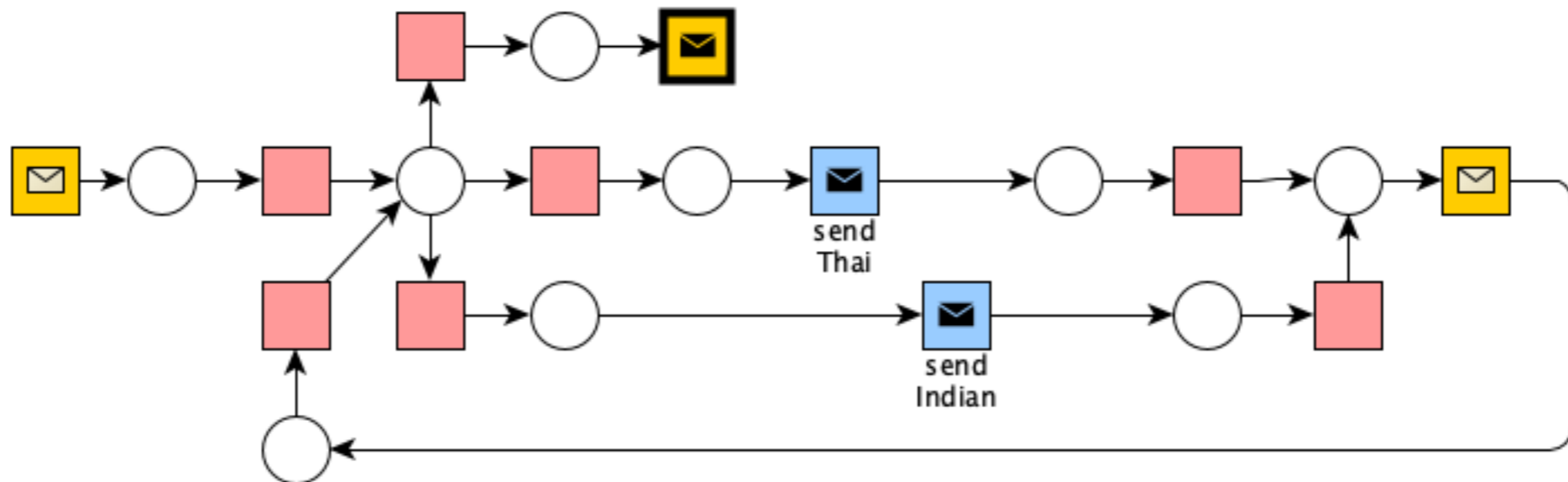

Sushi doomed: step 3

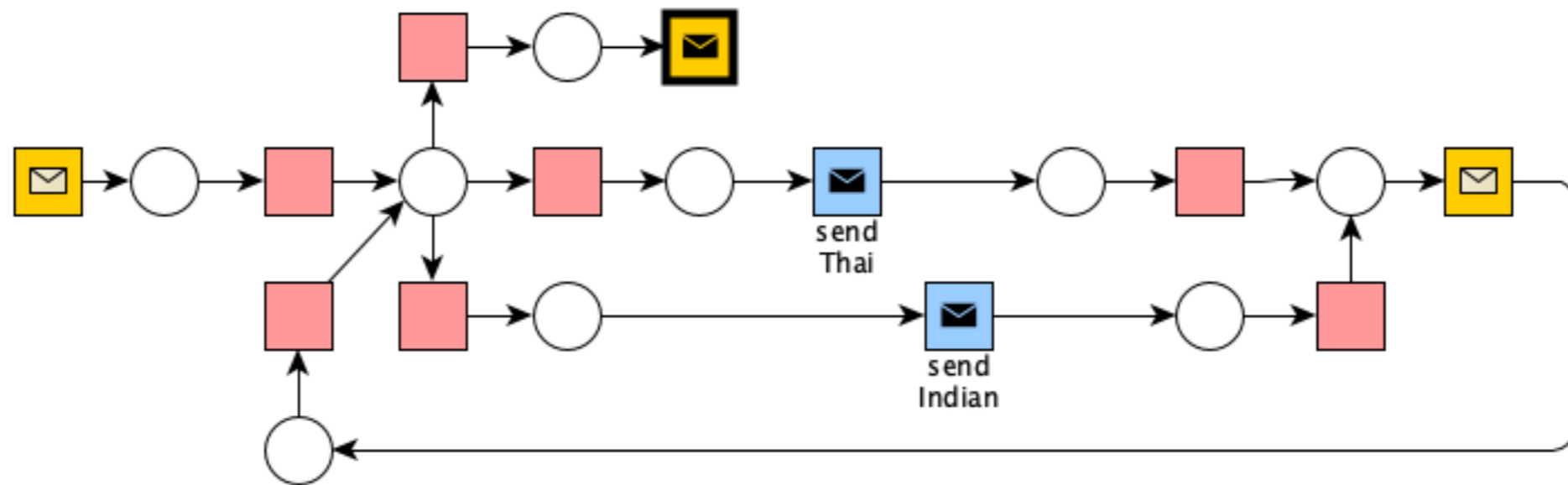

Step 3
enforce
initial place
final place

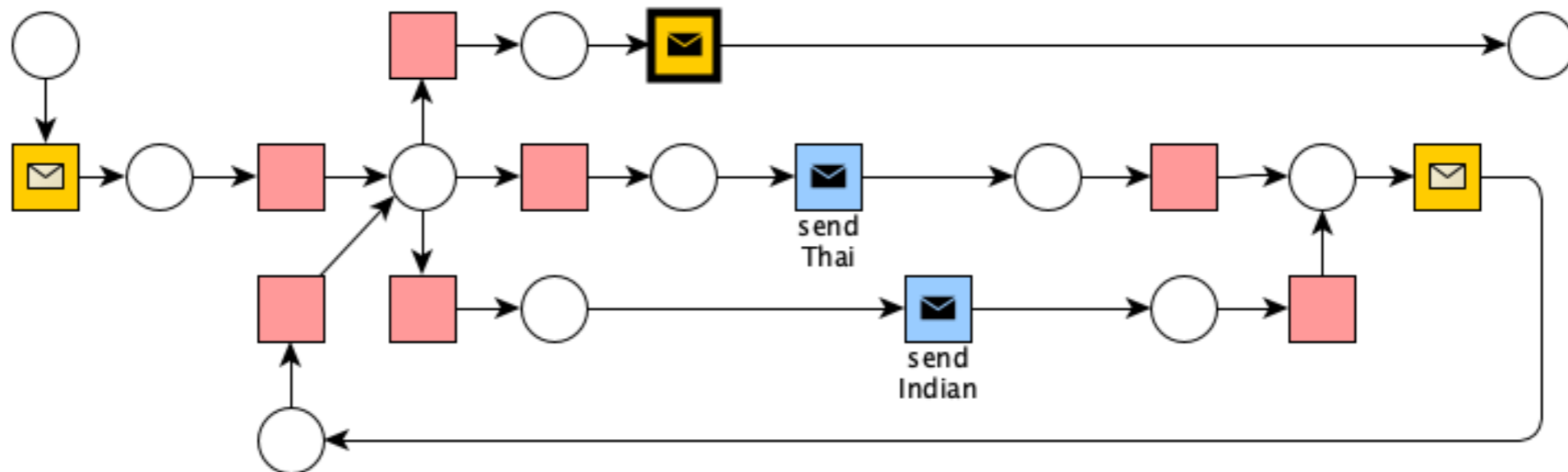

Soundness analysis

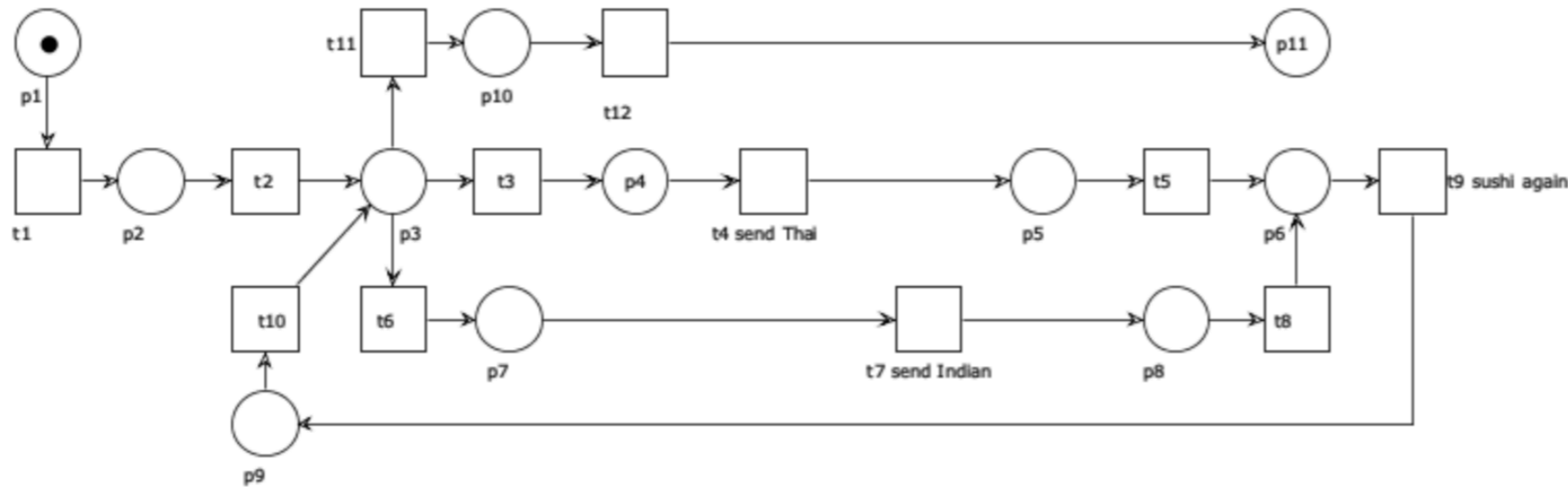

safe & sound
(s-net)

Semantical analysis

Wizard Expert

- Qualitative analysis
 - Structural analysis
 - Net statistics
 - Wrongly used operators: 0
 - Free-choice violations: 0
 - S-Components
 - S-Components: 1
 - Places not covered by S-Comp: 0
 - Wellstructuredness
 - PT-Handles: 0
 - TP-Handles: 0
 - Soundness
 - Workflow net property
 - Initial marking
 - Boundedness
 - Liveness

Sushi system

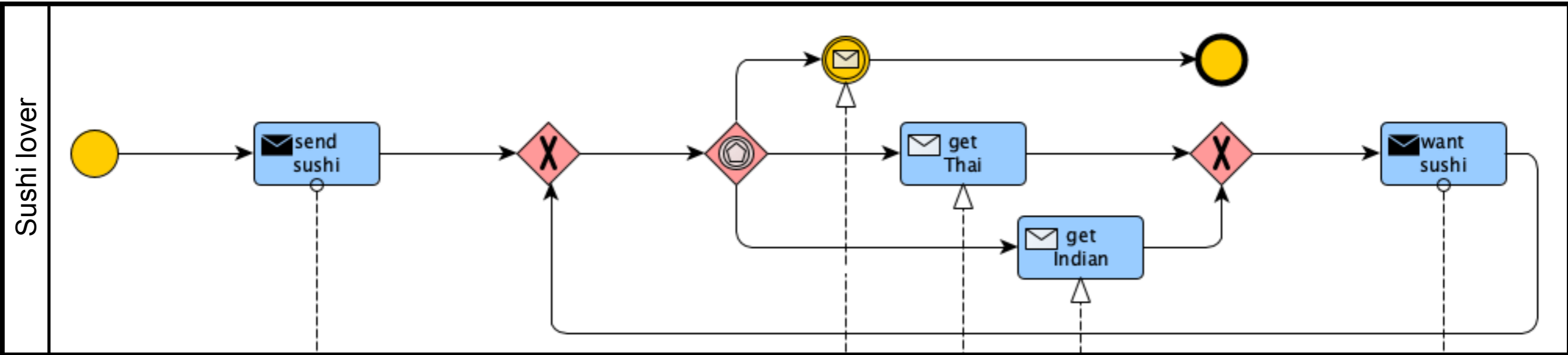

Sound?

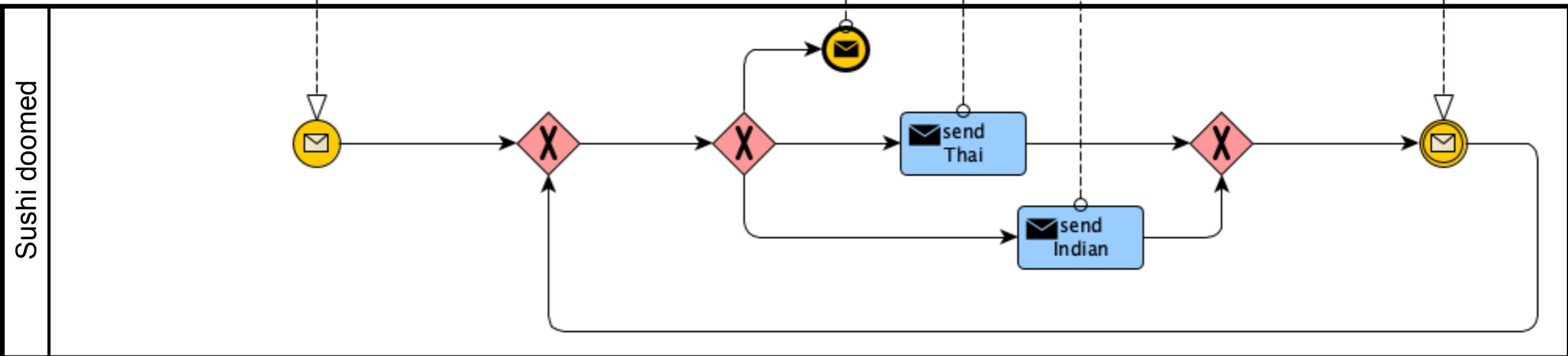

Sushi system: step 1

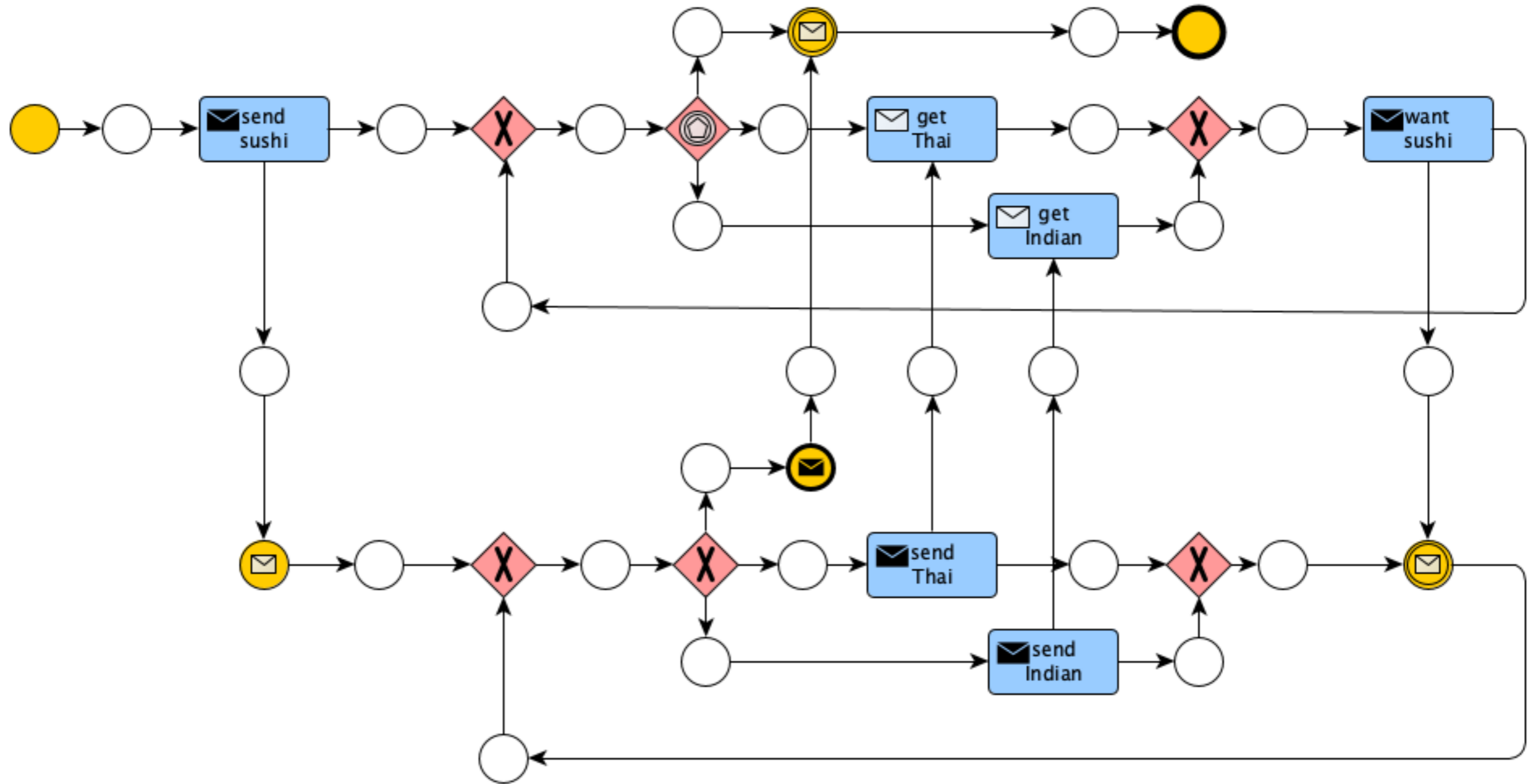

Sushi system: step 1+2+3

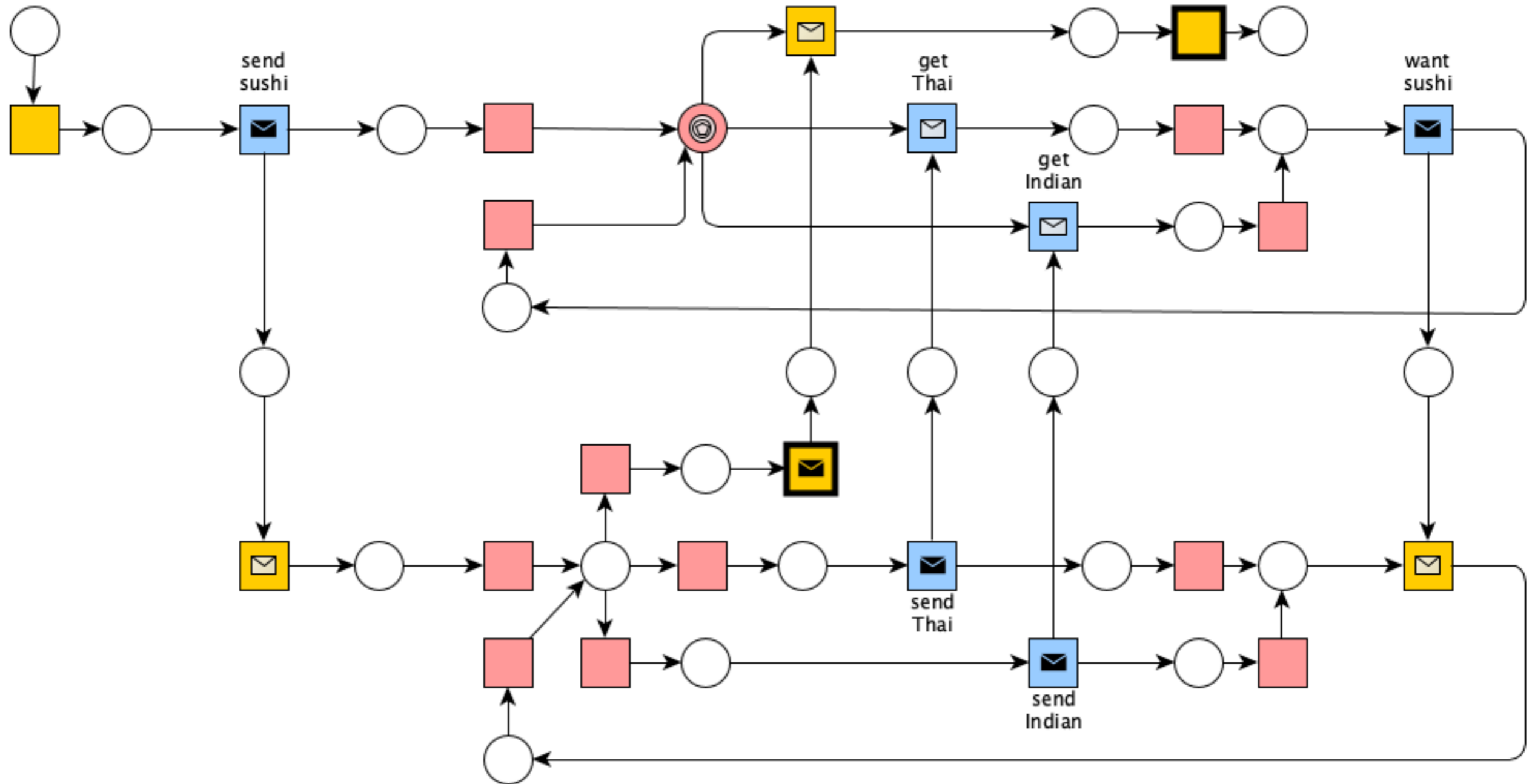

Soundness analysis

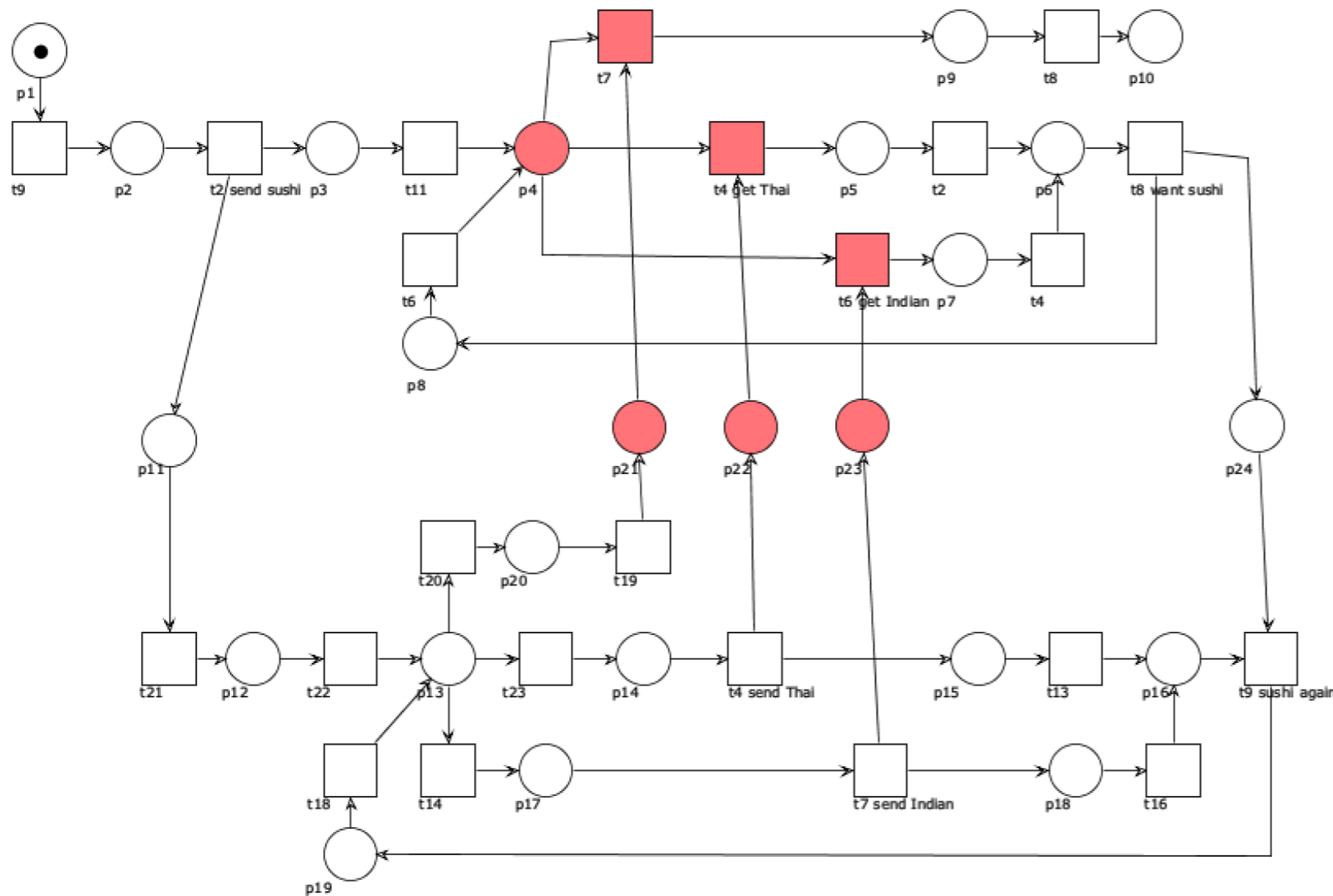

Semantical analysis

Wizard Expert

- Qualitative analysis
 - Structural analysis
 - Net statistics
 - Wrongly used operators: 0
 - Free-choice violations: 1
 - Free-choice violation group 1
 - S-Components
 - Wellstructuredness
 - PT-Handles: 8
 - TP-Handles: 14
- Soundness
 - Workflow net property
 - Initial marking
 - Boundedness
 - Liveness

Sound!

Soundness analysis

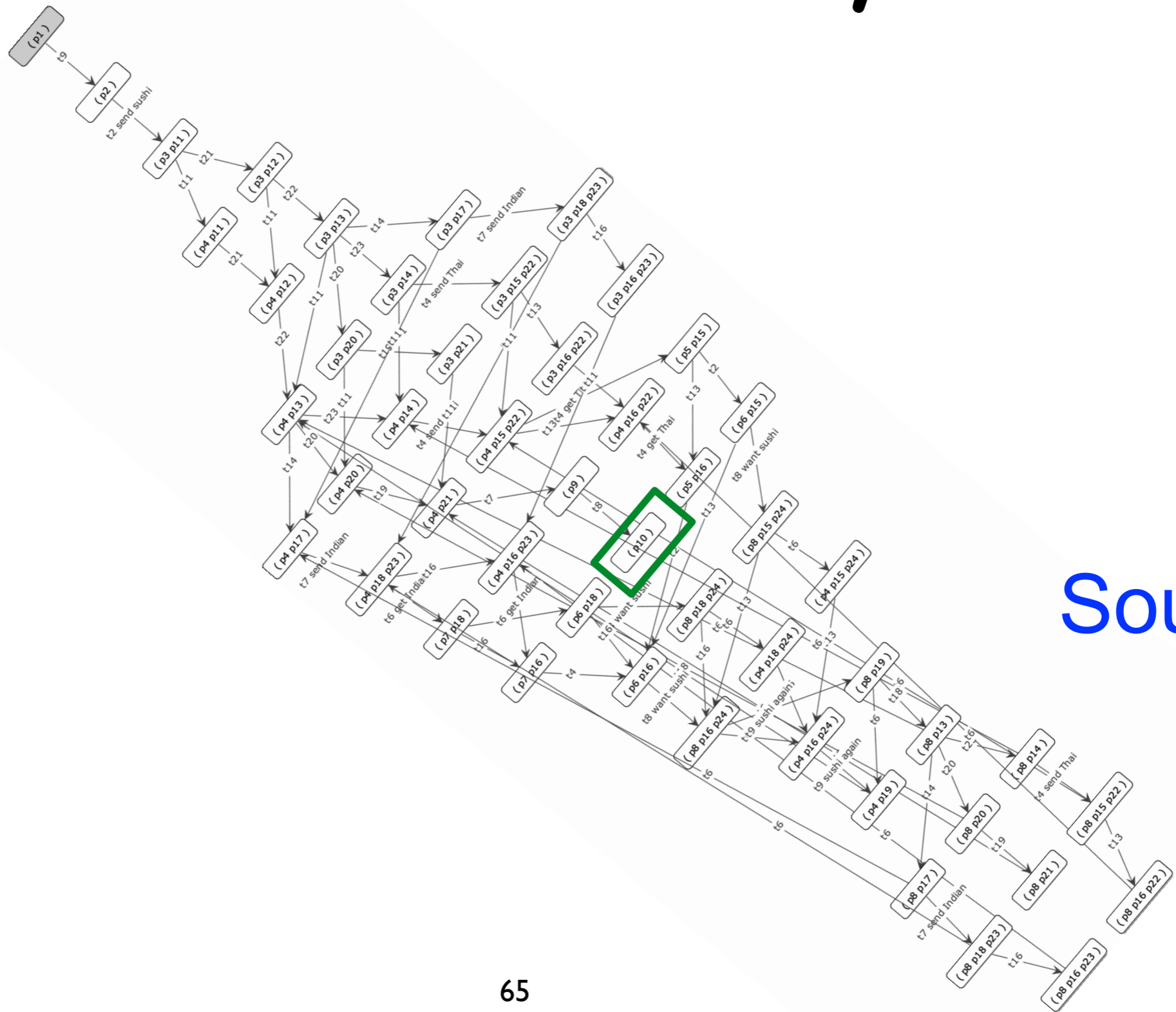

Sound!

Example:
Buyer - Reseller

Buyer 3 and Reseller 2

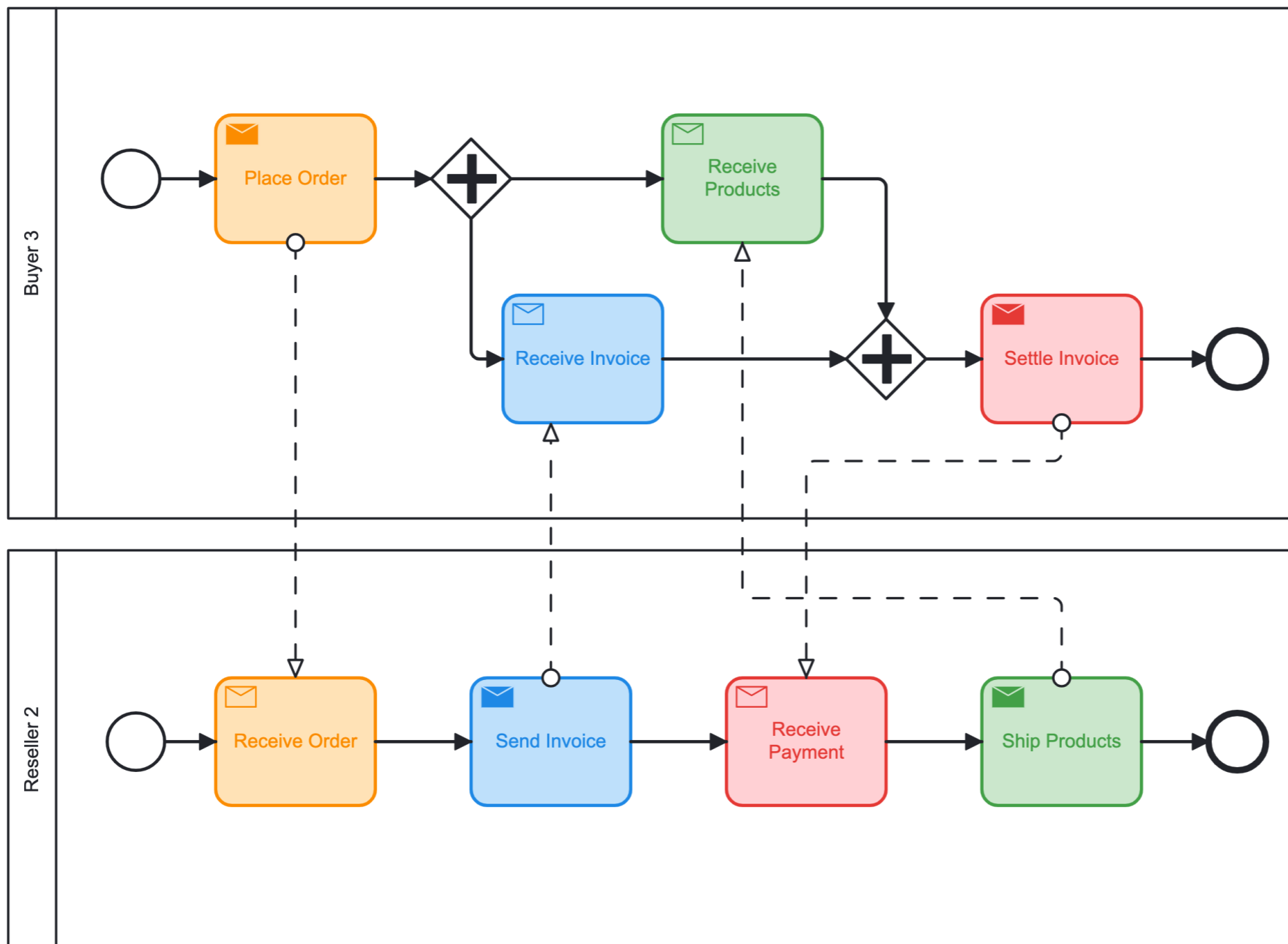

Sound?

Buyer 3 sound?

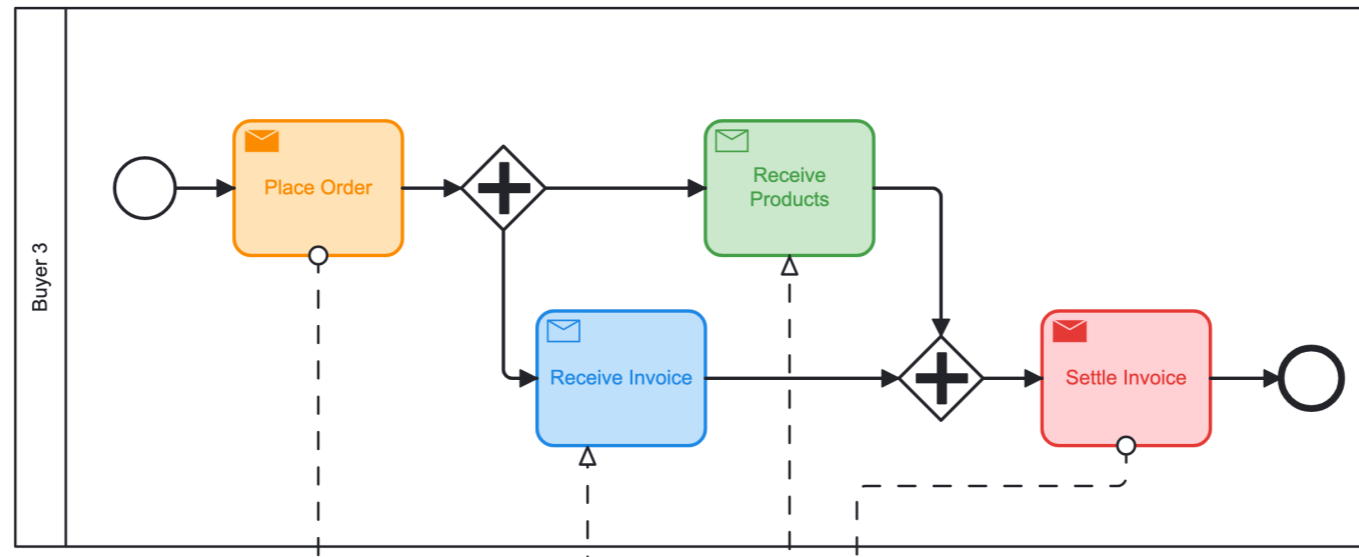

Step 1 + 2 + 3

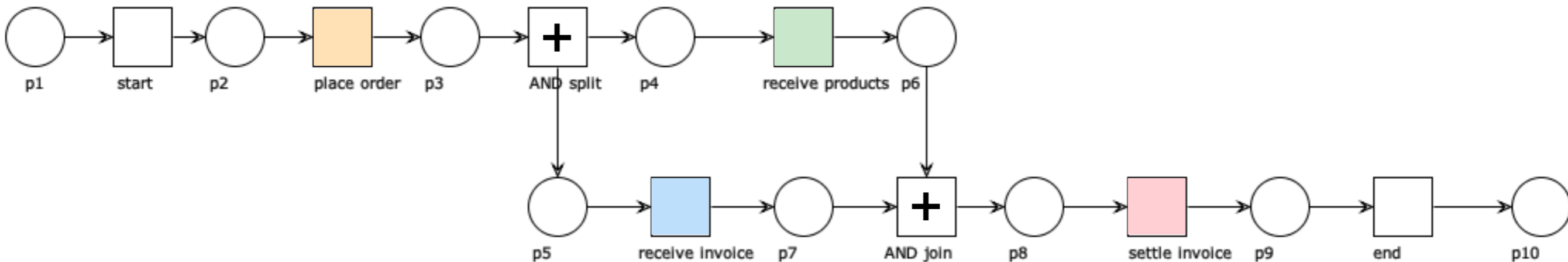

Buyer 3 soundness analysis

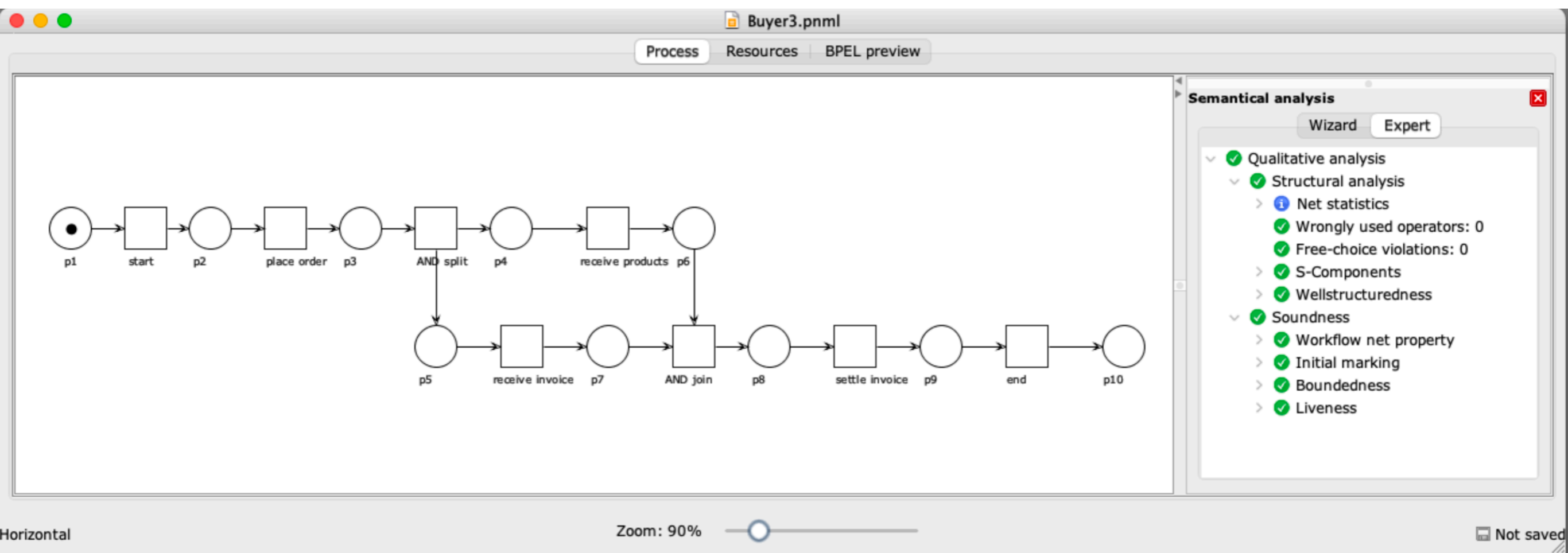

Safe and sound!

Reseller 2 sound?

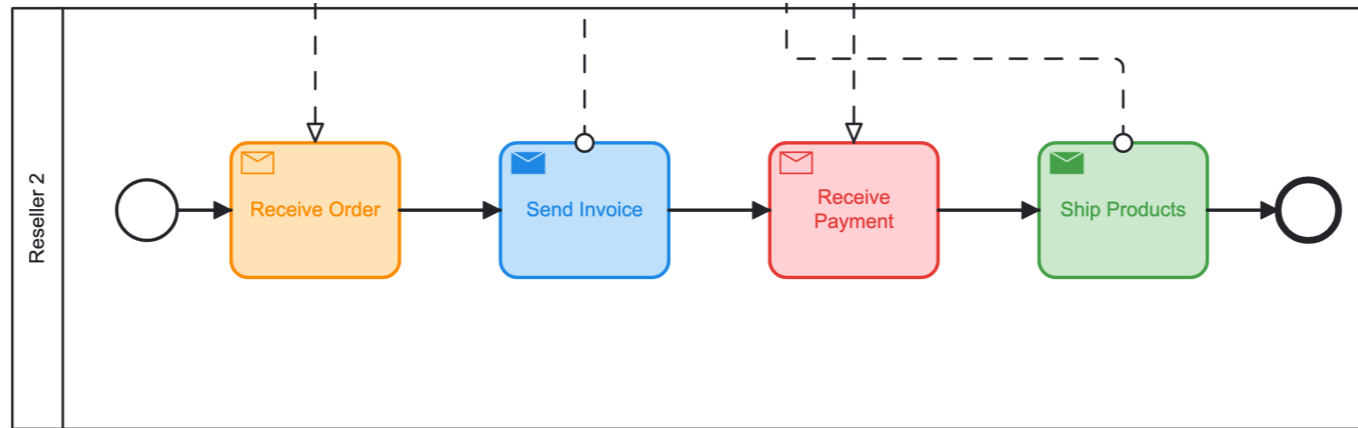

↓ Step 1 + 2 + 3



Reseller 2 soundness analysis

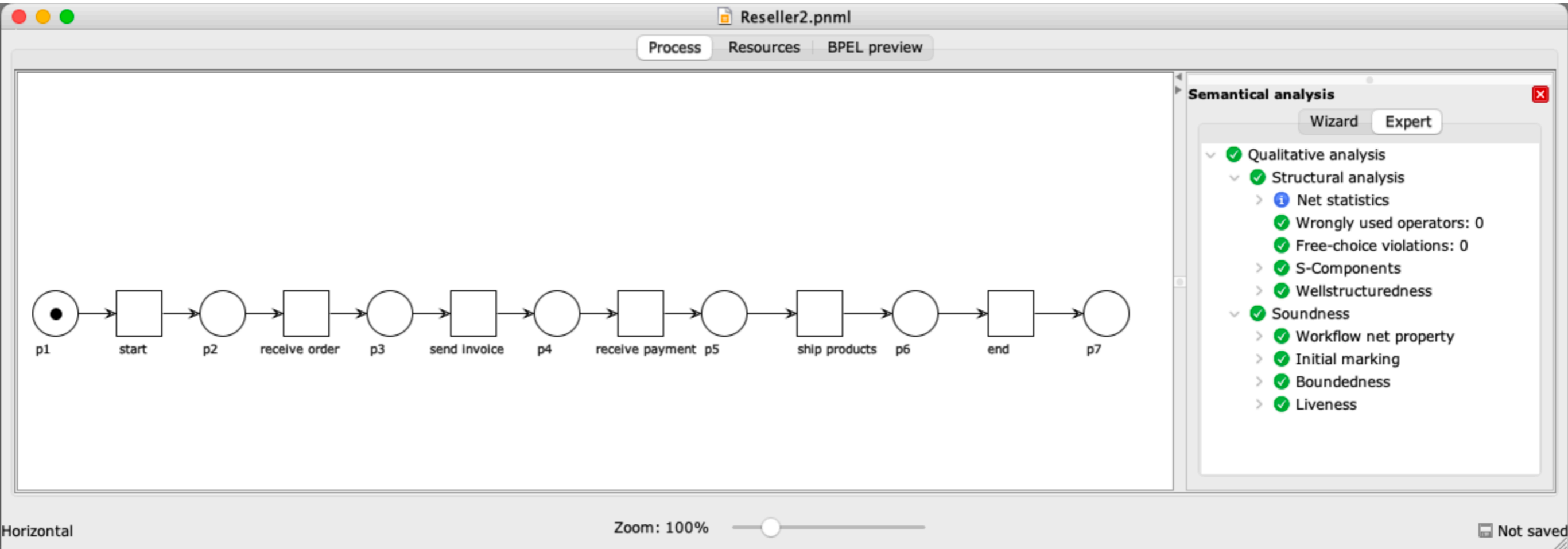

Safe and sound!

Buyer 3 + Reseller 2: sound?

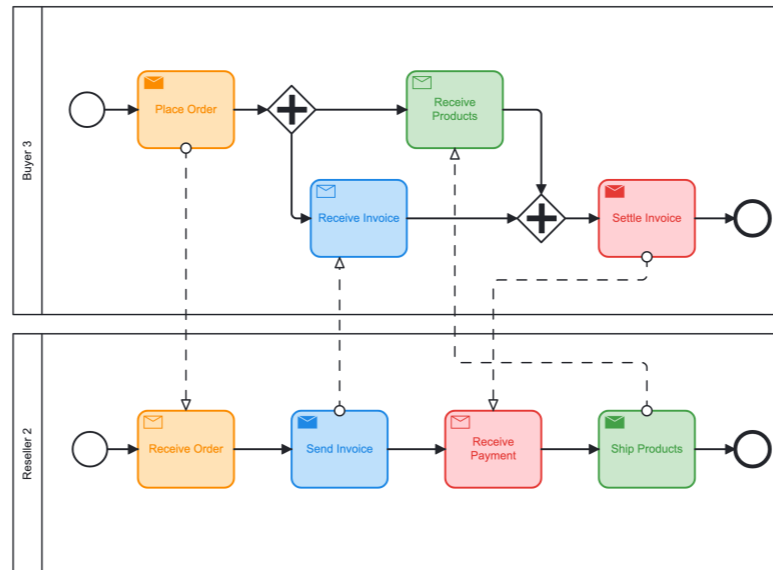

Step 1 + 2 + 3

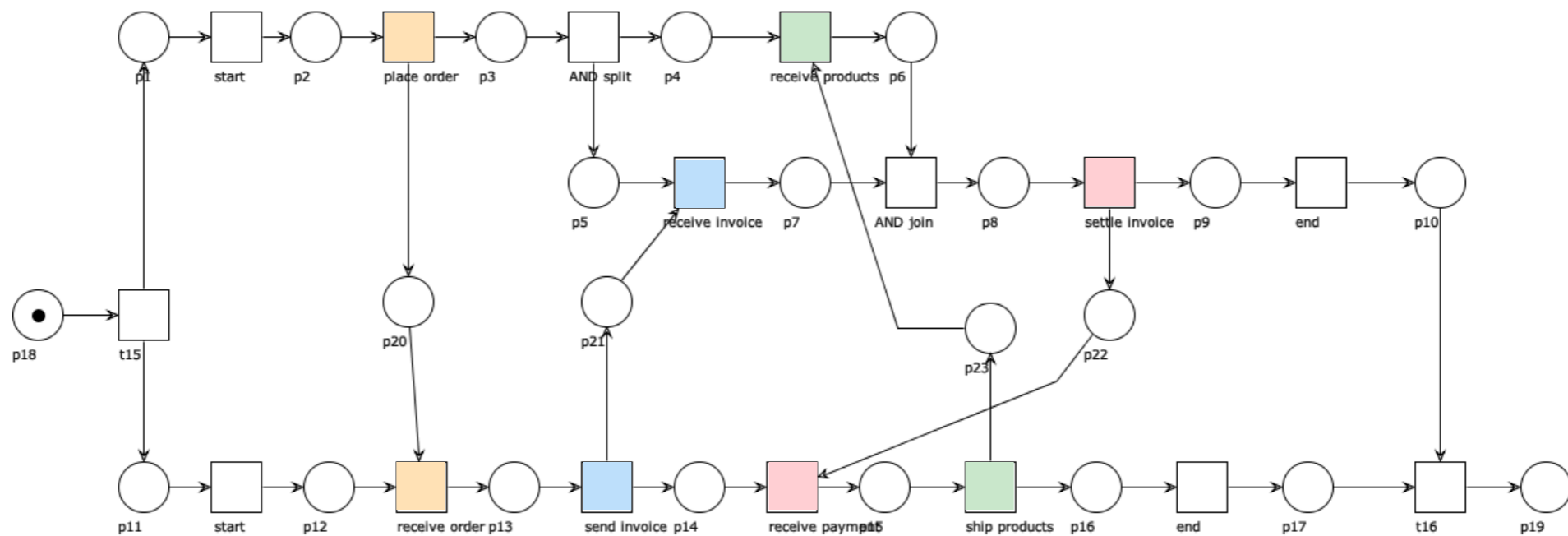

Buyer 3 + Reseller 2: analysis

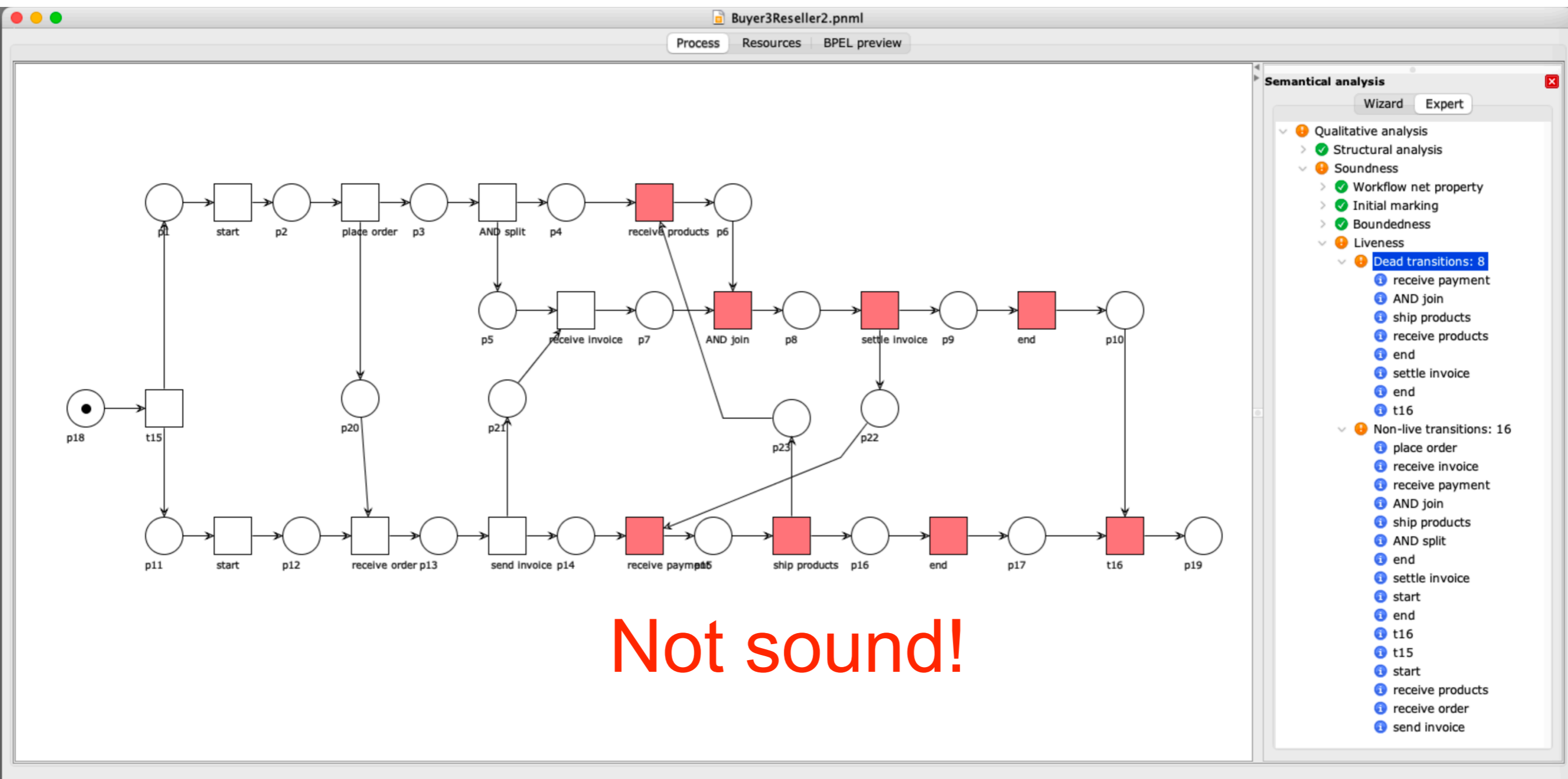

Not sound!

Buyer 3 + Reseller 2: analysis

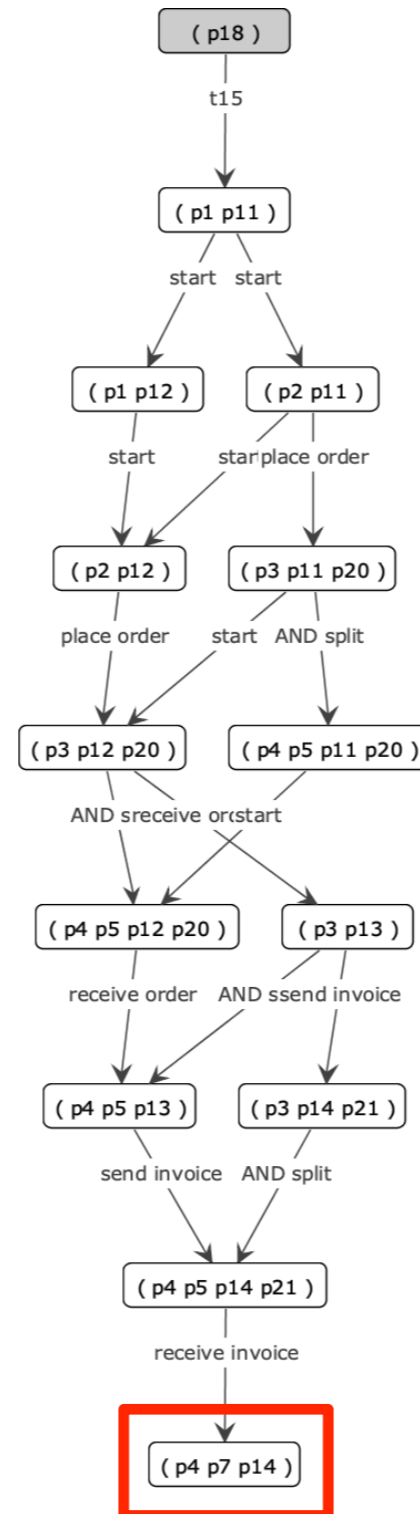

Not sound!

Step 0: preprocessing BPMN diagrams

Overview

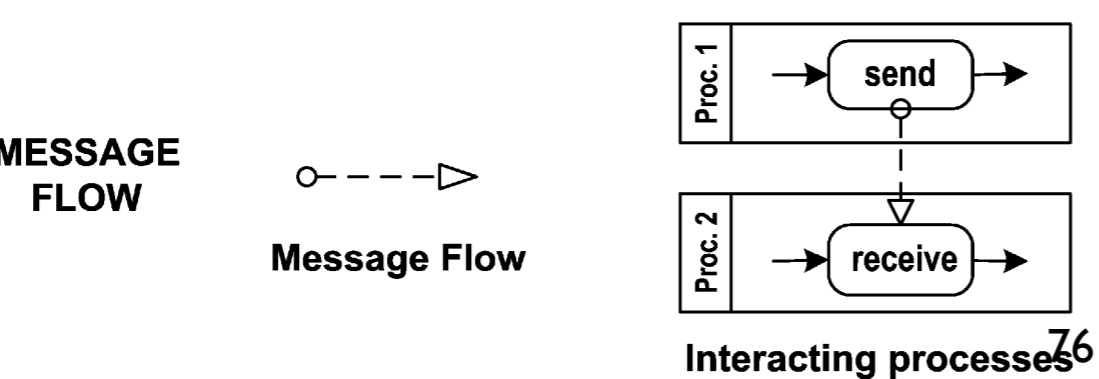
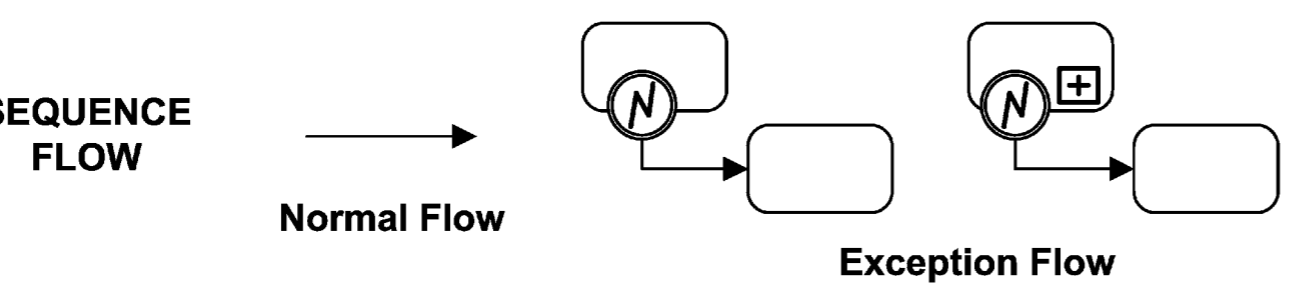
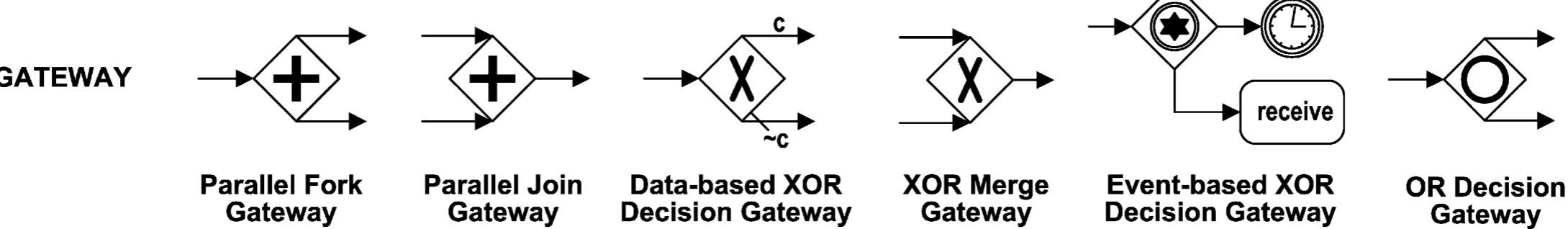
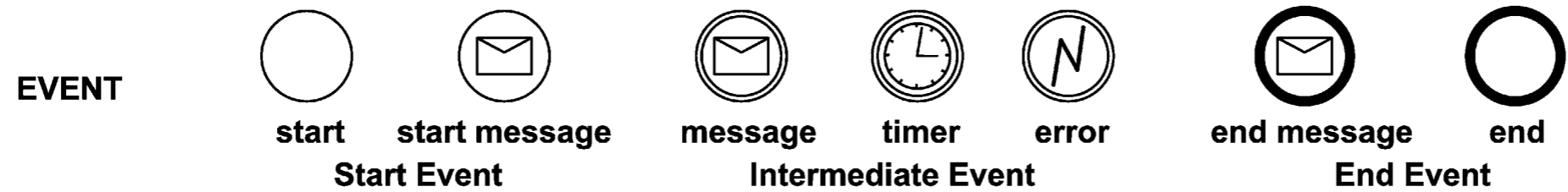

- [Note]:
1. Apart from intermediate error events, intermediate message or timer events may also be the source of exception flows.
 2. A message flow may link task to task, end event to task, task to start event, and end event to start event.

Activity looping

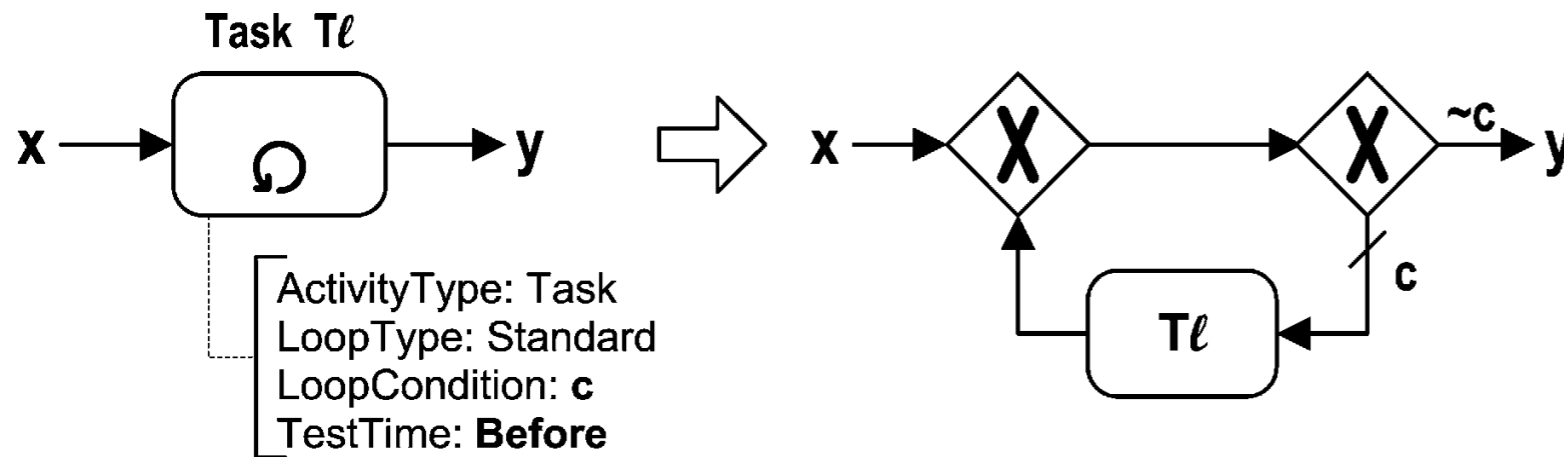

(a) “while-do” loop

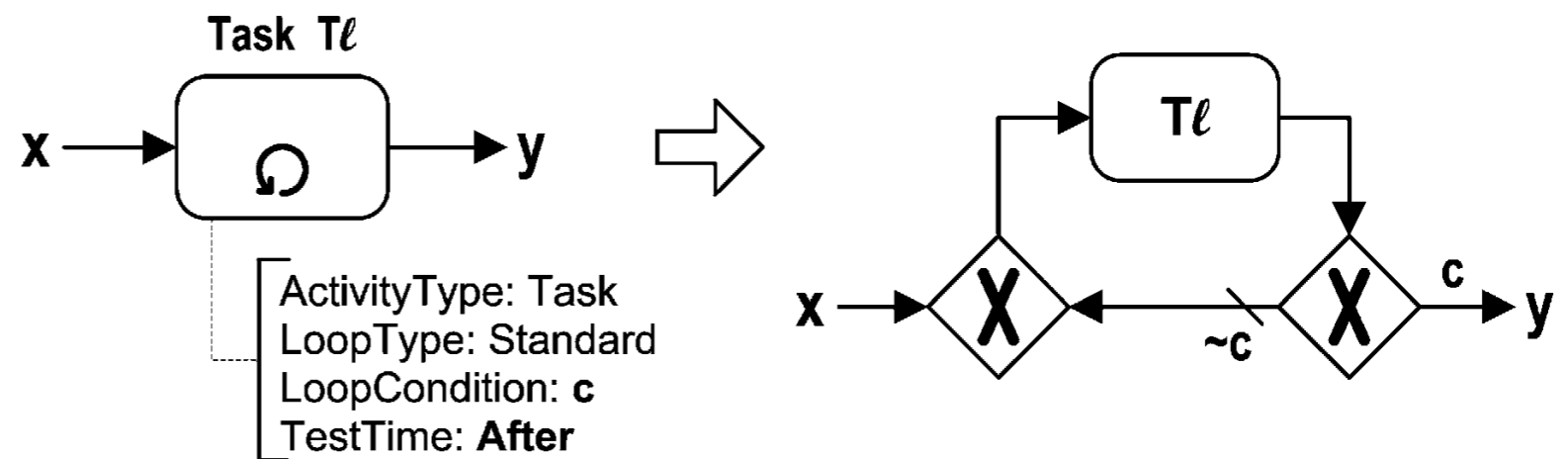

(b) “do-until” loop

Multiple instances (design-time bounded)

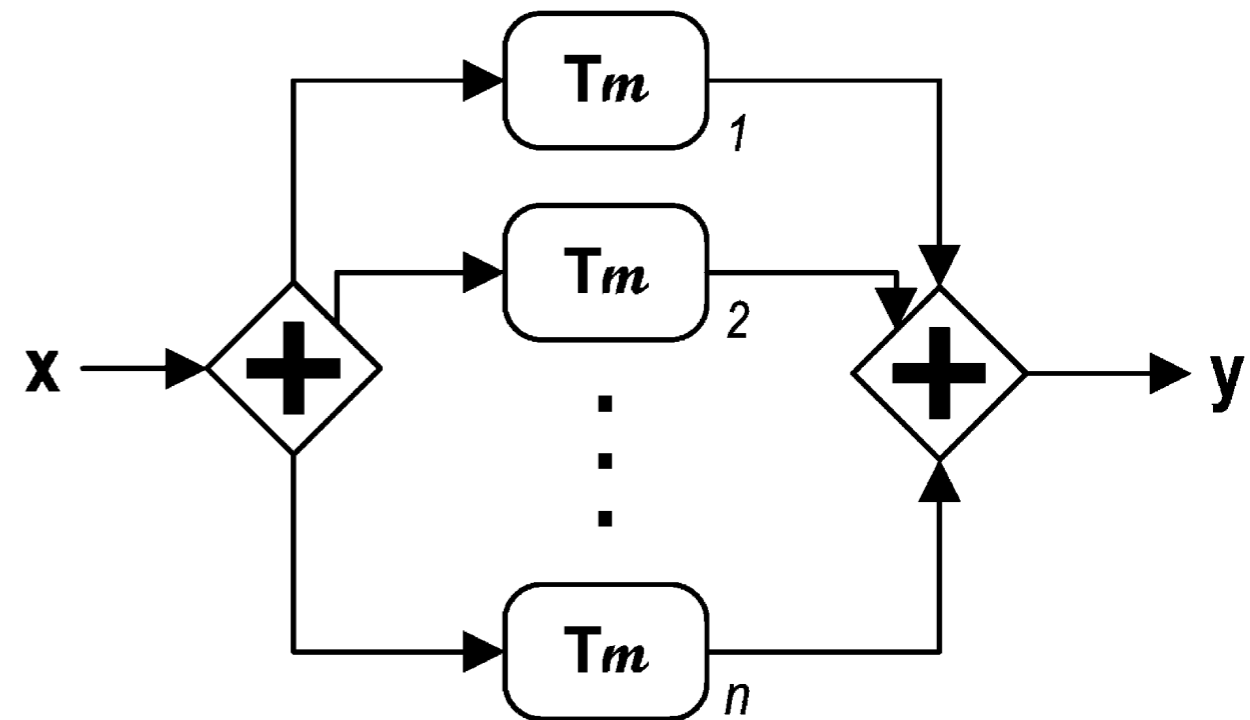
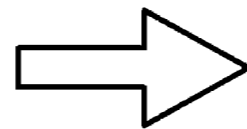
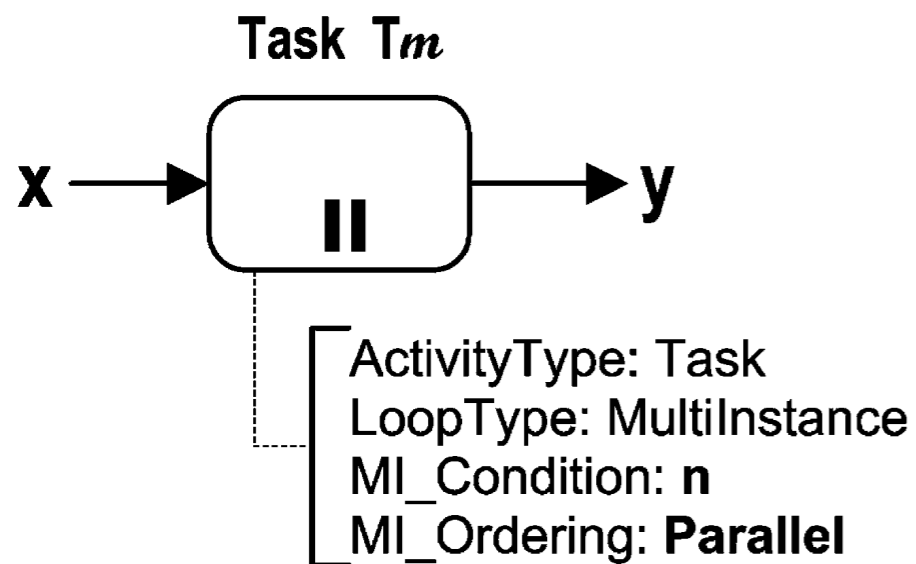

Sub-processes

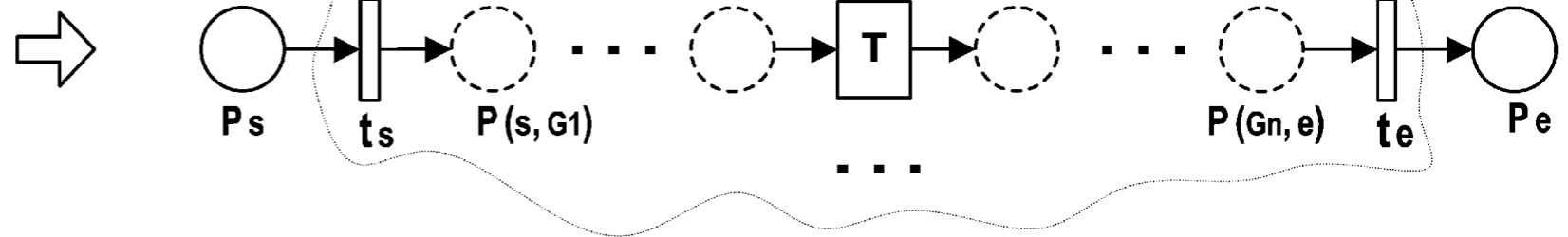
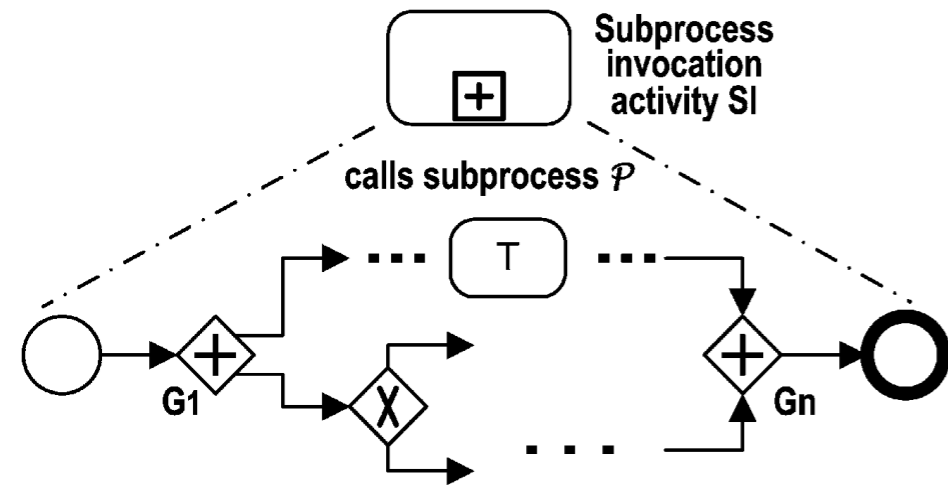
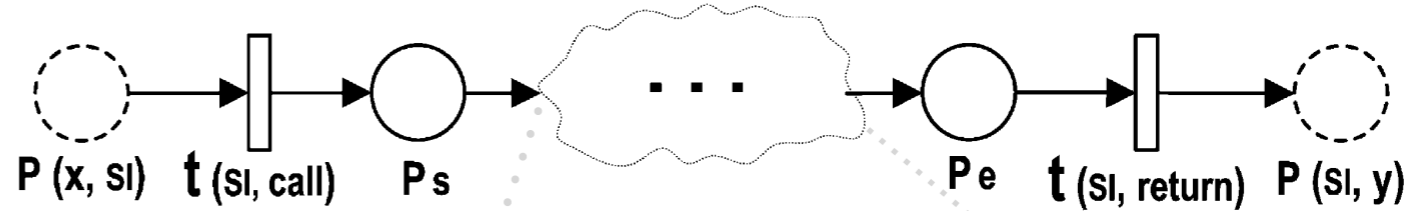
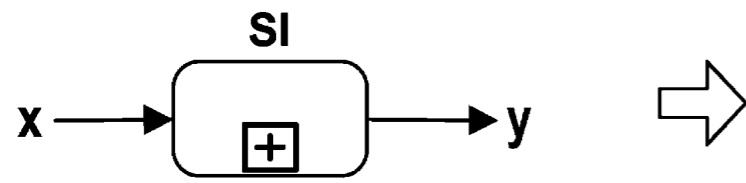

Exception handling: single task

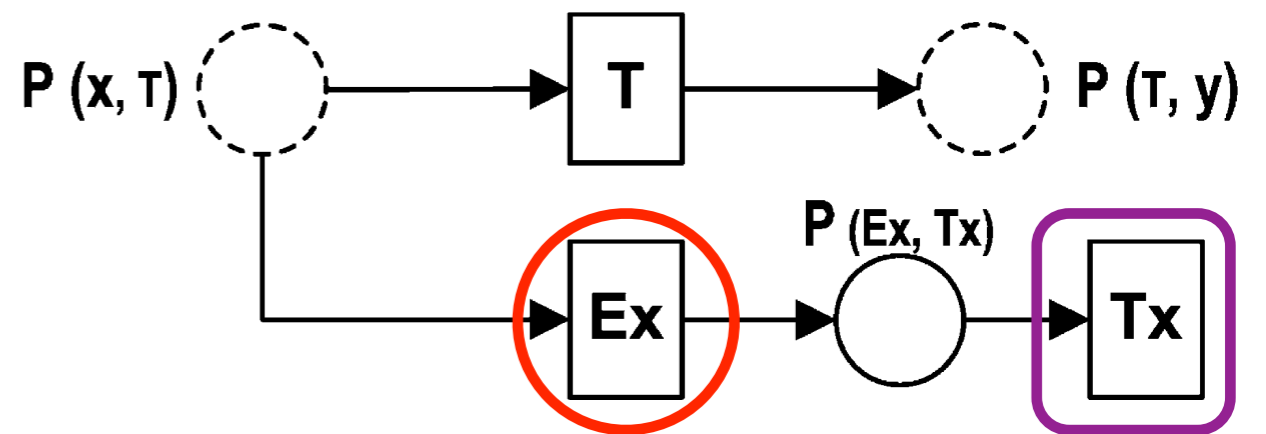
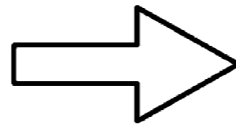
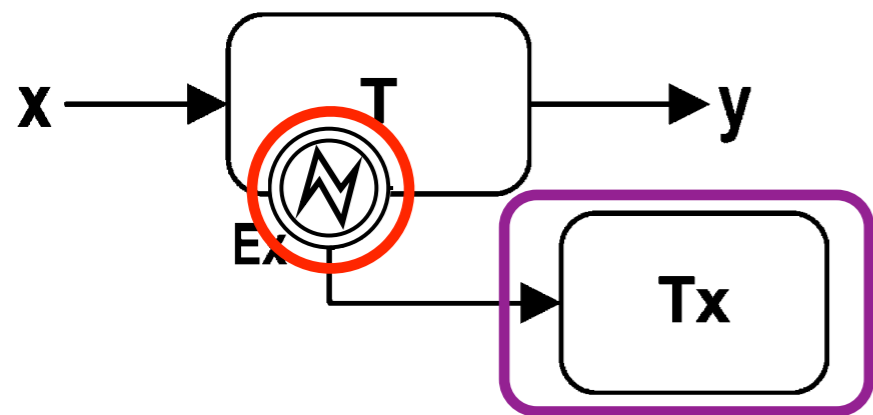

Exception handling: sub-processes

accounts for
separate execution
of multiple instances

